

S7D-S8D ENGINE MODELS

Important Notice

The manuals contained in this computer file are reproductions from the "Wisconsin Engine" counter catalog, part number "S236". This manual was last produced in the mid 1980's.

As with any printed data, the information contained in these manuals may not be the most up-to-date available. It is provided as a convenience to our customers and all information should be verified before making repairs to an engine or component.

SERVICE FACILITIES

WISCONSIN MOTORS, L.L.C. Distributors and Service Centers, located throughout the U.S. and foreign countries, have been carefully selected to insure complete and efficient repair and inspection services to owners of **WISCONSIN MOTORS** Engines. These service centers, equipped and staffed for complete engine repair, also stock engines parts to facilitate immediate delivery for the complete line of **WISCONSIN MOTORS** Engines.

Order parts from the **WISCONSIN MOTORS, L.L.C.** Distributor or Service Center in your locality. Refer to the Yellow Pages of the Telephone Directory under **ENGINES**, or visit our website, www.wisconsinmotors.com to locate a distributor in your area. You can also call Wisconsin Motors toll free, 800-932-2858.

The **MODEL**, **SPECIFICATION** and **SERIAL NUMBER** of your engine must be given when ordering parts. The **MODEL**, **SPECIFICATION** and **SERIAL NUMBER** are on the engine nameplate.



**Wisconsin
Motors, LLC**

Sales Office

2020 Fletcher Creek Drive - Memphis, TN 38133

Phone (901) 371-0353 Toll Free 800-932-2858

www.wisconsinmotors.com

PARTS FOR ENGINE MODELS S-7D AND S-8D

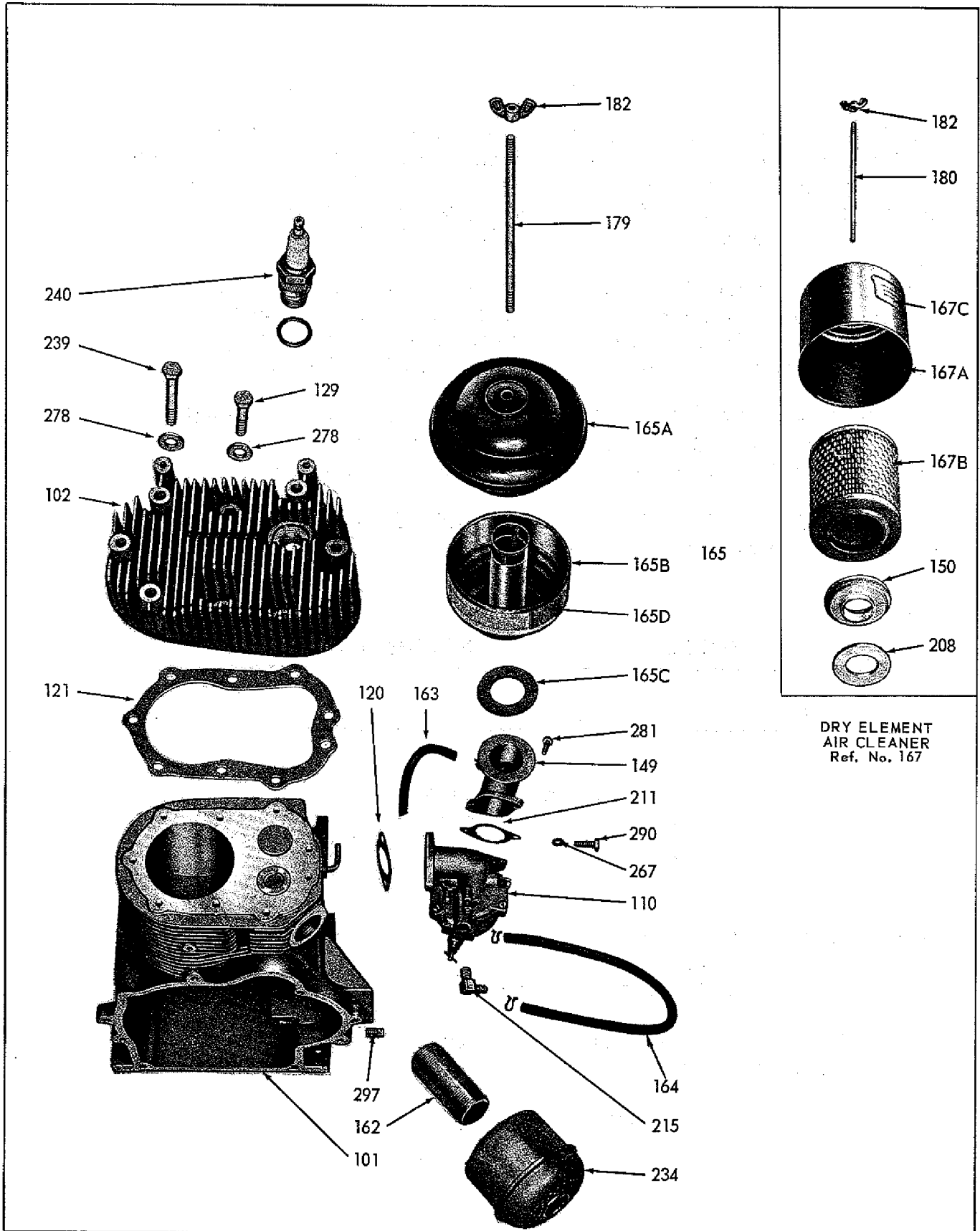

DRY ELEMENT
AIR CLEANER
Ref. No. 167

CRANKCASE, CYLINDER HEAD, CARBURETOR and AIR CLEANER GROUP

Parts are identified by reference number. See parts list for correct part number.

285313C-1

PARTS FOR ENGINE MODELS S-7D AND S-8D

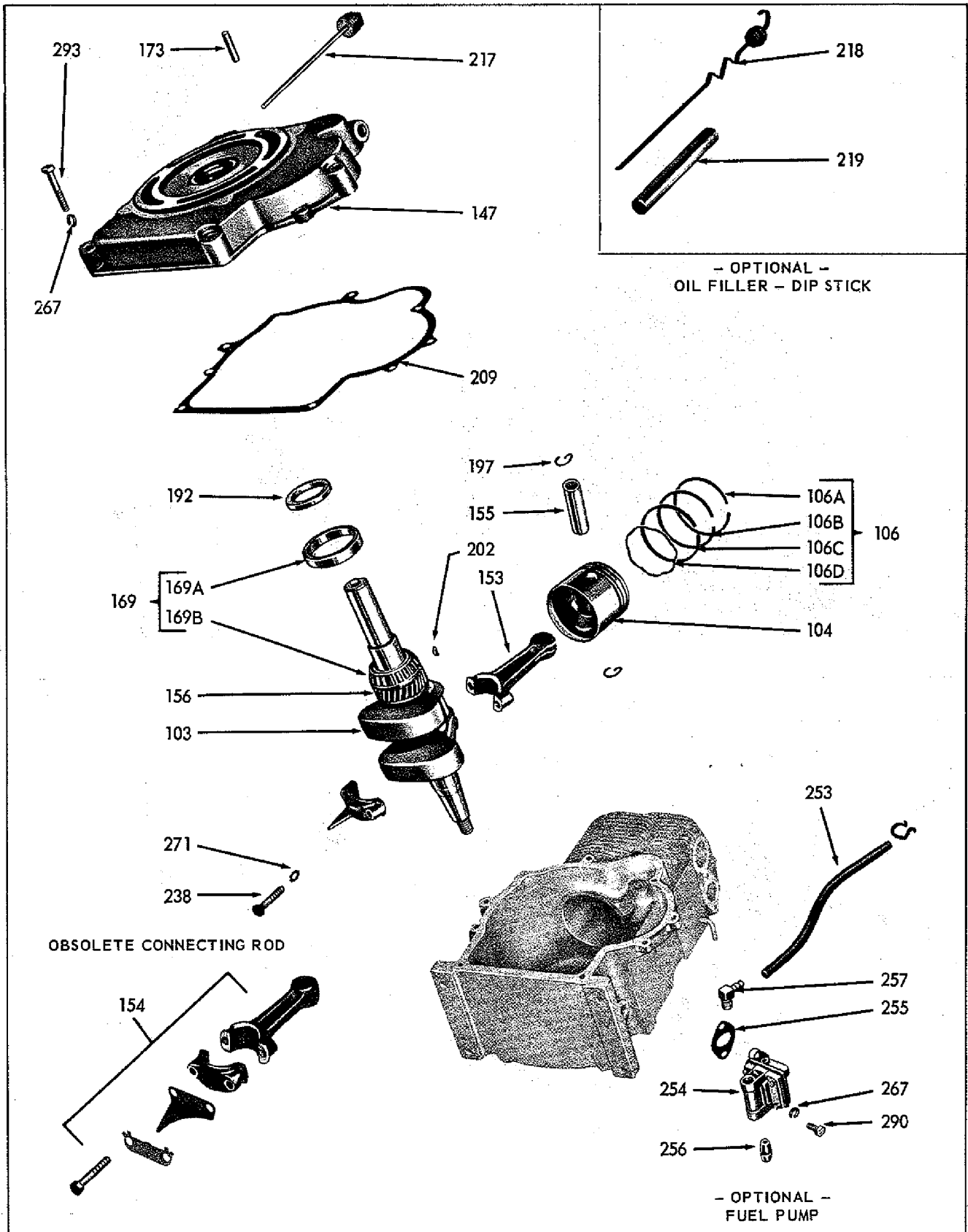

GEAR COVER, CRANKSHAFT, PISTON, CONNECTING ROD and FUEL PUMP GROUP

Parts are identified by reference number. See parts list for correct part number.

303972C-A

PARTS FOR ENGINE MODELS S-7D AND S-8D

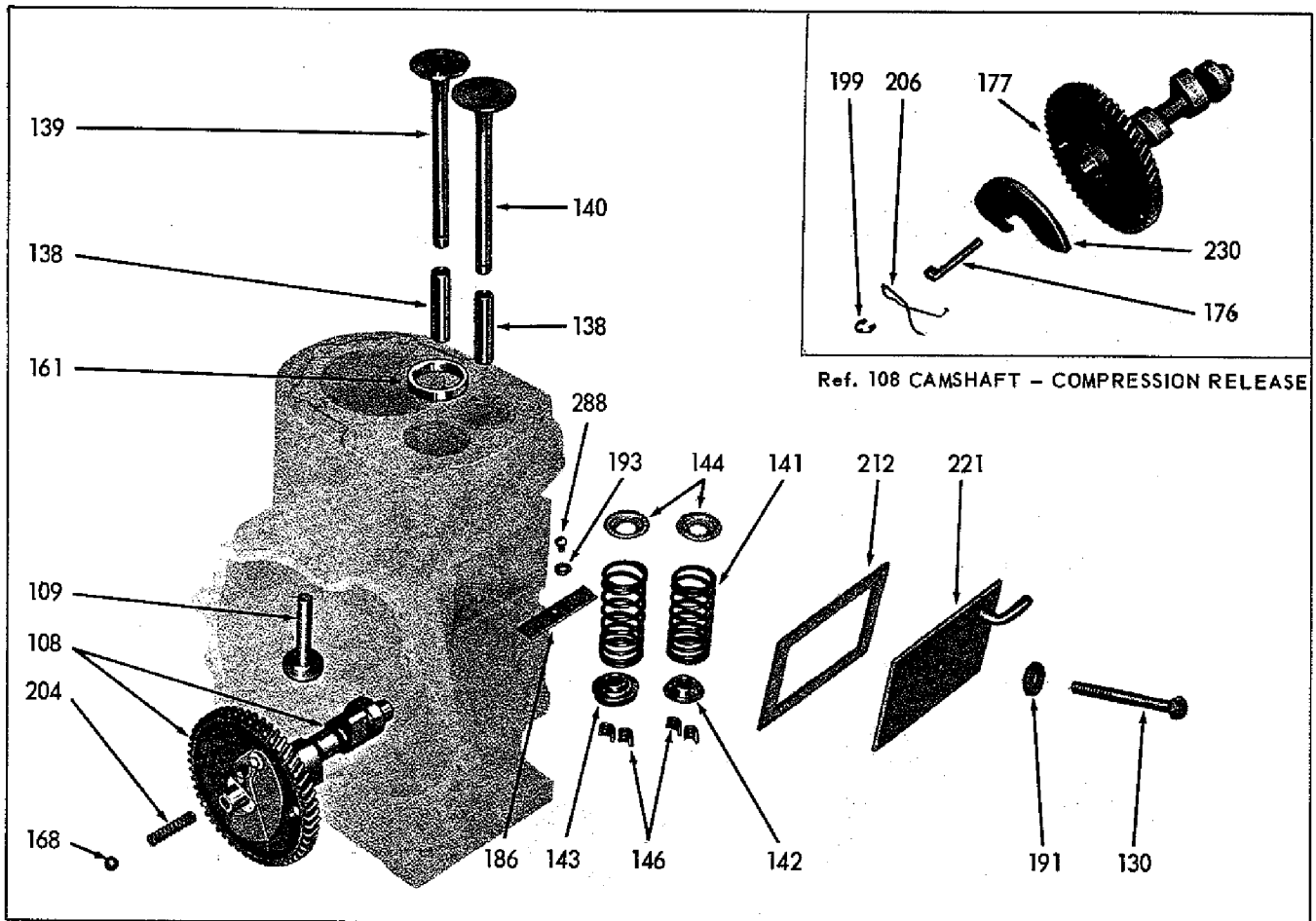

VALVES and CAMSHAFT GROUP

285307C-A

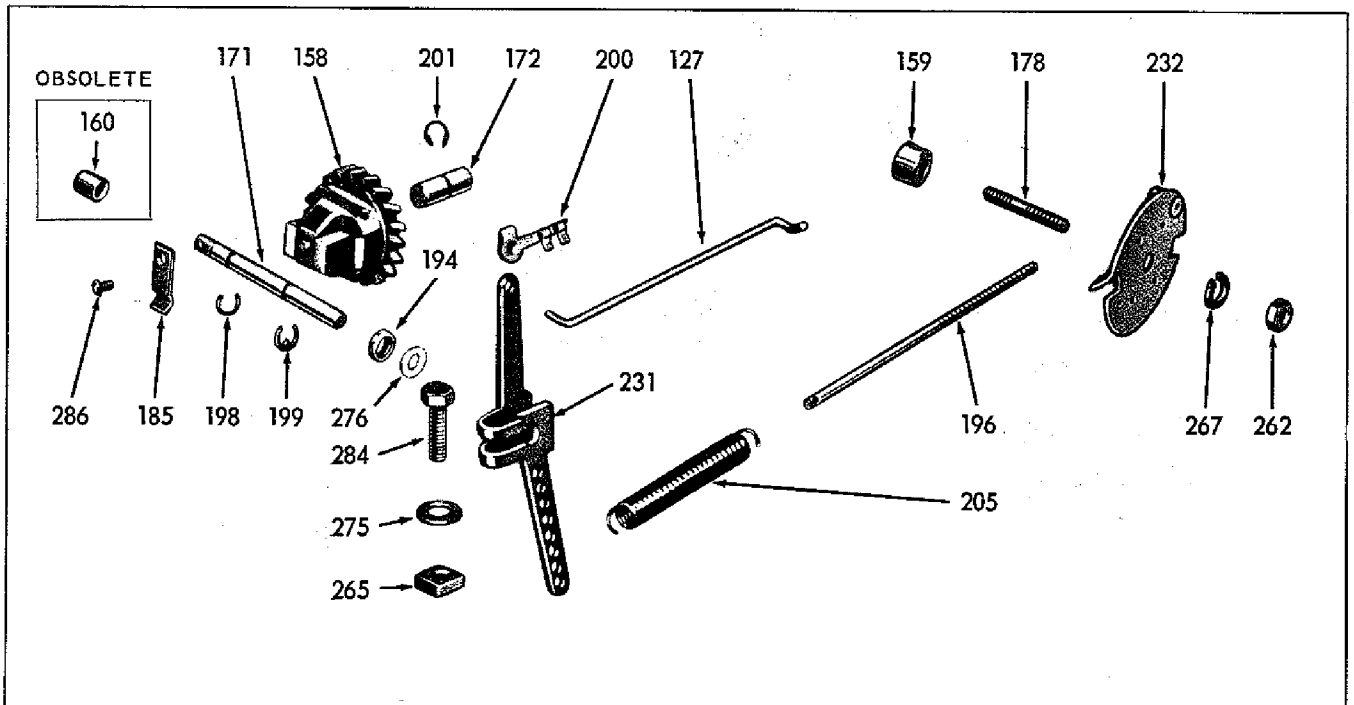

Ref. No. 126, GOVERNOR ASSEMBLY

285314C-1

Parts are identified by reference number. See parts list for correct part number.

PARTS FOR ENGINE MODELS S-7D AND S-8D

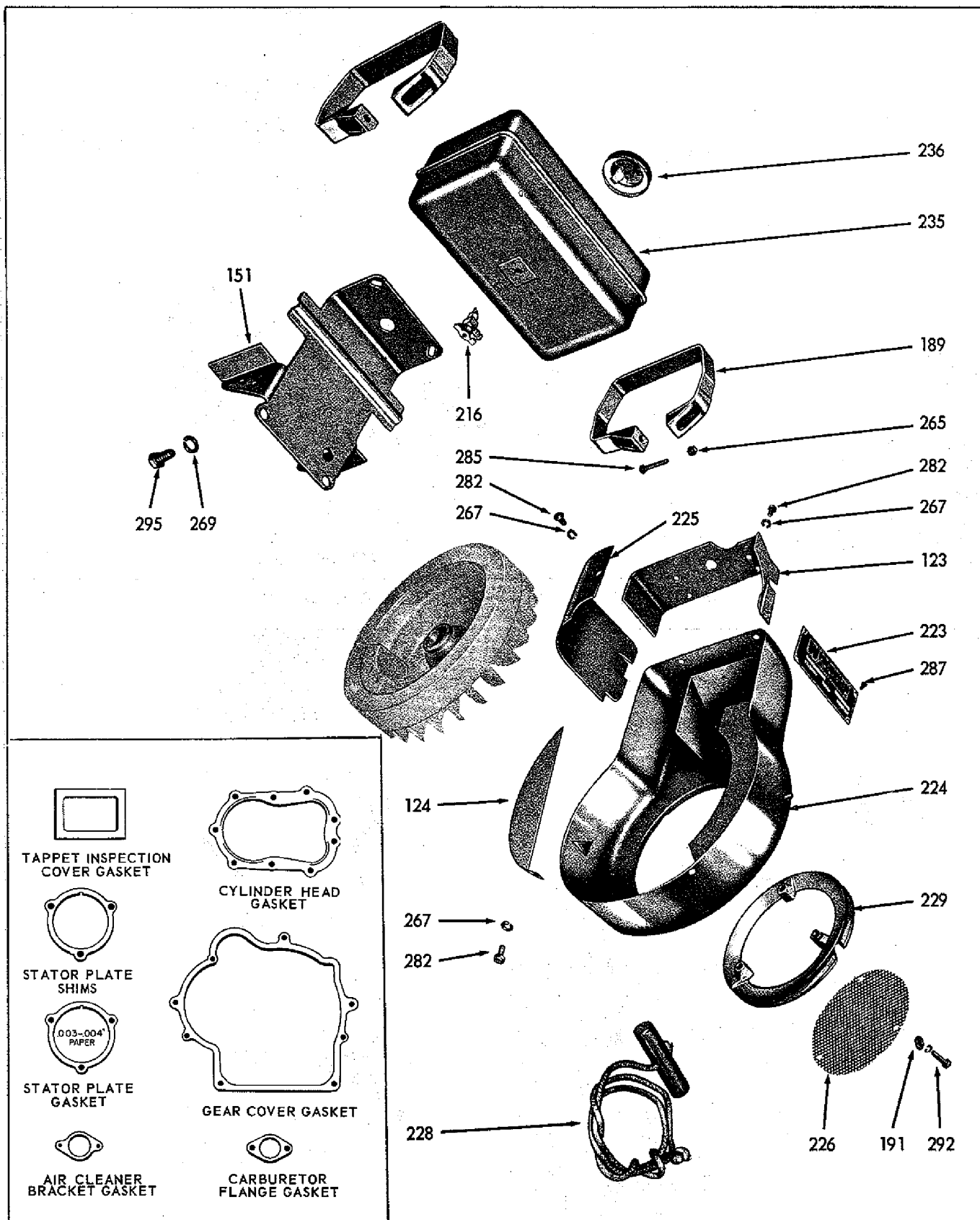

Ref. No. 119, GASKET SET

AIR SHROUDING and FUEL TANK GROUP

285311C-2

Parts are identified by reference number. See parts list for correct part number.

PARTS FOR ENGINE MODELS S-7D AND S-8D

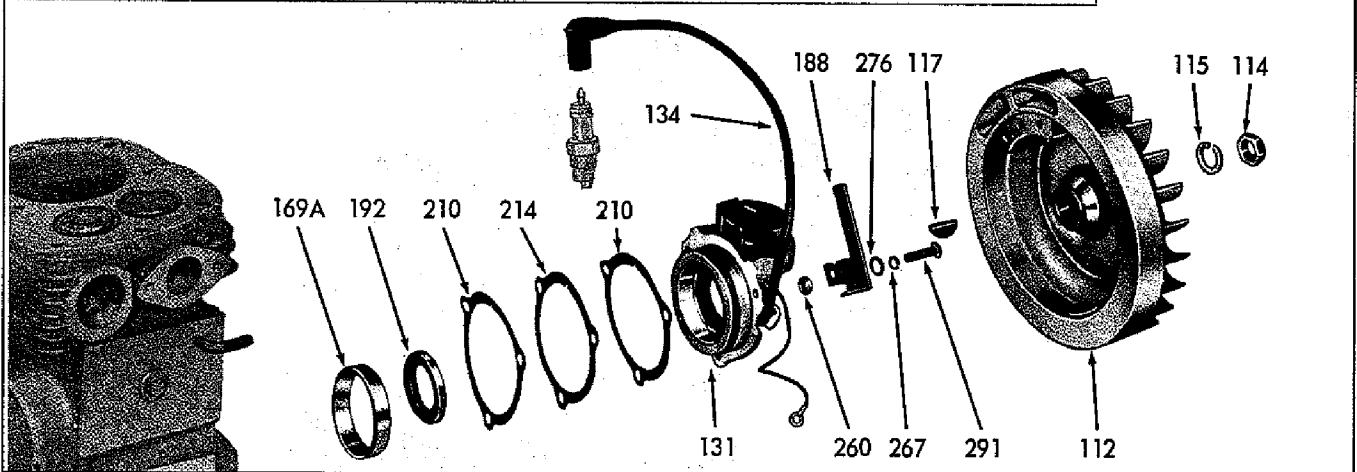
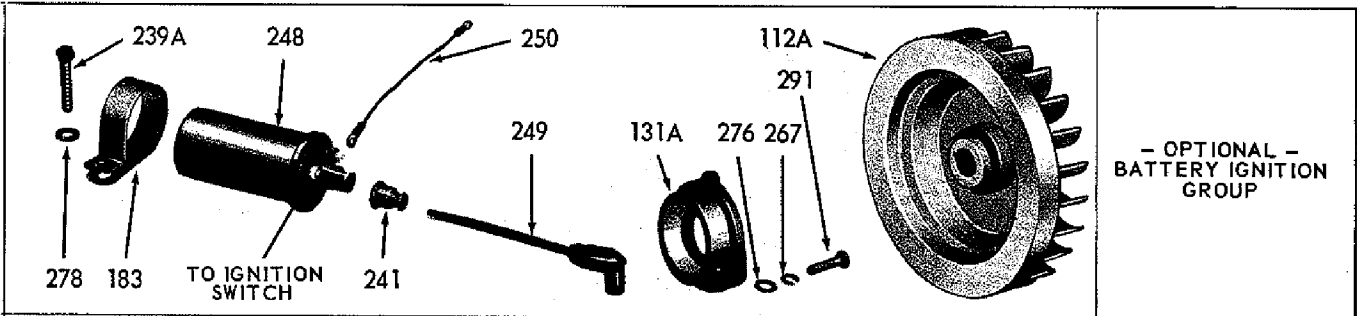

MAGNETO STATOR PLATE and FLYWHEEL GROUP

303973C

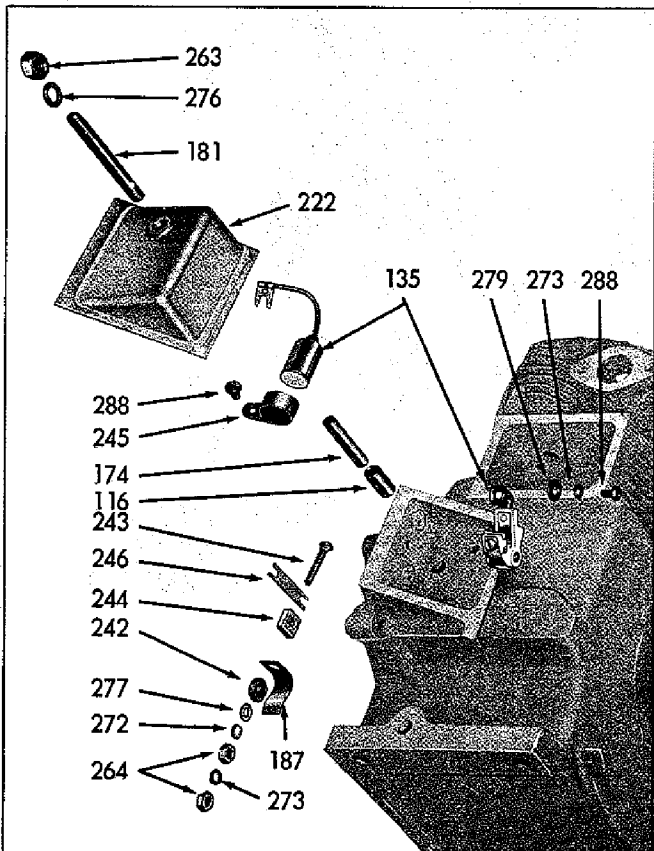

285306C

BREAKER POINT GROUP for MODEL S-8D

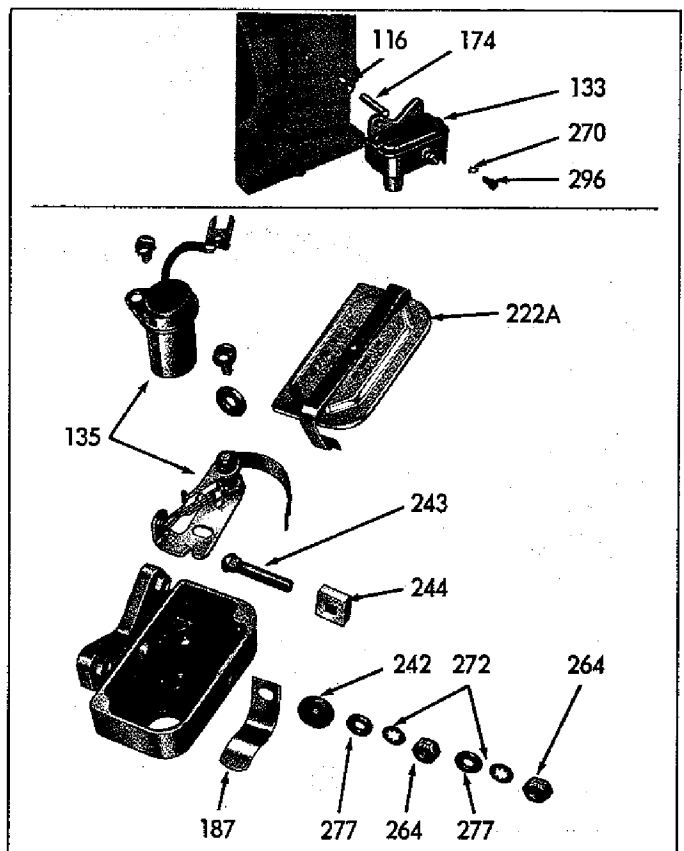

308366C

BREAKER POINT GROUP for MODEL S-7D

Parts are identified by reference number. See parts list for correct part number.

WALBRO CARBURETOR and AIR CLEANER GROUP for model S-8D

Beginning with engine serial number 5558441

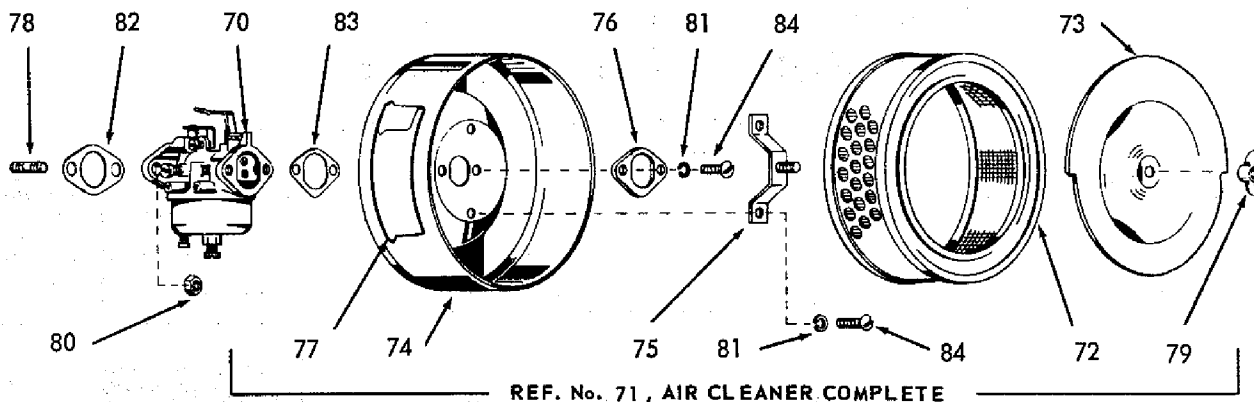

SERVICE PARTS LIST of all parts related to this change.

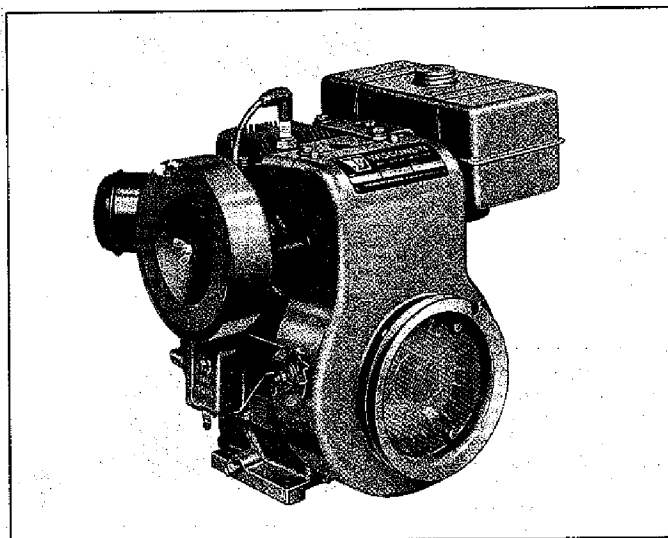

Ref. No.	Part Number	Description	No. Req.	Net Wt.	
				Lb	Oz
78	PC-631	STUD, carburetor mounting	2		1
79	PD-147	WING NUT, air cleaner mounting	1		1
80	PD-254	LOCKNUT (special), carburetor mtg.	2		1
81	PE-14	LOCKWASHER, no. 10, spring lock For air cleaner mounting	4		1
119	Q-36-C	ENGINE GASKET SET	1		8
page 31		Q-36-B, replaced by Q-36-C			
82	QC-53-C	GASKET, carburetor flange (1/8").....	1		1
83	QD-849	GASKET, air cleaner to carburetor	1		1
221	SA-149	COVER, valve tappet	1		5
page 30					
126	T-112	GOVERNOR ASSEMBLY complete	1	1	
page 30		Same as T-108 governor except:			
127	page 30	VE-844 Rod replaces VE-783-C.....	1		1
200	page 30	PK-178 Clip, replaces PK-177	1		1
84	XA-7	SCREW, 10- 32 x 3/8 long round head For air cleaner mounting	4		1
151	BK-125	FUEL TANK BRACKET	1	2	8
page 31		BK-125-S1 TANK-BRACKET		4	8
		Assembly with strapping			
Not ILL.	PH-515	GROMMET, fuel line, in flywheel shroud	3		1

Ref. No.	Part Number	Description	No. Req.	Net Wt.	
				Lb	Oz
70	L-104-S1	CARBURETOR, WALBRO No. LME-73	1	1	
		LQ-52 Repair Kit	1		6
		Q-45 Gasket Set (carburetor).....	1		1
<p>NOTE: Specify the part number or model designation, stamped on carburetor, when ordering replacement carburetor or parts. See carburetor bulletin ML-33-3 in back of manual for service parts.</p>					
163	LL-178-A	HOSE, crankcase breather.....	1		1
page 28					
71	LO-194	AIR CLEANER, complete	1	1	8
		Consisting of:			
72	LO-194-A	ELEMENT	1		6
73	LO-194-C	COVER	1		4
74	LO-194-D	HOUSING	1		12
75	LO-194-E	BRACKET	1		1
76	QF-119	SPACER	1		1
77	SD-308	INSTRUCTION DECAL	1		1
		Also includes mounting parts, ref. no's. 79, 81, 83, 84			

Order parts from nearest **WISCONSIN DISTRIBUTOR** or **SERVICE CENTER.**

PARTS LIST

For Standard MAGNETO IGNITION Engines, and BATTERY IGNITION
REWIND STARTER, form MU-4A-3 in rear section of manual

Models S-7D and S-8D

THE FOLLOWING ARE NON-INTERCHANGEABLE PARTS BETWEEN MODELS S-7D AND S-8D

REF. NO.	PART NUMBER		DESCRIPTION	NO. REQ.	NET WEIGHT	
	MODEL S-7D	MODEL S-8D			LBS	OZ
101	See Fig. A 3" Bore	See Fig. A 3-1/8" Bore	CYLINDER and CRANKCASE ASSEMBLY Complete with valves, springs, seats, locks, insert, valve guides, governor shaft, breaker rod bushing, breather, inspection cover and gasket. NOTE: The basic and standard cylinder-crankcase part number is AA-103 for Model S-7D and AA-107 for Model S-8D. Any special machining is indicated by a number stamped on the case, in the location shown in Fig. A. Add this number to the basic cylinder-crankcase part number. The further addition of an S1, specifies the cylinder-crankcase is complete with valves, springs, seats and etc. Order by this number and by giving the Model, Specification and Serial numbers of the engine.	1	29	
102	AB 108 D	AB 112 A	CYLINDER HEAD AB 108 B, replaced by AB 108 D.	1	2	12
103	CA 79 etc. (Ref. to Note and Fig. B)	CA 82 etc.	CRANKSHAFT ASSEMBLY Includes: 1 GA 45 Gear 2 ME 170 Bearings 1 PL 21 Key NOTE: The standard and basic engine crankshaft part number, as listed in part number column, can be identified by raised letters on the side of the counter-weight. Dash numbers are added to the basic part number to identify special machining at the take-off end. The dash (-) number will be found stamped on the cheek facing the flywheel end of the shaft, as illustrated in Fig. B. Order by complete part number, (dash number added to basic number), and by giving Model, Specification and Serial Numbers of the engine.	1	9	
104	DB 224	DB 230	PISTON , standard size, cam ground Pistons are also furnished .010", .020" and .030" oversize.	1		8
106	DR 53	DR 54 A	PISTON RING SET , standard size Consisting of:	1		4
106A	DC 318	DC 347	COMPRESSION RING , top groove	1		1
106B	DC 319	DC 315	SCRAPER RING , 2nd groove	1		1
106C	DC 294	DC 316	OIL RING , 3rd groove	1		1
106D	DC 295	DC 317	EXPANDER for oil ring, 3rd groove	1		1
	DR 51	DR 55	TRI CROME RE-RING SET , standard size NOTE: Piston ring sets are also furnished .010", .020" and .030" oversize.			
108	EA 129 A	EA 130 C	CAMSHAFT ASSEMBLY with gear and compression release For engines beginning with Serial No. 4289760. EA 121 B Camshaft (less compression release) for S-7D EA 123 D Camshaft (less compression release) for S-8D NOTE: For replacement, use compression release camshaft assembly. EA 130 A, for S-8D, replaced by EA 130 C.	1	1	14
					2	8
					2	8
109	FA 46	FA 47	VALVE TAPPET	2		2

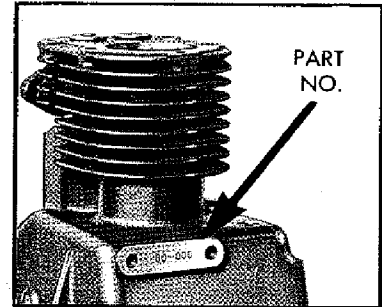

Fig. A 90845C

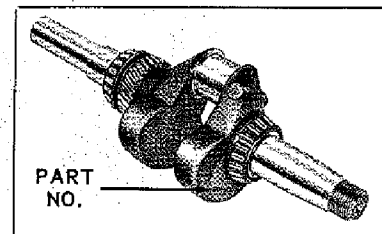

Fig. B 290652C

Order parts from nearest **WISCONSIN DISTRIBUTOR** or **SERVICE CENTER**.

IMPORTANT: Always give Model, Specification and Serial Numbers as shown on name plate.

NON-INTERCHANGEABLE PARTS of Models S-7D and S-8D

REF. NO.	PART NUMBER		DESCRIPTION	NO. REQ.	NET WEIGHT	
	MODEL S-7D	MODEL S-8D			LBS	OZ
			NOTE: Beginning with engine Serial #5558441, the L 104 S1 Walbro carburetor along with related Air Cleaner and linkage on page 32a, replaces the Zenith carburetor on all standard production Model S-8D engines. Zenith carburetors and parts are available for service.			
110	L 80 L S1 (12924) L 80 M S1 (12925)	L 80 K S1 (12931) L 80 P S1 (12947)	ZENITH CARBURETOR, for gravity feed LQ 40 Repair Kit ZENITH CARBURETOR, for engines with fuel pump LQ 42 Repair Kit	1 1 1 1	1	8 2 2
112	NC 198 A (11 lbs.) NC 198 (12 lbs.)	N 109 A N 109 A 1 N 109 A 1 S1	FLYWHEEL, with magnet - used with Wico magneto and Rewind Start FLYWHEEL, - additional tapped holes for Rope or Motor-Generator Pulley.. NC 203 Flywheel, replaced by N 109 A 1. FLYWHEEL assembly - used with obsolete Fairbanks-Morse magneto NOTE: Fairbanks-Morse and Wico flywheels are not interchangeable with each other, unless the corresponding manufacturers coil-stator plate, (Ref. 131) is used.	1 1 1	11 11 11	12 8
112A	NC 202	NC 202-2	FLYWHEEL, battery ignition engines - with tapped holes for drive sheave	1	13	
114	PD 162 (5/8"-18)	PD 137 (1"-14) PD 137-1	NUT, for mounting flywheel - with Rope or Motor-Generator Pulley JAM NUT (5/16" thick), flywheel mounting with Rewind Start	1 1		1 1
115	PE 37 (5/8" spr.)	PE 58 (1" I.T.)	LOCKWASHER, for mounting flywheel	1		1
116	PF 150 A S1	PF 157 A S1	BREAKER BUSHING and PIN KIT For field replacement of PF 150 bushing on S-7D, or PF 157 for S-8D. Kits include PA 428 L S1 push pin and spring.	1		3
117	PL 17 (#13)	PL 47 (#18)	WOODRUFF KEY, for mounting flywheel	1		1
119	Q 35 B	Q 36 C	ENGINE GASKET SET	1		8
120	QC 53 B	QC 53 C QC 53	GASKET, carburetor flange - 1/8" thick for Walbro carburetor GASKET, 1/32" thick for Zenith carburetor	1 1		1 1
121	QD 797	QD 825	GASKET, cylinder head	1		1
123	SE 272 B	SE 297	COVER, cylinder head	1		4
124	None Used	SE 282	BACK PLATE, for flywheel shroud	1		3
126	T 105 B	T 108 T 112	GOVERNOR assembly (see page 30), with Zenith carburetor GOVERNOR assembly complete, with Walbro carburetor	1 1	1 1	
127	VE 783 B	VE 783 C VE 844	ROD, governor control with Zenith carburetor ROD, governor control with Walbro carburetor	1 1		1 1
129	XD 20 (1-3/8" long)	XD 21 (1-1/2" long)	SCREW, (special hardness), 5/16"-18 thread For mounting cylinder head.	4 (S-7D) 5 (S-8D)		1
130	XD 74 (2-1/4" long)	XD 147 (2-1/2" long)	SCREW, 1/4"-20 thread, hexagon head For mounting valve inspection cover.	1		1
131	Y 126 A S1 Y 126 S1	Y137 S1 (Beginning with S/N 6039991) Y 131 S1	STATOR PLATE assembly, for Wico magneto Both assemblies include: ME 170-1 Bearing Cup PH 529 Oil seal 90 X 13000 Coil assembly (includes ignition cable) 90 11409 Coil clip NOTE: Y 130 S1 used previous to S/N 6039991. STATOR PLATE assembly, for obsolete Fairbanks-Morse magneto Both assemblies include: ME 170-1 Bearing Cup PH 529 Oil seal 31 X 2477 Coil assembly (includes ignition cable) 31 D 2476 Coil clip	1 1	1 1	8 8
			NOTE: Fairbanks-Morse and Wico stator plate assemblies are not interchangeable with each other unless the corresponding manufacturer's flywheel (Ref. 112) is used.			

Order parts from nearest **WISCONSIN DISTRIBUTOR** or **SERVICE CENTER**.

IMPORTANT: Always give Model, Specification and Serial Numbers as shown on name plate.

NON-INTERCHANGEABLE PARTS of Models S-7D and S-8D

REF. NO.	PART NUMBER		DESCRIPTION	NO. REQ.	NET WEIGHT	
	MODEL S-7D	MODEL S-8D			LBS	OZ
131A	BG 334 S1	BG 334-1 S1	BEARING PLATE assembly, (in place of stator plate) For battery ignition engines. Includes: ME 170-1 bearing cup, PH 529 oil seal.	1	1	
133	YD 308 A S1 (Includes Push Pin)	YD 318 (Not serviced as a unit)	BREAKER BOX assembly, complete (page 32) For either Fairbanks-Morse or Wico magnetos and battery ignition.	1		6
134	YL 339 B 18	YL 339 B 20	CABLE , high tension, magneto coil to spark plug	1		2
135	YQ 11	YQ 12	POINTS and CONDENSER KIT	1		4
NOTE: The other serviceable component parts of the breaker assembly are contained in the following interchangeable listing of parts.						

PARTS INTERCHANGEABLE for Models S-7D and S-8D, except where noted.

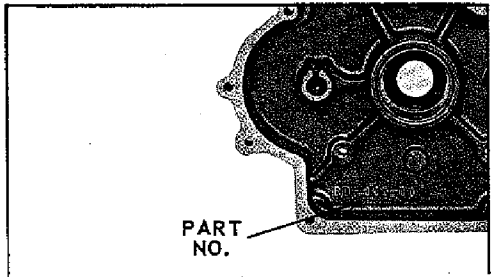
Ref. No.	Part Number	Description	No. Req.	Net Wt.		Ref. No.	Part Number	Description	No. Req.	Net Wt.	
				Lb	Oz					Lb	Oz
138	AD 41 E	GUIDE, valve stem inlet and exhaust ..	2		1	149	BI 364C S3	BRACKET , air cleaner For ZENITH carburetor. Consisting of: BI 364 C Bracket LL 178-5 Breather hose	1		7
139	AE 74 D	VALVE, exhaust	1		4						
140	AE 96	VALVE, inlet	1		4						
141	AF 43 B	VALVE SPRING, inlet and exhaust	2		2	150	BI 377	ADAPTER for ZENITH carburetor, dry element air cleaner	1		2
142	AG 26	SEAT, valve spring inlet	1		1	151	BK 125	BRACKET , fuel tank	1	2	8
143	AG 31	ROTO-CAP and SEAT for exhaust valve	1		1		BK 120 B	For WALBRO carburetor. BK 125 S1 tank-bracket with strapping BRACKET , fuel tank	1		5
144	AG 34 A	CUP, valve spring locating	2		1			BK 120B S1 tank-bracket with strapping For ZENITH carburetor.	1		2
146	AH 9	LOCK, valve spring seat (2 pair)	4		1			BK 120B S1 tank-bracket with strapping NOTE: For tank service straps, see Ref. 189.	4		8
147	See Fig. C	GEAR COVER assembly Includes: 1 ME170-1 Brg. cup 1 PH529 Oil seal 1 PH568 Oil seal	1	7	6	153	DA 83A S1	CONNECTING ROD assembly, with integral oil dipper	1		7½
NOTE: The standard gear cover part number for this model engine is BD 111 F. Any special machining would be indicated by a number stamped behind the basic BD 111 F cast part number. See Fig. C.											
Order by part number and by giving Model, Specification and Serial numbers of engine.											
BD 111 etc. Gear Cover, replaced by BD 111 F etc.											
											
Fig. C 290653C-1											
						154	DA 73C 4 S1 (Obsolete)	CONNECTING ROD with steel stamped dipper. Includes: 2 HF 617 Dowels 1 PE 109 Lock 1 PG 1075A Dipper 2 XD 22 Screws For complete replacement use DA 83A S1.			8
								NOTE: Connecting rods are also furnished .010", .020" and .030" undersize.			
						155	DE 65	PISTON PIN	1		3
						156	GA 45	CRANKSHAFT GEAR	1		5
						158	GD 146 A	GOV. GEAR and FLYWEIGHT assembly GD 137 F, replaced by GD 146 A. GD 137 E Assembly (not available), used on engines to and including serial No. 3909151. For replacement of obsolete GD 137 E, use GD 146A S1 Service Kit.	1		4
						(Continued)					

Order parts from nearest **WISCONSIN DISTRIBUTOR** or **SERVICE CENTER**.

IMPORTANT: Always give Model, Specification and Serial Numbers as shown on name plate.

PARTS INTERCHANGEABLE for Models S-7D and S-8D, except where noted.

Ref. No.	Part Number	Description	No.			Net Wt.			Ref. No.	Part Number	Description	No.			Net Wt.		
			Req	Lb	Oz	Req	Lb	Oz				Req	Lb	Oz	Req	Lb	Oz
	GD 146 A S1	GOVERNOR GEAR and FLYWEIGHT KIT for engines to and including Serial No. 3909151 Consisting of: GD 146 A Gear and Flyweights PA 395 B Fulcrum Shaft PI 217-3 Adjusting Screw PI 217-4 Adjusting Screw PK 135 Snap Ring PM 200 A Governor Spring	1		8				177	Not serviced	FULCRUM PIN for compression release flyweight	1		1			
159	HF 52	SPACER for governor control disc	1		1			178	PC 377	STUD for governor control disc	1		1				
160	HF 426 (Obsolete)	SPACER for governor fulcrum shaft Used on engines previous to Serial No. 3909152. Replaced by PK 135 Retaining Ring and PA 395 B Fulcrum Shaft.	1		1			179	PC 561	STUD (6-7/16" long) for LO 87 oil bath air cleaner mounting	1		2				
161	HG 201 D	INSERT , valve seat exhaust	1		1			180	PC 600	STUD (7" long) for LO 173 dry element air cleaner mounting	1		2				
162	LJ 158	NIPPLE , 1" x 3" long pipe For muffler mounting.	1		6			181	PC 590	STUD for breaker cover (S-8D)	1		1				
163	LL 178 A	HOSE , breather line, 1/4" I.D. x 3-5/8" long Used with WALBRO carburetor.	1		1			182	PD 147	WING NUT , for air cleaner mounting	1		1				
	LL 178-5	HOSE , breather line, 1/4" I.D. x 5" long Used with ZENITH carburetor. LL 164-4 (3/16" I.D.) replaced by LL 178-5 with 2 LK 30 clamps.	1		1			183	PG 556	STRAP , for battery ignition coil	1		4				
164	LL 178-16	HOSE , for fuel line, 1/4" I.D. LL 164-16 (3/16" I.D.), replaced by LL 178-16 with 2 LK 30 clamps.	1		2			185	PG 1019 A	GOVERNOR VANE	1		1				
	LK 30	HOSE CLAMPS for fuel line (not illust.)	2		1			186	PG 1073	REED , for crankcase breather	1		1				
165	LO 87	AIR CLEANER , oil bath type Used with ZENITH carburetor. Consisting of: 81 A 10187K01 Cover and element assem. 81 A 10186K01 Body and tube assembly	1	1	2			187	PG 1132	CLIP , magneto ground	1		1				
165A		QD 744 A Gasket	1		1			188	PG 1144-2	CLIP , for ignition wires support	1		3				
165B		SD 165 Instruction decal	1		1			189	PG 1201	FUEL TANK STRAP PG 733, replaced by PG 1201.	2		6				
165C								NOTE: Steel Binder Strapping and Seal for mounting fuel tank on engines sent out from the factory are not serviceable in the field. Order 2 PG 1201 straps with 2 ea. XA 69 screws and PD 239 nuts.									
165D																	
167	LO 173	AIR CLEANER , dry element type Used with ZENITH carburetor. Consisting of: LO 173 A Cover LO 173 B S3 Element (3 pack) SD 276 Instruction decal	1	1				191	PH 442	WASHER , (rubber faced) For valve inspection cover.	1		1				
167A			1		8			191	PH 196	WASHER , 1/4" plain steel For starter sheave mounting. (Replaces PH 442 rubber faced washer)	3		1				
167B			1		8			192	PH 529	OIL SEAL , for crankshaft 1 - in gear cover. 1 - in stator plate. PH 529 A (in gear cover) for engines with gear reduction units.	2		2				
167C			1		1			193	PH 546	SPRING WASHER , for breather reed	1		1				
168	ME 37	STEEL BALL for cam shaft, 3/8" dia.	1		1			194	PH 568	OIL SEAL , for gov. lever shaft (1/2" O.D.) with BD 111 F gear cover PH 556 (7/16" O.D.) oil seal for obsolete BD 111 gear cover - use PH 568 and ctr. bore .502-.497", 3/16" deep	1		1				
169	ME 170	MAIN BEARING assembly Consisting of: 1 ME 170-1 Bearing cup * 1 ME 170-2 Bearing cone * * Not sold separately - order ME 170.	2		8			196	PI 217-3	ADJUSTING SCREW , governor spring, 5-5/8" long, beginning with engine No. 3909152 For speeds to and including 2900 R.P.M. 5 1/2" long, above 2900 R.P.M. load, and for engines previous to Serial No. 3909152, to and including 2800 R.P.M. PI 217-1 (5" long) for engines previous to Serial No. 3909152, above 2800 R.P.M. load	1		1				
169A					3				197	PK 52	RING , piston pin retaining	2		1			
169B					5				198	PK 135	RETAINING RING , (inner) for governor lever shaft, on engines beginning with Serial No. 3909152	1		1			
171	PA 395 B	FULCRUM SHAFT for governor lever.. PA 395, replaced by PA 395 B.	1		2			199	PK 144	RETAINING RING 1-for governor lever shaft (outer). 1-for compression release.	2		1				
172	PA 396 A	SHAFT for governor gear PA 396, replaced by PA 396 A.	1		1			200	PK 178	CLIP , throttle rod mounting PK 160, replaced by PK 178.	1		1				
173	PA 425	DOWEL PIN for gear cover	2		1			201	PK 167	SNAP RING , for governor gear, beginning with Engine Serial No. 3909152	1		1				
174	PA 428 L S1	PUSH PIN and SPRING assembly For breaker points. Includes: PM 221 SPRING PA 428 E, PA 428 K S1, replaced by PA 428 L S1. PA 394 Push rod (1" long) Use with obsolete sheet metal breaker box (S-7D).	1		1			202	PL 21	WOODRUFF KEY , No. 3 For crankshaft gear mounting.	1		1				
176	PA 455-2	SPOILER CAM for compression release	1		1												

Order parts from nearest **WISCONSIN DISTRIBUTOR** or **SERVICE CENTER**.
IMPORTANT: Always give Model, Specification and Serial Numbers as shown on name plate.

PARTS INTERCHANGEABLE for Models S-7D and S-8D, except where noted.

Ref. No.	Part Number	Description	No.			Net Wt.		
			Req	Lb	Oz	Req	Lb	Oz
204	PM 108	SPRING, camshaft thrust	1		1			
205	PM 200 A	GOVERNOR SPRING, (47 coils) for engines beginning with Serial No. 3909152 PM 200 (55 coils) for engines previous to Serial No. 3909152	1		1			
206	PM 232	SPRING, for compression release	1		1			
208	QD 744 A	GASKET, air cleaner base, ZENITH carburetor	1		1			
209	QD 798 A	GASKET, for gear cover	1		1			
210	QD 848	GASKET, stator plate, .003-.004" thick QD 799 A, replaced by QD 848.	*		1			
	QD 848 A	GASKET, .006 - .007" thick	*		1			
		* Use as required with QF 121 Shims to give .002 to .005" crankshaft end play. 2 and 3 furnished in gasket set.						
211	QD 800	GASKET, air cleaner bracket	1		1			
		Used with ZENITH carburetor.						
212	QD 801	GASKET, for tappet inspection cover ..	1		1			
214	QF 121	SHIM, for stator plate, .010" thick steel QF 114 A (plastic, replaced by QF 121. * Use as required to give .002 to .005" crankshaft end play. 3 in gasket set.	*		1			
215	RF 1439	ELBOW, in carburetor, for fuel line	1		1			
216	RG 41	VALVE and STRAINER,	1		2			
		Fuel tank shut-off.						
217	RJ 141-5	DIP STICK, (screw in)	1		3			
	Optional	Saber Type						
218	RJ 171	DIP STICK, (long hook)			3			
	RJ 171 A	DIP STICK, (short hook)			2			
219	LJ 438	TUBE, (for saber type dip stick)			2			
221	SA 124	COVER, valve tappet, with ZENITH carburetor	1		5			
	SA 149	COVER, valve tappet, with WALBRO carburetor	1		5			
222	SA 130 A	COVER, for breaker points (S-8D)	1		3			
222A	SA 126 A	COVER, for breaker box (S-7D)	1		2			
223	SD 312 A	NAME PLATE	1		1			
		When ordering name plate, give model, specification and serial numbers for correct stamping.						
224	SE 270 B 1	FLYWHEEL SHROUD, Rewind Starting	1		2			
	SE 270 B	Rope Starting, less rewind mtg. holes						
225	SE 271	CYLINDER SIDE SHROUD	1		4			
226	SE 273	SCREEN, for rope sheave	1		1			
228	U 268	STARTING ROPE assembly	1		6			
229	UC 203 A	STARTING SHEAVE, (sheet metal)	1		1			
		Order screen separately.						
		UC 203 replaced by UC 203A.						
		UC 184 (Aluminum sheave), replaced by JC 203 A and 3 XD 150 screws						
		3 PH 196 washers						
		3 PE 3 lockwashers.						
230	VB 260	FLYWEIGHT, compression release	1		2			
231	VB 234 A S1	GOVERNOR LEVER assembly	1		2			
		Includes: PD 239 Nut, XA 36 Screw, PH 27 A Washer.						
232	VC 43 A	DISC assembly, for gov. control rod ...	1		3			
		Includes:						
		1 PH 324 Washer 1 VE 814 Swivel block						
234	WD 64 S5	MUFFLER, (less pipe nipple)	1		1			
		WD 64 S1 with LJ 158 pipe nipple.						
235	WE 413 S1	FUEL TANK with RC 122 filler cap	1		2			
		WE 409 and WE 411 tank with RC 77 cap, replaced by WE 413 S1.						
		See Ref. 151 for Bracket-Tank assembly WE 343 C (small seam tank) for engines previous to Serial No. 4213945, no longer available - for replacement order BK 120 B S1 Assembly (WE 413 Tank, BK 120 B bracket and steel binder strapping).						
		NOTE: Fuel tank is mounted to bracket with steel binder strapping which is not serviceable. When replacing fuel tank only, order replacement straps (Ref. 189).						
236	RC 122	CAP, (screw type) for WE 413 tank	1		2			
	RC 123 A	CAP, with gauge, available for WE 413 fuel tank			4			
		RC 77 cap for obsolete WE 411, WE 409, WE 343 bayonet neck type fuel tanks ..			2			
238	XD 20	SCREW, (Special hardness) 5/16"-18 thread x 1-3/8" long, hexagon head	2		1			
		For connecting rod (DA 80 A S1).						
		XD 22, 1 3/4" long for DA 73 C 4 S1	2		1			
239	XD 140	SCREW, (Special hardness) 5/16"-18 thread x 2 1/4" long, hexagon head	4		1			
		For mounting cylinder head.						
239A	XD 162	SCREW, (Special hardness) 5/16"-18 thread x 2 1/2" long, hexagon head	1		1			
		For mounting cylinder head and battery ignition coil strap.						
240	YD 6 S1	SPARK PLUG, 18mm, Champion #D-16J	1		3			
	Optional							
	YD 6 S2	SPARK PLUG, AC #C86 Commercial .			3			
241	YD 20 A	RUBBER NIPPLE, for coil terminal ...	1		1			
		(Battery ignition engine).						
242	YD 316	INSULATING WASHER (outer) for ground stud	1		1			
243	YD 321	TERMINAL STUD, for ground clip	1		1			
244	YD 324	INSULATING WASHER, (inner) for ground stud	1		1			
245	YD 325	CLAMP, condenser (S-8D)	1		1			
246	YD 326	TERMINAL STRIP,	1		1			
		For breaker arm (S-8D).						
248	YF 38 A	COIL, (12 volt) for battery ignition	1		1		6	
		YF 5 B, replaced by YF 38 A.						
249	YL 339-6	HIGH TENSION LEAD	1		2			
		For battery ignition coil.						
250	YL 352-16	IGNITION WIRE, breaker box to battery ignition coil	1		1			
		FUEL PUMP MOUNTING (Not part of standard engine)						
253	LL 178-8	FUEL LINE, pump to carburetor	1		1			
254	LP 62 E S1	FUEL PUMP, with gasket (S-7D)	1		10			
	LP 62 G S1	FUEL PUMP, with gasket (S-8D)	1		10			
		LQ 51 Repair Kit for LP 62 E, G S1 ..	1		4			
		LP 42 L S1, replaced by LP 62 E S1.						
		LP 42 N S1, replaced by LP 62 G S1.						
		LQ 28 Repair Kit for LP 42 L, N S1 ..	1		4			
		NOTE: Refer to fuel pump instruction sheet in rear of manual for maintenance and repair.						

Order parts from nearest **WISCONSIN DISTRIBUTOR** or **SERVICE CENTER**.
IMPORTANT: Always give Model, Specification and Serial Numbers as shown on name plate.

PARTS INTERCHANGEABLE for Models S-7D and S-8D, except where noted.

Ref. No.	Part Number	Description	No. Req.	Net Wt.		Ref. No.	Part Number	Description	No. Req.	Net Wt.	
				Lb	Oz					Lb	Oz
255	QD 670	FLANGE GASKET	1		1	284	XA 36	SCREW, 1/4"-20 thread x 3/4" long, indented hexagon head	1		1
256	RF 269	STRAIGHT FITTING, for fuel inlet	1		1			For governor lever clamp.			
257	RF 1439	ELBOW, in pump outlet	1		1	285	XA 69	SCREW, 1/4"-20 thread x 2" long, round head	2		1
		STANDARD HARDWARE						For fuel tank service straps.			
260	HF 390	SPACER, 9/32" I.D. x 5/8" O.D. x 1/8" thick	1		1	286	XA 66	SCREW, No. 5-40 thread x 1/4" long, round head	1		1
		For stator plate ignition wire clip.						For governor vane to shaft.			
262	PD 9	NUT, 1/4"-28 thread, hexagon steel	1		1	287	XA 67	SCREW, No. 4 x 1/4" long, self-tapping sheet metal	4		1
		For governor control disc stud.						For name plate to shroud.			
263	PD 77	NUT, 1/4"-20 thread, hexagon steel	1		1	288	XA 126	SCREW, No. 8-32 thread x 1/2" long, plated pan head	3		1
		For breaker cover (S-8D).						1-for breaker point bracket (S-8D).			
264	PD 153-2	NUT, No. 8-32, hexagon steel	2		1			1-for condenser mounting (S-8D).			
		For ground terminal stud.						1-for breather reed mounting.			
265	PD 239	NUT, 1/4"-20 thread square steel	3		1			XA 80, XA 118 (5/16" lg.), replaced by XA 126.			
		1-for governor lever clamp.				290	XD 6	SCREW, 1/4"-20 x 3/4" long, hex head	4		1
		2-for fuel tank straps.						2-for mounting carburetor.			
267	PE 3	LOCKWASHER, 1/4" spring lock	22		1			2-for mounting fuel pump.			
		6-for gear cover to crankcase.				291	XB 82	SCREW, 1/4"-20 x 1" long, hex head .	3		1
		2-for carburetor mounting.						For coil-stator plate, or fan end bearing plate mounting.			
		5-for shrouding.				292	XD 150	SCREW, 1/4"-20 x 1-1/8" long, hex head	3		1
		1-for governor control disc.						For UC 203A starting sheave mounting.			
		3-for stator plate.						XD 5 (5/8" long), for obsolete UC 203.	3		1
269	PE 5	LOCKWASHER, 3/8" spring lock	2		1			XD 8 (1 1/4" long) for obsolete UC 184	3		1
		For mounting fuel tank bracket.				293	XD 9	SCREW, 1/4"-20 x 1 1/2" long, hex head .	6		1
270	PE 45	LOCKWASHER, No. 10, external	2		1			For gear cover to crankcase.			
		For breaker box mounting (S-7D).				295	XD 25	SCREW, 3/8"-16 x 3/4" long, hex head	2		1
271	PE 114	SCREW LOCK, for connecting rod	2		1			For mounting fuel tank bracket.			
		PE 46 5/16" ext. tooth lockwasher replaced by PE 114.				296	XD 158	SCREW, No. 10-32 thread x 1/2" long, indented hex head	2		1
								For breaker box to crankcase (S-7D).			
272	PE 72	LOCKWASHER, No. 8 internal	1		1			XA 8, replaced by XD 158.			
		For ground clip.				297	XK 2	PIPE PLUG, 1/4" square head	1		1
		2 required for (S-7D).						For oil drain.			
273	PE 89	LOCKWASHER, No. 8 spring lock	2		1						
		1-for ground clip (S-8D).									
		1-for breaker point bracket (S-8D).									
275	PH 27 A	PLAIN WASHER, 1/4" I.D. x 9/16" O.D.	1		1						
		For gov. lever clamp screw.									
276	PH 30 A	PLAIN WASHER, 1/4" steel	5		1						
		3-for coil-stator plate mounting.									
		1-for breaker cover (S-8D).									
		1-for governor fulcrum shaft.									
277	PH 86 B	PLAIN WASHER, 11/64" I.D. x 3/8" O.D.	1		1						
		For ground terminal stud.									
278	PH 209 B	PLAIN WASHER, 5/16" steel	9		1						
		For cylinder head mounting.									
		8 required for (S-7D).									
279	PH 236	PLAIN WASHER, 11/64" I.D. x 1/2" O.D.	1		1						
		For breaker point bracket (S-8D).									
281	XA 9	SCREW, No. 10-32 thread x 5/8" long, round head	2		1						
		For air cleaner bracket to carburetor.									
282	XA 34	SCREW, 1/4"-20 x 1/2" long, hex. head ..	5		1						
		2-for flywheel shroud to crankcase.									
		2-for flywheel shroud to cylinder head.									
		1-for cylinder side shroud to crankcase									

Order parts from nearest **WISCONSIN DISTRIBUTOR** or **SERVICE CENTER**.
IMPORTANT: Always give Model, Specification and Serial Numbers as shown on name plate.