

CONTINENTAL DIESEL ENGINES

**T
M
D

S
E
R
I
E
S**

OPERATORS GUIDE & REPAIR MANUAL



**WISCONSIN
MOTORS, LLC**

2020 Fletcher Creek Drive, Memphis, Tennessee 38133
www.wisconsinmotors.com
(800) 932-2858

FORWARD

Good operation and a planned maintenance program as outlined in this manual are vital in obtaining maximum engine performance and long engine life. The instructions on the following pages have been written with this in mind, to give the operator a better understanding of the various problems which may arise, and the manner in which these problems can best be solved or avoided.

The operator is cautioned against the use of any parts, other than genuine Wisconsin Motors, LLC parts, for replacement or repair. These parts have been engineered and tested for their particular job, and the use of any other parts may result in unsatisfactory performance and short engine life.

Wisconsin Motors, LLC distributors and dealers, because of their close factory relations, can render the best and most efficient service.

THE LIFE OF YOUR ENGINE DEPENDS ON THE CARE IT RECEIVES

The MODEL, SPECIFICATION and SERIAL NUMBER of your engine must be given when ordering parts. The MODEL and SPECIFICATION number are on the nameplate. The SERIAL NUMBER is stamped either on the crankcase or the engine's identification tag.

Copy the MODEL, SPECIFICATION and SERIAL NUMBER in the spaces provided below so that it will be available when ordering parts.

MODEL	SPECIFICATION
<input type="text"/>	<input type="text"/>
SERIAL NUMBER	
<input type="text"/>	

To insure prompt and accurate service, the following information must also be given:

1. State EXACTLY the quantity of each part and part number.
2. State definitely whether parts are to be shipped by express, freight or parcel post.
3. State the exact mailing address.

IMPORTANT

READ THESE INSTRUCTIONS CAREFULLY

All points of operation and maintenance have been covered as carefully as possible, but if further information is required, send inquiries to the factory for prompt attention.

When writing to the factory, ALWAYS GIVE THE MODEL, SPECIFICATION AND SERIAL NUMBER of the engine referred to.

Starting and Operating New Engines

Careful breaking-in of a new engine will greatly increase its life and result in trouble-free operation. A factory test is not sufficient to establish the polished bearing surfaces, which are so necessary to the proper performance and long life of an engine. These can only be obtained by running a new engine carefully and under reduced loads for a short time.

- Be sure the engine is filled to the proper level with a good quality engine oil.
- For proper procedures to follow when breaking-in a new engine, see 'Testing Rebuilt Engine'.

The various bearing surfaces in a new engine have not been glazed, as they will be with continued operation, and it is in this period of "running in" that special care must be exercised, otherwise the highly desired glaze will never be obtained. A new bearing surface that has once been damaged by carelessness will be ruined forever.

IMPORTANT SAFETY NOTICE

Proper repair is important to the safe and reliable operation of an engine. This Service Manual outlines basic recommended procedures, some of which require special tools, devices or work methods.

Improper repair procedures can be dangerous and could result in injury or death.

READ AND UNDERSTAND ALL SAFETY PRECAUTIONS AND WARNINGS BEFORE PERFORMING REPAIRS ON THIS ENGINE

Warning labels have also been put on the engines to provide instructions and identify specific hazards which if not heeded could cause bodily injury or death to you or other persons. These labels identify hazards which may not be apparent to a trained mechanic. There are many potential hazards for an untrained mechanic and there is no way to label the engine against all such hazards. These warnings in the Service Manual and on the engine are identified by this symbol:



Operations that may result only in engine damage are identified in the Service Manual by the word **CAUTION**.

Wisconsin Motors, LLC cannot anticipate every possible circumstance that might involve a potential hazard. The warnings in this manual are therefore not all inclusive. If a procedure, tool, device or work method not specifically recommended by Wisconsin Motors, LLC is used, you must satisfy yourself that it is safe for you and others. You should also ensure that the engine will not be damaged or made unsafe by the procedures you choose.

IMPORTANT the information, specifications and illustrations in this book are on the basis of information available at the time it was written. The specifications, torques, pressures of operation, measurements adjustments, illustrations and other items can change at any time. These changes can effect the service given to the product. Get the complete and most current information before you start any job. Continental Distributors/Dealers have the most current information which is available. For a list of current Distributors/Dealers, refer to directory LIT1017 or www.wiscosninmotors.com.



WARNING

Most sub-systems used in conjunction with Wisconsin Motors, LLC industrial engines including, but not limited to, radiators, hoses, fans fuel tanks, fuel lines or other fuel systems components, hydraulic pumps and generators, are not supplied by Wisconsin Motors, LLC, but are provided by the manufacturer of the end item in which the engine is used.

Some of the dangers associated with servicing such items are generally mentioned in this manual; however, the appropriate handbooks and safety instructions provided by the manufacturer of the end item should always be consulted prior to undertaking any work on sub-systems attached to the engine, to avoid any hazards inherent to these sub-systems.



WARNING

Read and observe all individual safety warnings as you use this manual to operate, service or repair your engine.

Always exercise caution whenever working with an engine or any associated system.

Injuries may be caused by lack of care when working with, or near, moving parts, hot parts, pressurized systems, electrical equipment, or fuel systems.

Always wear eye and hearing protection when working on or near engines.

Improper attire such as loose clothing, ties, rings, soft shoes or bare feet could be hazardous and should be avoided when servicing engines.

Use or service of the engine (including the use of modified parts or materials) not in accordance with manufacturer's specifications could damage your engine or cause personal injury.



WARNING

Starting fluids or aids such as ether or gasoline must not be used in a diesel engine air intake system. The use of these fluids will cause severe internal engine damage and/or bodily injury.



WARNING

Some equipment and materials used in the overhaul or maintenance of an engine such as machine tools, electrical equipment, compressed air, solvents, diesel, gasoline or other fuels may be dangerous and can cause injury. Always observe safety precautions associated with these items.

CONTENTS

CONTINENTAL INDUSTRIAL ENGINES

SECTION 1	
General Information	Page 5
SECTION 2	
Operating Instructions	Page 7
SECTION 3	
Lubrication	Page 13
SECTION 4	
Cooling System	Page 15
SECTION 5	
Fuel System	Page 21
SECTION 6	
Charging System	Page 32
SECTION 7	
Preventive Maintenance	Page 34
SECTION 8	
Engine Repair & Overhaul	Page 39
SECTION 9	
Trouble Shooting	Page 61
SECTION 10	
Torque Specifications	Page 67
SECTION 11	
Limits & Clearance Data	Page 69
INDEX	Page 71

Continental[®] Industrial Diesel

MODEL	TMD13		TMD20		TMD 27	
	METRIC	ENGLISH	METRIC	ENGLISH	METRIC	ENGLISH
No. of Cylinders	2	2	3	3	4	4
Bore & Stroke	91 x 103.2	(3.58 x 4.06)	91 x 103.2	(3.58 x 4.06)	91 x 103.2	(3.58 x 4.06)
Displacement	1.35 L	(82) CID	2.0 L	(123) CID	2.68 L	(164) CID
Compression Ratio	20.5:1	20.5:1	20.5:1	20.5:1	20.5:1	20.5:1
Max. Oil Pressure*	2.8 - 4.1 Bar	(40 - 60 PSI)	2.8 - 4.1 Bar	(40 - 60 PSI)	2.8 - 4.1 Bar	(40 - 60 PSI)
Min. Oil Pressure (Idling)	0.5 Bar	7 PSI	0.5 Bar	7 PSI	0.5 Bar	7 PSI
Firing Order	1-2	1-2	1-3-2	1-3-2	1-3-4-2	1-3-4-2
Main Brg. Frt.	73 x 23.8	(2.88 x .94)	73 x 23.8	(2.88 x .94)	73 x 23.8	(2.88 x .94)
Main Brg. Int.			73 x 23.8	(2.88 x .94)	(2)73 x 23.8	(2.88 x .94)
Main Brg. Thrust	73 x 31.8	(2.88 x 1.25)	73 x 31.8	(2.88 x 1.25)	73 x 31.8	(2.88 x 1.25)
Main Brg. Rear	73 x 23.8	(2.88 x .94)	73 x 23.8	(2.88 x .94)	73 x 23.8	(2.88 x .94)
Conn. Rod Brg.	49.2 x 24.5	(1.94 x .96)	49.2 x 24.5	(1.94 x .96)	49.2 x 24.5	(1.94 x .96)
Oil Capacity						
Crankcase	3.78 L	(4 Quarts)	4.73 L	(5 Quarts)	5.7 L	(6 Quarts)
Filter	.95 L	(1 Quart)	.95 L	(1 Quart)	.95 L	(1 Quart)
Total	4.73 L	(5 Quarts)	5.68 L	(6 Quarts)	6.65 L	(7 Quarts)
Valve Clearance						
Intake	.36	(.014)	.36	(.014)	.36	(.014)
Exhaust	.46	(.018)	.46	(.018)	.46	(.018)
Water Capacity						
Engine	2.0 L	(2.1 Quarts)	2.84 L	(3 Quarts)	3.6 L	(3.8 Quarts)
Weight (Approx.) (With Accessories)	191 Kg	(420 LBS.)	216 Kg	(475 LBS.)	253 Kg	(557 LBS.)

*Higher oil pressure may be experienced during cold starts.

INFORMATION FOR ORDERING PARTS

When ordering parts, refer to the engine name plate attached to side of the cylinder block, which lists the model and serial number. In most cases a

specification number is listed. This data is of vital importance in obtaining the correct parts: always include this information on your parts order.



Section 1 - General Information

CONTINENTAL DIESEL ENGINE

Continental Diesel Engines are Comet V combustion chamber indirect injection diesel engines.

The combustion chamber design has been tailored for the required turbulence, charge flow and burning characteristics to provide dependable and economical heavy duty service.

Some of the principal design features are:

1. **Individual Porting** — of the intake manifold whereby each cylinder is fed with the air charge individually and is not influenced by other cylinders of the engine.

This is accomplished by casting the cylinder head with individual intake valve passages for each cylinder and connecting these passages to an intake manifold which also has individualized passages for each cylinder.

2. **Water Jackets** — completely surround all cylinder bores to a depth sufficient to cover the hot piston ring travel, resulting in minimum bore distortion for good oil control yet maintaining low heat rejection to the coolant.

CHOICE OF FUELS — Continental Industrial Diesel Engines have been tailored for heavy duty operation for use with #1 or #2 diesel fuel that meet a minimum cetane number of 45 (see fuel recommendations, page 29).

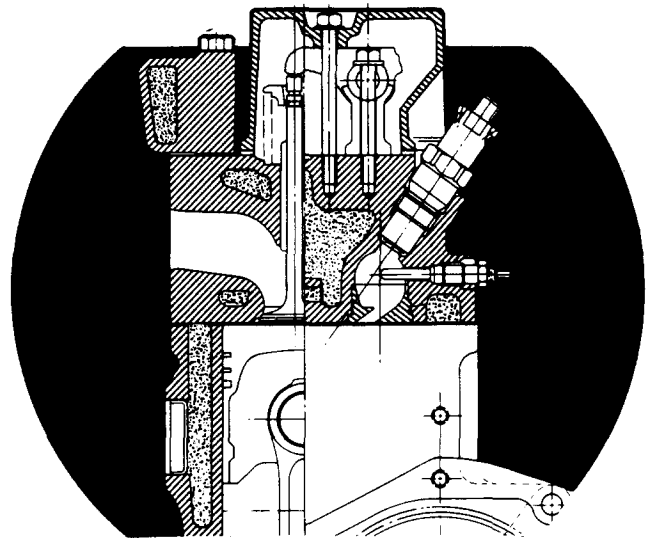

OHV Design

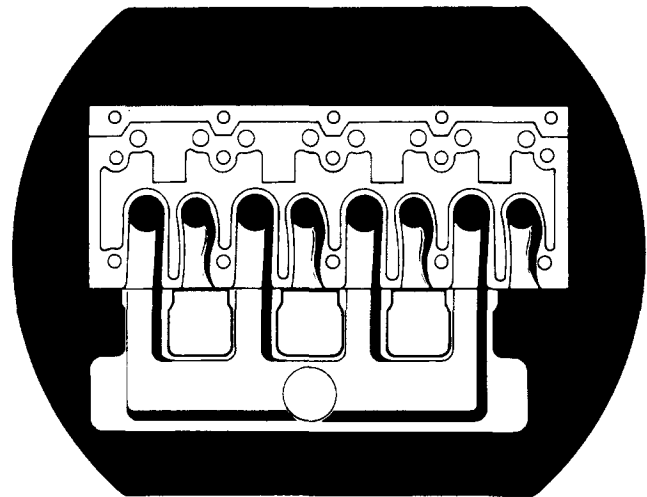

Individual Porting

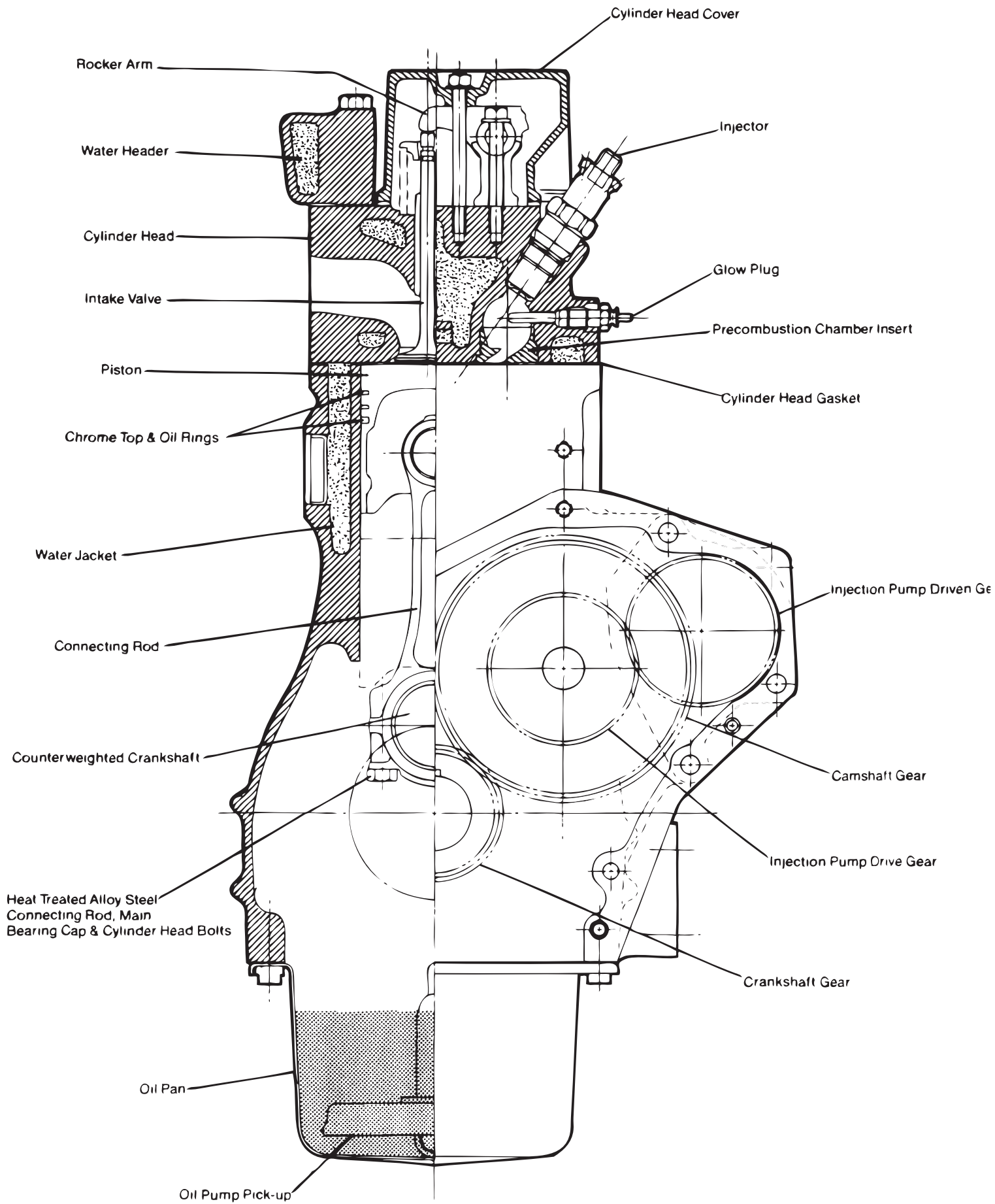

Cross section of typical
Continental Industrial Diesel

Section 2 - Operating Instructions

The person operating the engine naturally assumes responsibility for its care while it is being operated. This is a very important responsibility since the care and attention given the engine goes a long way in determining how long a period it will operate satisfactorily before having to be shut down for repairs.

The operating and preventive maintenance instructions for the Diesel Engines are simple and should be followed without deviation.

The entire aim in setting forth these instructions is to give you a benefit of the knowledge and experience gained over a long period of collaboration between Engineering Research and Field Service.

PREPARATION OF A NEW ENGINE FOR OPERATION

Before placing a new engine in operation, it must be thoroughly inspected for external damage and particular attention paid to the following items:

1. **Close water drain cock** — on the side of the block. (In some cases, this may be a pipe plug.)



Water Drain Cock

Fill radiator and water jacket with coolant. (See Cooling System Section 4).



Radiator Coolant Inlet

2. **Fill Crankcase with oil** — Use the oil recommended for the ambient temperature (see chart on page 14).

3. **Fill Fuel Tank** — See fuel recommendations on page 29.

WARNING

Stop engine before checking battery terminals or electrical connections. Sparks or flames near a battery could cause an explosion or fire. Battery acid can cause corrosive burns. Always wear eye protection. Use of jumper cables or battery charging should be done only as directed by manufacturers' safety instructions. Read and observe safety warnings on pages 1 and 2.

4. **Electrical Connections** — Check storage battery terminals and all electrical connections.

STARTING THE ENGINE

WARNING

Bodily injury or death may result to individuals during operation of an engine within any enclosure not adequately or properly ventilated. Engine operation in any enclosure requires adequate and proper ventilation to avoid asphyxiation or other interruption of normal breathing. To supply sufficient air to cool the engine, provide air to mix with fuel and to carry away heated air from the building. Read and observe safety warnings on pages 1 and 2.

If the engine is new or rebuilt or if fuel filters have been serviced or any low pressure lines disconnected, fuel system must be bled to remove any air that may have become trapped in the system.

Bleed the entire fuel system. Detailed instructions for bleeding the injection systems are given in section 5.

STARTING PROCEDURE

WARNING

Starting fluids or aids such as ether or gasoline must not be used in a diesel engine air intake system. The use of these fluids will cause severe internal engine damage and/or bodily injury. Read and observe safety warnings on pages 1 and 2.

1. **Disengage Power Take-Off** — (if equipped) Starting engine under load throws overload on starter and battery.

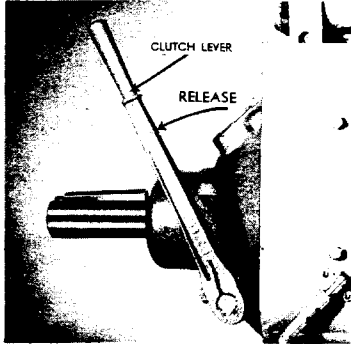

Power Take-off

2. Make sure electric shut-off is wired to permit fuel flow when the starter switch is in the "start" and "run" positions.
3. If the fuel pump is fitted with a mechanical shut-off, move the control to full open.
4. Engage glow plug preheat control and wait until the indicator light is off. If engine does not use an automatic preheat control, manually energize glow plugs for the appropriate time: either 7 seconds or 20 seconds depending upon which type glow plugs are used in the engine.
5. Move switch to start position and start engine.
6. Adjust throttle to idle at 800 to 1200 R.P.M. for a few minutes to circulate and warm the oil. Then open throttle to about half speed until the coolant reaches 38°C (100° F.).
7. If engine fails to start, turn switch to the "off" position and repeat the above steps. If starting is not attempted within 15 to 20 seconds, repeat the pre-heat sequence.
8. If engine still does not start refer to trouble shooting section 9.

9. Check Oil Pressure

MODEL	OIL PRESSURE*
TMD	2.8 - 4.1 Bar (40 - 60 PSI)

* Higher oil pressure may be experienced during cold starts.

10. Check Water Temperature

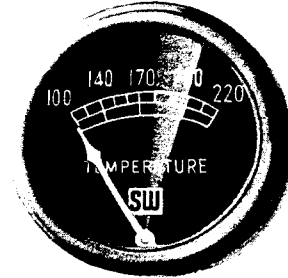

Water Temperature Gauge

11. **CAUTION:** After starting new engine — run it at idle for 5 minutes, then stop engine and recheck oil level in crankcase — then bring oil level to high mark on dipstick.

IMPORTANT! Breaking in a new or rebuilt engine — for peak performance and economical operation, the following adjustments should be made at end of first 50 hrs. operation.

1. Adjust valve tappets to specified clearances.
2. Adjust idle speed to equipment manufacturer's recommendation.

WARM UP NEW ENGINES

When new engines in distributors or dealers stock, showrooms, etc. are started up for any reason, they should be brought up to operating temperature in order to eliminate all condensation before stopping.

If they are stopped while still cold, condensation will settle on valve stems and guides, as well as other moving parts, and rust and sludge will form. Soon valves, rings, etc. will be stuck by this rusting and sludging action.

Engine should be operated long enough to bring oil and water temperature to normal operating temperature; be sure breather or ventilation system is open so vapor can be expelled.

STOPPING THE ENGINE

1. Disengage Power Take-Off

2. **Reduce engine Speed to Idle** — if hot, run engine at idle for several minutes to cool.

3. Move switch to off position.

4. If the fuel pump is fitted with a mechanical shut-off, move the control to full close.

11 "MUSTS" FOR YOUR ENGINES

1. **OIL PRESSURE** - should be up to recommended pressure at operating speed and over 0.5 Bar (7 PSI) at idle (800-1200 R.P.M.)

2. **AMMETER** - should register "Charging" at all times engine is running. (A voltage regulator may limit it to a very low reading).

3. **WATER TEMPERATURE** - normal operation 81°C - 96°C (178 - 205°F.). Higher temperatures are acceptable with pressurized systems. Overheating is detected by loss of coolant. "FREQUENT READINGS OF GAUGE SHOULD BECOME A HABIT".

4. **MUFFLER RESTRICTION** - should not exceed 508mm (20") water. Inspect mufflers periodically for restrictions to prevent burned valves.

5. **CLEAN AND SERVICE AIR CLEANER** - as recommended to maintain its efficiency.

6. **WHEN ENGINE IS OVERHEATED** - do not add water - allow engine to cool so as to prevent cracking the cylinder block, or cylinder head.

7. **AVOID COLD—SLUDGE CONDENSATION** - by protecting unit to maintain *crankcase* temperature over 57°C (135°F.). Use a proper temperature range thermostat and warm engine up thoroughly.

8. **BREAKING IN A NEW OR REBUILT ENGINE** - for peak performance and economical operation, the following adjustments should be made at end of first day's operation;

1. Adjust valve tappets to specified clearances.
2. Adjust idle speed to equipment manufacturer's recommendation.

9. **FOLLOW PREVENTIVE MAINTENANCE SCHEDULES RECOMMENDED** - this will avoid troubles which might cause expensive breakdowns and maintain your engine for dependable and economical operation.

10. **IDLING ENGINE** - slow engine down to low idle for about 5 minutes, after each operating period, before stopping - too rapid cooling down may cause distortion.

11. **CLEAN, WATER FREE FUEL** is vitally important to the operation of your engine and fuel injection system. Injection pump warranty will be affected if pump failure results from water in the fuel. When the presence of water in the fuel is suspected, the filter bowl should be drained daily until the amount of water so removed indicates that less frequent draining will be adequate to prevent water from entering the fuel injection pump. If more than a teacupful of water is drained off, the source of ingress must be found or else the filter bowl must be drained at more frequent intervals.

COLD WEATHER OPERATION

Battery condition is very important for proper starting.

The oil used during cold weather should have a cold test below the lowest anticipated temperatures that will be encountered during its use. The multigrade lubricating oils 5W-20 and 10W-30 are ideal for cold starting with its reduced initial drag until warmed up, when they assume the characteristics of the heavier oil.

Sludge formation at low temperatures is a close second to dirt in causing engine damage and

wear. This is formed by the piston combustion gases mixing with the fine oil mist in the crankcase and condensing on a cold surface. This condensation forms both a sulphuric and sulphurous acid which combines with the oil to become a highly injurious sludge. This dew point is about 57°C (135°F.) — when crankcase temperatures are higher, the contaminated gases remain in gaseous form and the engine operates clean as long as breather system is kept clean — however temperatures below this will

result in injurious sludge formation. It is vitally important therefore to maintain oil and crankcase temperatures above 57°C (135°F.) as shown on the following chart:

REACTIONS WITHIN ENGINE CRANKCASE TO TEMPERATURES DURING OPERATION

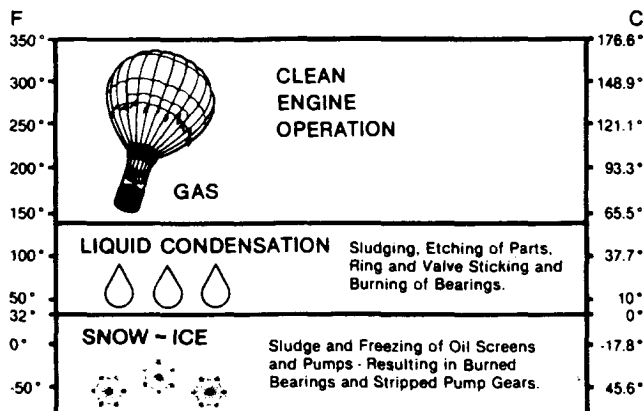

When sludging conditions prevail, the oil should be examined daily and changed as it may freeze, or clog the inlet strainer and cause bearing or oil pump failures.

High Altitude Operation—if engine is to be run continuously at a high altitude (above 5000 ft.) the pump calibration should be modified to maintain an acceptable smoke level. Contact manufacturer for recommendations.

Note: Some high altitude fuel delivery curve shaping can be performed on some STANADYNE fuel injection pumps in the field (see pg. 30).

High Temperature Operation—for every 5°C (10°F.) above 29.4°C (85°F.) inlet air temperature—a power loss of 1% results.

ENGINE PREPARATION FOR WINTER USE

More than 90% of the hard starting complaints in cold weather are the direct result of inadequate attention to preparation for winter use and proper maintenance. An engine not properly prepared requires more cranking energy and time, which puts a heavy load on batteries. So, invariably, batteries run down and the engine is blamed for hard starting. Putting your engine in proper condition and keeping it that way pays big dividends by reducing costly down time.

Use the checklist which follows to get your engine ready for winter. Then use the winter maintenance schedule to keep it in peak operating condition during the winter months.

CHECKLIST



WARNING

Stop engine before checking battery terminals or electrical connections. Sparks or flames near a battery could cause an explosion or fire. Battery acid can cause corrosive burns. Always wear eye protection. Use of jumper cables or battery charging should be done only as directed by manufacturers' safety instructions.

Read and observe safety warnings on pages 1 and 2.

1. ELECTRICAL SYSTEM

- Battery - replenish water and test for condition and state of charge. Replace if required.
- Wiring - check battery cables, connections and other wiring. Be sure connections are clean and tight and that cables and wiring insulation are in good condition.
- Alternator and regulator - run the engine and check the ammeter to be sure the alternator is charging and the regulator is functioning properly. Check and adjust alternator belt tension.

2. COOLING SYSTEM



WARNING

If the coolant is hot or if the engine has been running, loosen the pressure cap to the first stop and let the pressure out of the cooling system before removing the radiator cap.

Read and observe safety warnings on pages 1 and 2.

- Check radiator, hoses and engine for water leaks. Tighten hose clamps, repair leaks and install antifreeze to the level required for winter protection.

3. LUBRICATION SYSTEM

- Drain oil and change filter. Add oil of the proper winter grade.
- There are several different types and manufacturers of transmissions and power-take-offs. Caution should be used when determining the proper seasonal grade lubricant to assist in cold weather starting.

4. FUEL SYSTEM

- A. Check the fuel stop and throttle control for satisfactory operation and adjust as required.
- B. **Fuel filters** — must be checked more often, particularly the primary stage filter, to remove all the moisture and condensation separated from the fuel, otherwise this may freeze and stop the fuel flow.
- C. **Clean fuel** — handled by a reliable source having a cetane number of 45 minimum, is a definite requirement for easy starting and efficient operation. *We cannot caution you too seriously about obtaining fuel from a reliable source.*
- D. **Fuel recommendations** — the type of fuel to be used should be suitable for the ambient temperature to be expected. Refer to SAEJ313 or your local fuel distributor for detailed information (see page 30).

To insure against condensation in the fuel tank, fill to capacity at the end of each operating period.

5. EXHAUST SYSTEM

- A. Check the rain cap, if supplied, for proper operation and repair as required.

6. INTAKE AIR SYSTEM

- A. Be sure all hoses and clamps are properly seated and tight.
- B. Check instructions on the air cleaner decal. Service dry type air cleaner as specified.

7. MISCELLANEOUS

- A. Normal starting using the glow plugs supplied as standard equipment should be accomplished down to -20°C (-4°F). Contact Wisconsin Motors, LLC for special starting aids for colder temperatures.
- B. Check and adjust tappets.

WINTER MAINTENANCE

1. Perform maintenance in accordance with instruction manuals.
2. Change oil as recommended on page 14.

WARNING

Starting fluids or aids such as ether or gasoline must not be used in a diesel engine air intake system. The use of these fluids will cause severe internal engine damage and/or bodily injury. Read and observe safety warnings on pages 1 and 2.

3. If unit is only used for short periods and does not get thoroughly warm, operate it for at least an hour once a week to get it thoroughly warm. This will avoid excessive sludge in the oil and reduce dilution of oil with raw fuel in the crankcase.

PREPARATION OF ENGINE FOR SEASONAL STORAGE (90 DAYS TO 6 MONTHS)

1. **Run engine** — To thoroughly warm-up oil in crankcase.
2. **Stop engine** — And drain crankcase oil.
3. **Refill crankcase** — With SAE No. 10 engine preservative oil which meets MIL-L21260 Grade 1 specification.
4. **Fill cooling system** — With a solution containing a rust inhibitor.
5. **Drain fuel tank and filters** — Refill with about 2 gallons of a 50-50 mixture of pure white kerosene and SAE No. 10 engine oil.
6. Bleed the system as detailed in section 5.
7. Start engine and run it at half speed for 15 minutes when the oil will have circulated through the injection pump, lines and injectors.
8. Seal the air vent in the tank or filler cap with water-proofed adhesive tape.
9. Drain crankcase.
10. Drain cooling system completely.
11. **Clean exterior engine surfaces** — After engine has cooled; removing all grease or other foreign matter. Never wash a hot injection pump with cold water while engine is running.
12. **Seal all openings air-tight** — with adhesive tape that will not absorb or retain moisture.

Section 3 - Lubrication

ENGINE LUBRICATION SYSTEM

Continental industrial diesel engines have full pressure lubrication to all main, connecting rod and camshaft bearings as well as rocker arms and timing gears. Tappets are lubricated by overhead oil return.

OIL PUMP

On all engines, a large capacity gerotor type oil pump is driven off the crankshaft and protected by a screened inlet.

A by-pass valve maintains suitable oil pressure from idle to maximum speed automatically. Higher oil pressure may be experienced during cold starts.

Refer to page 4 for complete oil pressure figures.

CAUTION: If the oil pressure is erratic or falls below these limits, stop the engine IMMEDIATELY and find the cause of the trouble. Refer to trouble shooting section for this information.

A full flow oil filter is provided to remove dirt and foreign elements from the oil. The removal of grit, sludge and foreign particles causes filter elements to clog and become ineffective unless they are normally replaced every 100 hours or more often if conditions require.

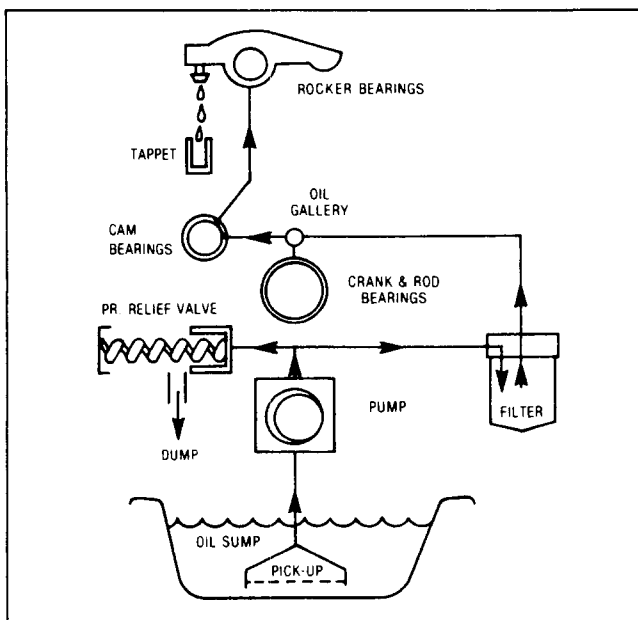

Full-Flow Filter System

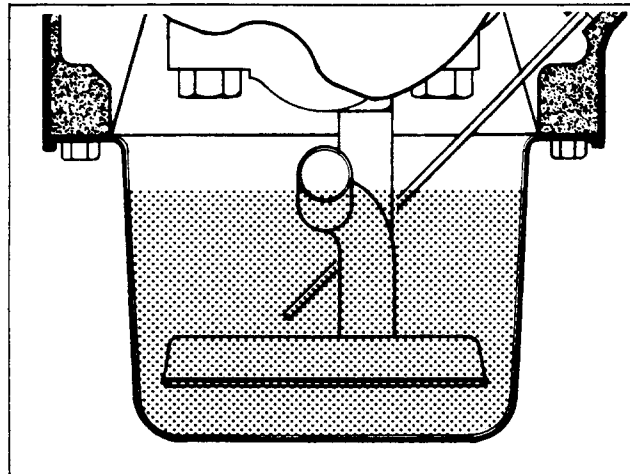

Oil Pump Pick-up (Typical)

OIL CHANGE FREQUENCY

Engine oil does not “wear out”. However, the lubricating oil in internal-combustion engines becomes contaminated from the by-products of combustion: dirt, water, unburned fuel entering the crankcase, and the detergents holding the carbon particles in suspension in the crankcase.

Note: On engines equipped with remote oil filters, always fill the oil filter element with motor oil prior to installation. Failure to do so may result in engine damage due to momentary oil starvation at start up.

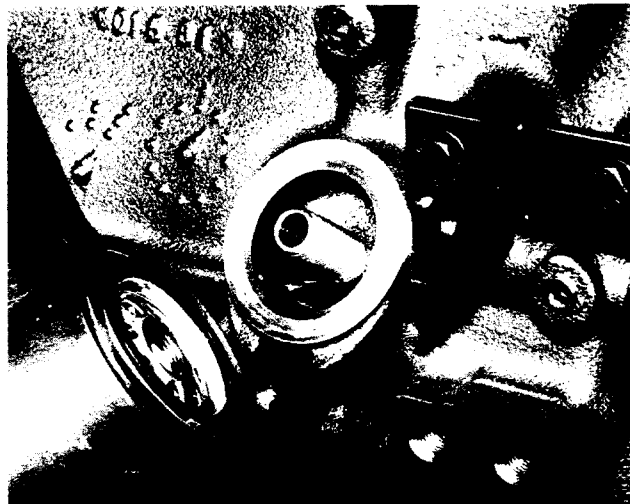

Oil Filter

The schedule for changing oil is directly dependent upon the operational environment: an extremely clean operation could go 100 hours while a dirty operation (foundry or cement factory) could be 50 hours or less. (See suggested oil and filter change intervals on page 14.)

LUBRICATION RECOMMENDATIONS

Motor oils used for internal-combustion engine lubrication perform many useful functions including: Dissipating heat, sealing piston rings, preventing metal-to-metal contact wear and reducing power loss through friction.

The lubricating oil recommendation is based upon engine design, type of service, and the atmospheric temperature prevailing. High quality oils are required to assure maximum performance, long engine life, and minimum cost of operation.

Continental industrial diesel engines operate in a wide range of service conditions and seasonal temperatures, so our recommendations are given for various types of service and ambient temperatures.

API SERVICE DESIGNATIONS

We recommend using oil described below for all Continental industrial diesel applications.

CD - Service Class D

Service typical of industrial diesel engines operating under engine manufacturer's warranties. High detergent - exceeds engine manufacturer warranty requirements.

- SE/CD** - Oil Classifications may be used.
- SF/CD** - Oil Classifications may be used.
- SG** - Oil Classifications may be used.

S.A.E. OIL BODY GRADES

The oil grades available from the lightest (SAE 5W) to the heaviest (SAE 50) are:

5W	10W	15W	20W	20	30	40	50
5W - 20					/		
/		10W - 30				/	
/			15W-50				

Multi-Grade Oils such as SAE 5W-20 and SAE 15W-50 have the starting grade characteristics of the lighter oil and after warm up have the running characteristics of the heavier grade.

The following SAE grades are general recommendations for Continental Industrial diesel engines during changing seasonal atmospheric temperatures:

AVERAGE AMBIENT TEMPERATURE AT WHICH ENGINE STARTING IS REQUIRED:							
*C	-30	-18	17	5	16	27	38 +
*F	-20	0	20	40	60	80	100 +
/						SAE 40	
/				SAE 30			
/			SAE 20W/20			/	
/		SAE 10W		/			
/			SAE 20W - 50			/	
/			SAE 20W - 40			/	
/			SAE 15W - 50			/	
/			SAE 15W - 40			/	
/		SAE 10W - 40				/	
/		SAE 10W - 30				/	
/		SAE 5W - 20					

For engines in continuous duty oil viscosity should be based on sump oil temperature.

Sump Oil Temperature	SAE Grade
210 - 250 *F (99 - 121 *C)	40 30
160 - 210 *F (71 - 99 *C)	30 10W - 30, 10W - 40 20W - 40, 15W - 40 20W - 50, 15W - 50
130 - 160 *F (55 - 71 *C)	20 10W - 30, 10W - 40

The Multi-Grade oil used should cover the single grade recommendation for the atmospheric temperature involved, e.g. SAE 10W-30 covers SAE-10W, SAE-20W, SAE 20 and SAE 30.

SUGGESTED OIL AND OIL FILTER CHANGE INTERVALS

Continuous Duty at Continuous Duty Rating		Light Duty Operation (25% Max. Continuous Rating) and Standby
CLEAN ENVIRONMENT	DIRTY ENVIRONMENT	
100 Hours Max.	50 Hours	200 Hours Max.

- NOTE:**
- Lube oil and filter must always be changed after the first 50 hours of operation of a new or rebuilt engine.
 - Environmental, installation, fuel system and general engine conditions can all influence lubricant performance. Lube oil analysis programs are recommended in all applications for optimum engine performance and life.

Standard Continental supplied starters and alternators have sealed bearings requiring no lubrication. Check your specification for accessories which may require periodic lubrication.

Section 4 - Cooling System

The function of the cooling system is to prevent the temperatures in the combustion chamber from damaging the engine and at the same time keep the operating temperatures within safe limits.

Maintaining the cooling system efficiency is important, as engine temperatures must be brought up to and maintained within satisfactory range for efficient operation; however, this system must be kept from overheating, in order to prevent damage to valves, pistons and bearings.

CAUTION: OVERHEATED ENGINE never pour cold water or cold anti-freeze into the radiator of an overheated engine. Allow the engine to cool and avoid the danger of cracking the cylinder head or block. Keep engine running while adding coolant.

COOLING SYSTEM

All Continental industrial diesel engines have the coolant force-circulated by a water pump and use a thermostat and by-pass system to control the temperature range.

The coolant from the pump enters the front of the block, passing along and between the cylinder bores and is metered by the head gasket into and across the cylinder head to cool the pre-combustion chambers, valve seats and guides.

Upon leaving the cylinder head, the coolant enters the thermostat housing, in which is mounted the positive shut-off thermostat, which controls the opening to the radiator or heat exchanger. Upon being discharged from the thermostat housing, the coolant enters the radiator or heat exchanger, depending upon the application, where it is cooled before re-entry into the engine.

Continental industrial diesel engines operate most efficiently with coolant temperatures of 81°-93°C (180°-200°F) and a thermostat and bypass system is used to control these temperatures.

The thermostat valve remains closed and only allows the coolant to circulate within the engine itself until normal operating temperatures are reached. This provides for both rapid and even temperature increase of all engine parts during the warm-up

period. When desired temperature is reached, the thermostat valve opens allowing all the coolant to circulate through both the engine and radiator, while shutting off the by-pass system.

IMPORTANT: Present thermostats begin to open at 81°C (180°F) and are fully open at 94°C (202°F). Operation of engines in this temperature range is not harmful. However, temperature gauges are not always accurate and may sometimes indicate higher than actual temperature. This can lead operators to believe engines are overheating when they are actually operating normally.

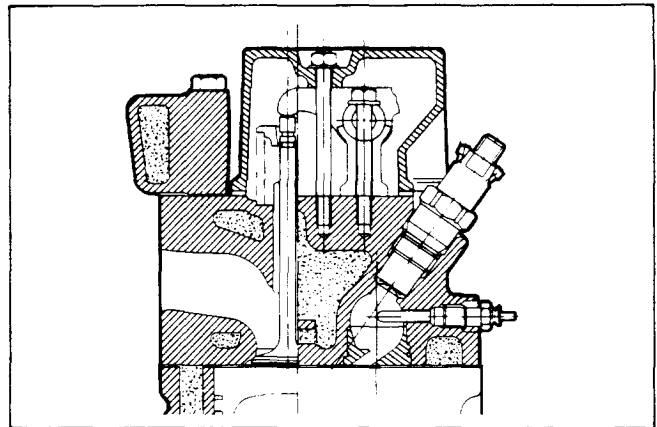

Sectional View showing Coolant Passages in Head and Block

EXPANSION OF WATER

Water has always been the most commonly used coolant for internal combustion engines because it has excellent heat transfer ability and is readily obtained everywhere. Like all liquids it expands when heated, the rate of expansion being 1/32 liter per liter (1/4 pint per gallon) when the temperature is raised from 4° to 81°C (40° to 180°F).

For example: If a 4 gallon cooling system is filled completely full of water at 4°C (40°F), 1 pint will be lost through the radiator overflow pipe by the time the water temperature reaches 81°C (180°F).

WATER FILTERS

In some areas, the chemical content of the water is such that even the best of rust inhibitors will not protect the cooling system from the formation of rust and scale.

There are instances where this corrosive element has eaten holes through cast iron parts such as water pump impellers and bodies. This condi-

tion is caused by electrolysis taking place in the parts involved.

Where these conditions exist, water filters should be incorporated in the assembly to remove these troublesome elements and offset the electrolytic action.

EFFECT OF ALTITUDE ON COOLING

Water boils at 100°C (212°F.) under atmospheric pressure at sea level. This pressure becomes less at higher altitudes and the reduced pressure causes water and other liquids to boil at a lower temperature.

ANTI-FREEZES

Water freezes at 0°C (32°F.), forms solid ice and expands about 9% in volume — which causes tremendous pressure and serious damage when allowed to freeze inside the cooling system.

When operating temperatures are below 0°C (32°F.) an anti-freeze liquid must be added which will lower the freezing point a safe margin below the anticipated temperature of outside air. Permanent anti-freeze will also raise the boiling temperature of the coolant.

The correct proportion of anti-freeze is also important when the engine is to be operated under high ambient temperature conditions.

ANTI-FREEZE	OPERATING TEMPERATURE RANGE		
	0° to -12°C (32° to 10°F.)	12°C to -23°C (+ 10° to -10°F.)	-23°C to -34°C (-10° to -30°F.)
ETHYLENE GLYCOL (permanent type) — When there are no leaks add water only to make up for evaporation.	Ratio Ethylene Glycol to water		
	1 to 4	2 to 5	1 to 1

CORROSION INHIBITORS

WARNING

Corrosion inhibitor can cause damage to the eyes or skin. If contact is made, immediately wash skin with water. For the eyes, immediately flush the eyes with water for several minutes. In either event, seek prompt medical attention.

Read and observe safety warnings on pages 1 and 2.

Water forms rust due to its natural tendency to combine chemically with iron and air in the system. Rust inhibitors for water are inexpensive, simple to use and make cleaning and flushing necessary only after long periods of operation.

The addition of a corrosion inhibitor is not necessary if an anti-freeze containing a rust inhibitor is used.

RADIATOR

The radiator or heat exchanger consists of a series of metal tubes through which the coolant is

circulated. In standard radiator design fins are connected to the metal tubes to give an extended surface through which heat can be dissipated. It is important that these tubes be kept clean on the inside and the fins free of dirt on the outside so the maximum heat transfer can take place in the radiator.

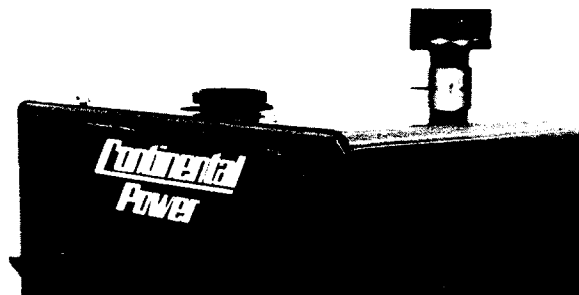

Radiator Coolant Inlet

Blowing out between the fins of the radiator, using compressed air, in a direction opposite to that of the fan circulated air, will serve to keep the cooling surfaces of the core free of dirt and other particles. Operating conditions will determine the frequency of this service.

Every 500 hours of operation the radiator and cooling system should be well cleaned and flushed with clean water.

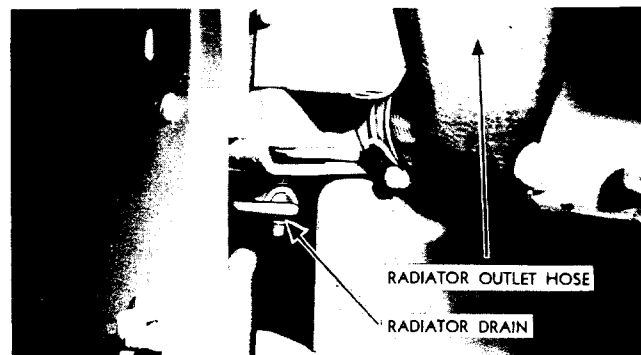

Radiator Drain

Wherever possible, only soft clean water should be used in the cooling system. Hard water will cause scale to form in the radiator and the engine water jackets and cause poor heat transfer. Where the use of hard water cannot be avoided an approved water softener can be used.

CLEANING COOLING SYSTEM

Deposits of sludge, scale and rust on the cooling surfaces prevent normal heat transfer from

the metal surfaces to the coolant and in time render the cooling system ineffective to properly maintain normal operating temperatures. The appearance of rust in the radiator or coolant is a warning that the corrosion inhibitor has lost its effectiveness and should be cleaned before adding fresh coolant.

Dependable cleaning compounds should be used. Follow the procedure recommended by the supplier. This is of prime importance because different cleaners vary in concentration and chemical compositions. After cleaning and flushing, the system should be filled with an approved anti-freeze compound containing a rust and corrosion inhibitor.

REVERSE FLOW FLUSHING

Whenever a cooling system is badly rustclogged as indicated by overflow loss or abnormally high operating temperatures, corrective cleaning by reverse flow flushing will most effectively remove the heavy deposits of sludge, rust and scale. The reverse flow flushing should be performed immediately after draining the cleaning solution. It is advisable to flush the radiator first, allowing the engine to cool as much as possible.

R v rse flush the radiator, as follows:

1. Disconnect the hoses at the engine.
2. Put radiator cap on tight.
3. Clamp the flushing gun in the lower hose with a hose clamp.
4. Turn on the water and let it fill the radiator.

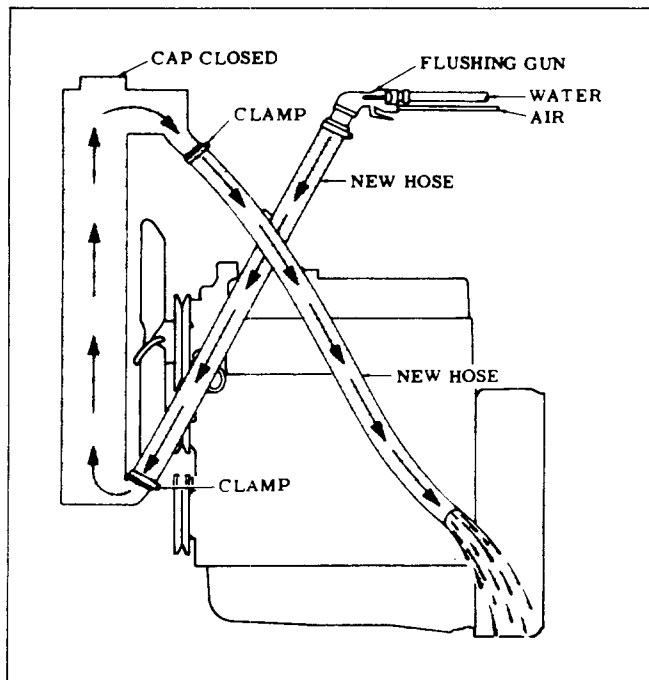

Reverse Flushing Radiator

5. Apply air pressure gradually, to avoid radiator damage.

6. Shut off the air, again fill the radiator with water and apply air pressure — repeat until the flushing stream runs out clear.

7. Clean and inspect radiator cap.

To Reverse flush the engine water Jacket

1. Remove the thermostat.
2. Clamp the flushing gun in the upper hose.
3. Partly close the water pump opening to fill the engine jacket with water before applying the air.
4. Follow the same procedure outlined above for the radiator by alternately filling the water jacket with water and blowing it out with air 5.5 Bar (80 PSI) until the flushing stream is clear.

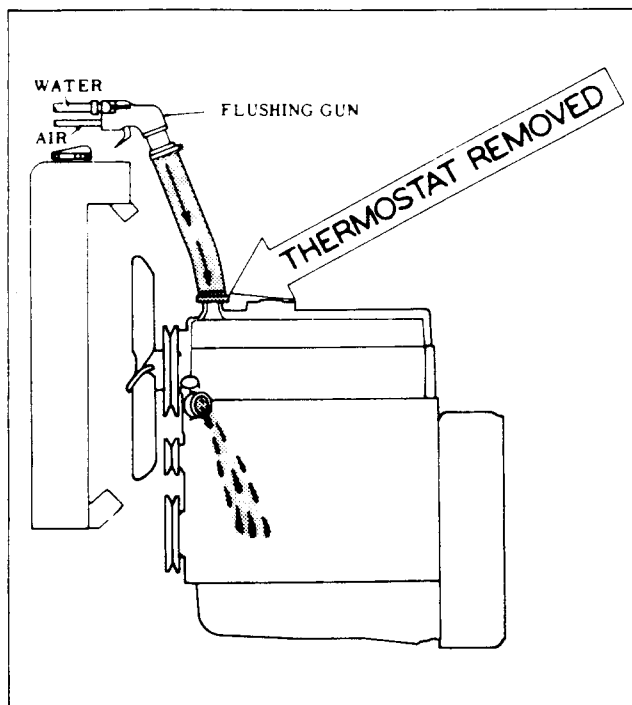

Reverse Flushing Engine

TESTING THERMOSTAT

Remove the water outlet elbow. Before testing, clean and examine the thermostat. If the valve can be pulled or pushed off its seat with only a slight effort when cold or it does not seat properly, the unit is defective and should be replaced.

Thermostat operation can be checked in the following method:

1. Hang thermostat by its frame in a container of water so that it does not touch the bottom.
2. Heat the water slowly and check temperature with a thermometer.

3. If the valve does not start to open at temperatures of 81° - 93°C (180° - 200°F.) or if it opens well before the 81°C (180°F.) point is reached, the thermostat should be replaced.

When replacing the thermostat in the water header be sure the counterbore is clean.

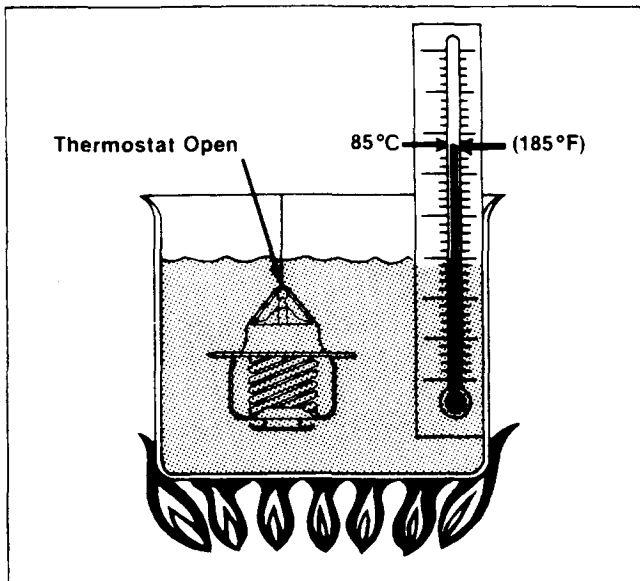

Checking Thermostat

When installing a new thermostat in the water header make sure that the temperature sensing unit goes in first or faces toward the cylinder head.



Installing Thermostat

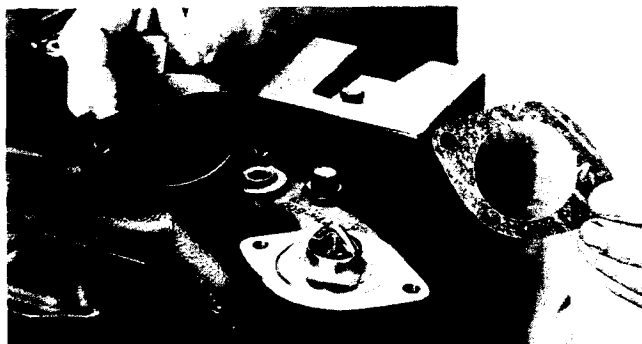

Installing New Gasket

Assemble new water outlet elbow mounting gasket. Thermostat flange must seat in counterbore with gasket sealing contact between it and the outlet elbow.

RADIATOR PRESSURE CAP

WARNING

If the coolant is hot or if the engine has been running, loosen the pressure cap to the first stop and let the pressure out of the cooling system before removing the radiator cap.

Read and observe safety warnings on pages 1 and 2.

Many operations use a pressure cap on the radiator to prevent overflow loss of coolant during normal operation. This spring loaded valve in the cap closes the outlet to the overflow pipe of the radiator and thus seals the system, so that pressure developing within the system raises the boiling point of the coolant and allows higher temperatures without overflow loss from boiling. Most pressure valves open at 0.3 or 1.0 Bar (4½ or 15 PSI), allowing steam and water to pass out the overflow pipe, however, the boiling point of the coolant at this pressure is 107°C (224°F.) or 120°C (248°F.) at sea level. When a pressure cap is used an air tight cooling system is necessary with particular attention to tight connections and a radiator designed to withstand the extra pressure.

PRESSURE CAP

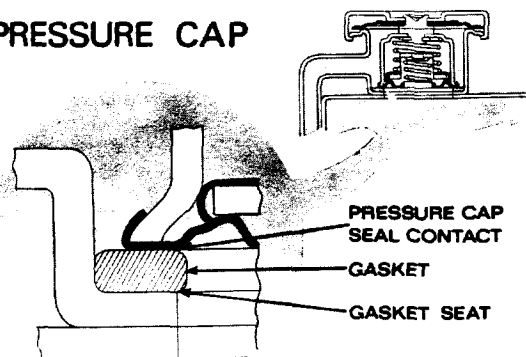

FAN BELT TENSION

When tightening fan belts, loosen the alternator adjusting bolts and pull out on the alternator by hand until the belt is just snug. Under no circumstances should a pry bar be used on the alternator to obtain fan belt tension or damage to the bearings will result.

When adjusted correctly the fan belt deflection on the long side should not exceed 13mm (1/2").

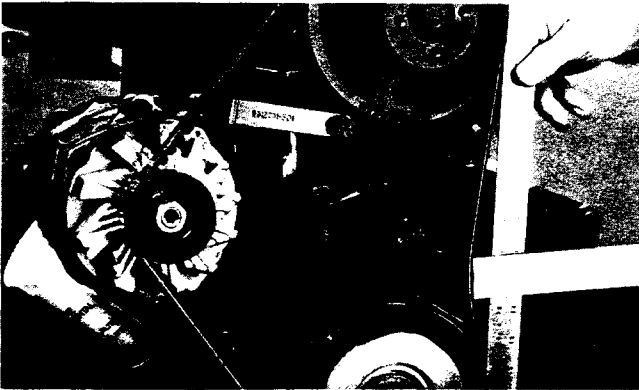

Adjusting Fan Belt Tension

CYLINDER BLOCK COOLANT DRAINS

When the cooling system is to be completely drained, there is a drain plug on the right hand side of the cylinder block which drains all coolant which might be trapped in the base of the block.



Coolant Drain

WATER PUMP

The water pump is located on the front of the cylinder block and is driven by the fan belt from the crankshaft pulley. The inlet of the water pump is connected to the lower radiator connection and the outlet flow from the pump is through integral passages cast in the block.

No lubrication of the pump is required as the bearings are of the permanently sealed type and are packed with special lubrication for the life of the bearing.

The water pump requires no attention other than bearing replacement when it shows excessive looseness or if a coolant leak develops which shows a damaged or badly worn seal that needs replacement.

REMOVING WATER PUMP

The water pump assembly can be removed from the engine as a unit for service or repair in the following manner:

1. Drain coolant.
2. Remove fan by taking out four cap screws.
3. Loosen alternator so that fan belt can be slacked off enough to slide over pulley.
4. Remove fasteners holding the pump body to the front of the block and remove the pump assembly.

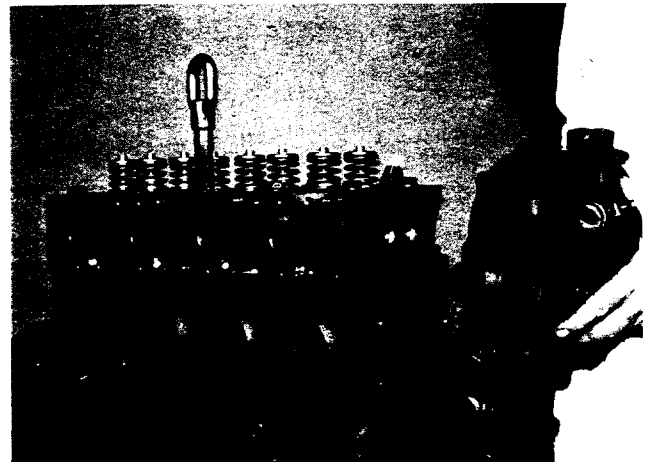

Removing Water Pump

DISASSEMBLY OF WATER PUMP

When replacement of any internal parts becomes necessary, disassembly must be in the following sequence in order to prevent damage to the pump.

1. Use puller to remove fan hub (11) from shaft.
2. Remove countersunk screws (1) holding cover (2) removing cover and gasket (3).
3. Use puller to remove impeller (4) taking precautions to prevent damage to the casting.
4. Remove seal (5).

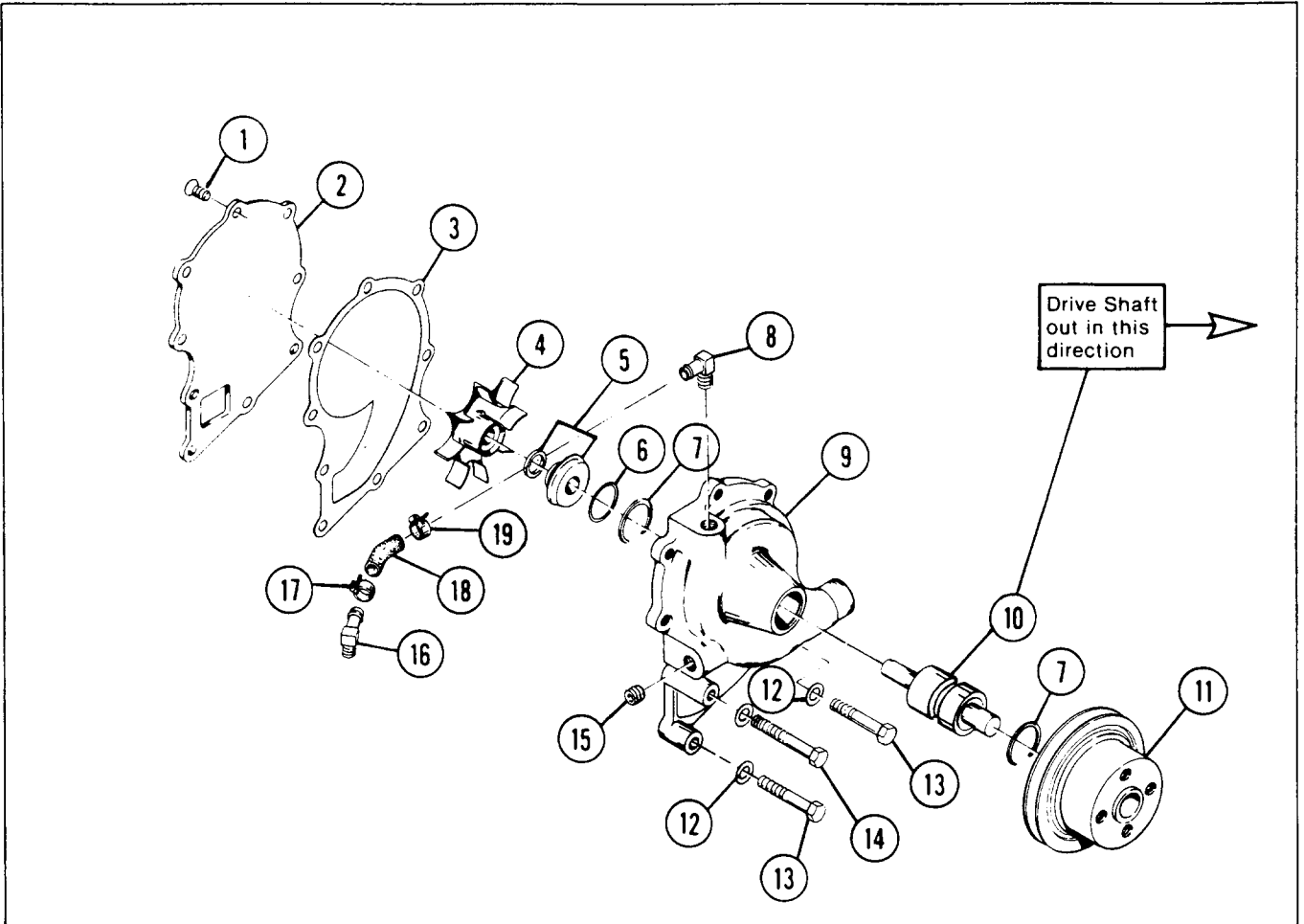

Disassembling Water Pump

5. Remove lock rings (7) holding bearing and shaft assembly in body after which shaft (10) can be forced out through the front with an arbor press or lead hammer. **DO NOT ATTEMPT TO DRIVE WATER PUMP SHAFT (10) OUT THROUGH REAR OF HOUSING.** To do so will damage the housing beyond repair.

REASSEMBLY AND INSTALLATION

1. Reassemble pump, replacing worn or failed parts.

Seal contact surfaces must be smooth and flat. The bushing should be replaced if scored or cut.

A light film of lubricant applied to the face of the seal will facilitate seating and sealing.

2. Use thick soapsuds on both the seal and shaft when assembling in order to prevent damage to the seal.

3. The fan hub must be installed prior to replacing rear plate. The shaft must be supported during this operation to prevent damage to the seal and bushing.

4. Mount pump assembly on block using a new housing gasket.

5. Install fan belt and adjust belt tension to have 13mm (1/2") deflection on long side.

Pull out the alternator by hand, as bearing damage will result with a pry bar.

6. Refill cooling system.

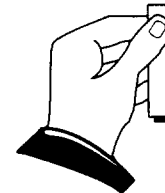

Please reference
SPB 88-374,
Clark Water Pump
Kits.

Section 5 - Fuel System

The basic purpose of the fuel system is to store, convey and inject the fuel into the engine.

The fuel transfer pump draws the fuel from the supply tank, forces it through the filters and delivers it to the injection pump. The fuel injection pump places it under the high pressure required for mechanical atomization, meters it with great accuracy, distributes it in the proper sequence to the various cylinders, commences the individual injections with fine precision in timing, and produces uniformly, through the nozzles, the correct pattern of spray for the combustion chamber.

The injection system of a diesel engine includes an injection pump assembly complete with governor, fuel supply pump, fuel filters, high-pressure steel lines connecting the pump discharge outlets to the nozzles, and nozzle holders and nozzle assemblies, one for each cylinder. Not the least of these are the filtration elements, as fine particles of dirt in the fuel are extremely destructive to high-pressure pumps of any description.

Careless or too frequent removal of elements of the fuel injection system for "inspection" or "cleaning" is generally far more harmful than beneficial, due to the danger that dirt will enter the exposed connections and the possibility of mishandling the equipment through lack of knowledge of its design and construction. Various components are made with the utmost precision and may be easily damaged when removed .

CAUTION: There should be no tampering with the injection pump assembly, or removal of it for inspection, unless engine operation is seriously impaired and the cause of the difficulty is directly traceable to the pump unit.

It should be borne in mind that minor troubles, such as suction leaks at joints in the supply line can cause erratic engine behavior. It is unlikely that the injection pump itself would require overhaul before it has several thousand hours of operation.

All injection pumps should be calibrated and repaired at authorized service stations, unless factory trained personnel are available with the proper tools and test equipment.

ELECTRIC FUEL TRANSFER PUMP

Many Continental TMD Industrial engines use

WARNING

Smoking or open flame should be avoided any time the fuel system is being repaired or serviced. The area should be properly ventilated. Improper handling of fuel could result in an explosion or fire causing bodily injury to yourself or others.

Read and observe safety warnings on pages 1 and 2.

electric fuel pumps to transfer fuel from the fuel tank to the fuel injection pump. These electric pumps are usually mounted to the crankcase fuel pump pad cover where a mechanical fuel pump would normally be mounted.

Electric fuel pumps will operate without having to crank the engine over. This makes them extremely useful when bleeding the air from the fuel system. (See **Bleeding the Fuel System.**) They draw little battery current and only a slight drain is usually seen on the storage battery during the bleeding process.

When fuel pump trouble is suspected - always check that the pump is getting voltage from the ignition circuit and that the BLACK ground wire is intact before declaring the pump is bad! A "quick" test for voltage is to turn the ignition switch "on" and feel the body of the pump. You can actually feel the pump operating and hear it ticking if the work area is quite enough. If you can't hear or feel the fuel pump operating - check for actual battery voltage to the unit before declaring it to be bad! Using a Voltmeter or test light - check for voltage at the first wire connection closest to the electric fuel pump. This connection is usually found at the fuel shut off solenoid on the fuel injection pump.

If no voltage is present - check the equipment electrical circuit for blown fuses; broken wires; bad switches; etc. If voltage is present at the fuel pump - make one last test before declaring the pump bad! Loosen the fuel line fitting on the inlet fuel line on the injection pump. Fuel should flow and the pump should begin ticking if it is operating properly.

If the pump is operating, but volume or flow needs to be checked - simply disconnect the fuel inlet line from the fuel injection pump and turn the ignition switch on. Be prepared, with a container, to catch the fuel as it comes out of the open line. A steady solid stream of fuel indicates that the fuel pump is probably OK for continued use. A broken stream with bubbles and dribbles or no fuel at all indicates the fuel pump is probably bad or that there are restrictions somewhere

in the fuel circuit. There could also be an air leak in the fuel pick up line on the suction side of the pump causing the pump to cavitate.

If restrictions are suspected in the fuel circuit, they are most likely found to be either plugged fuel filters or trash on the inlet side of the electric fuel pump.

BLEEDING THE FUEL SYSTEM

Bleeding is necessary on initial installation of the fuel injection system, after any subsequent removal, and if the system should be drained after having run out of fuel.

Note: Electrical equipment such as starters should be shielded with non-conductive material during the bleeding process to prevent damage from fuel entry. Also, be certain that all transmissions, gearboxes, hydraulic controls, etc. are in a neutral position before attempting to crank the engine. If a wheeled vehicle is involved - be certain that the wheels are "chocked" and the parking brake is set.

CAV-DPA Fuel System

Before bleeding and venting the CAV—DPA fuel system ensure that the outside of the vent screws and surrounding area is thoroughly clean to prevent dirt and foreign matter entering the system.

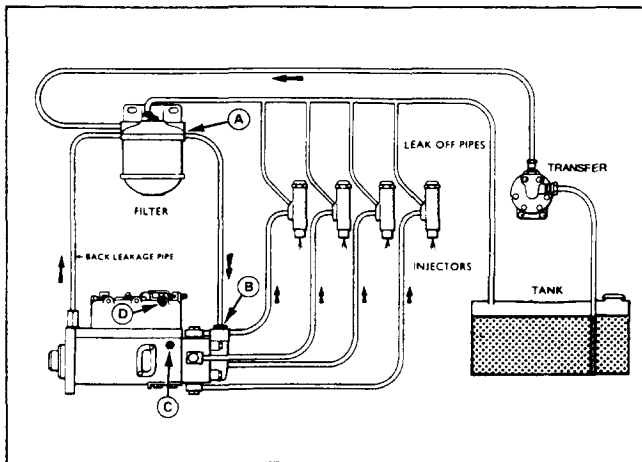

CAV—DPA Fuel System Schematic

Note: Electrical equipment such as starters should be shielded during bleeding to prevent fuel entry.

1. Turn the ignition switch to the "on" position.
2. Loosen the filter outlet (A), or the fuel injection pump inlet connection (B) whichever is the higher, and allow fuel to flow until free of air. Tighten connections.

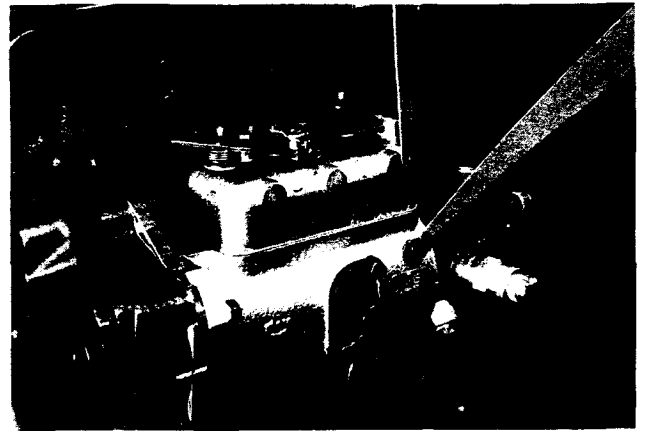

Injection Pump Vents (CAV—DPA)

Note: Filters of the four boss type must also be vented at the plugged boss; this must be done irrespective of the height of the filter in the system.

3. Loosen the vent valve fitted on one of the two hydraulic head locking screws (C), and the vent screw (D) on the governor housing. When fuel free from air flows from the vents, tighten the housing vent screw and then the governor vent screw.
4. Loosen any two injector high pressure pipe nuts at the injector end. Set the accelerator to the fully open position and ensure that the stop control is in the "run" position. Crank engine until fuel free from air flows. Tighten nuts.
5. **Energize the glow plugs.** (Refer to page 8.)
6. Start the engine.

Stanadyne Fuel System

1. Turn the ignition switch to the "on" position.
2. Loosen the filter outlet connection (A) or the fuel injection pump inlet connection (B) whichever is the higher and allow fuel to flow until free of air. Tighten the connection.

Note: If connection (A) is inaccessible due to the type of filter in use — loosen connection (B).

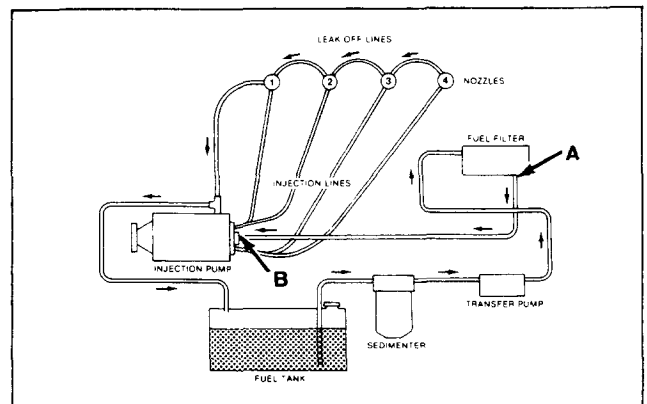

Typical STANADYNE Fuel System Schematic

3. Loosen any two injector high pressure pipe nuts at the injector end. Set the accelerator to the fully open position, and with the ignition switch "on", crank the engine until fuel free from air flows. Tighten the line nuts.
4. **Energize the glow plugs.** (Refer to page 8.)
5. Start the engine.

FUEL FILTERS

Clean Fuel is a Must in diesel operation. Extreme conditions may require additional filters to provide longer filter change periods - when clean fuel is not available.

Continental diesels are normally equipped with the filter installed between the fuel injection pump and the transfer pump outlet - so the filter is on the pressure side of the transfer pump.

The period for changing the element will largely depend upon the quality and condition of the fuel available. Under normal conditions the element should be renewed every 400 hours. This period should be decreased if unavoidable contamination of the fuel is experienced.

Not : Electrical equipment such as starters should be shielded with non-conductive material during filter replacing and priming to prevent fuel entry.

CAV-DPA Fuel Filter

The fuel filter is of the paper element type, and no attempt should be made to clean the element. It should be replaced when periodical maintenance is being carried out or if there is reason to believe that the element is plugged.

Under normal conditions, water should be drained from the fuel filter approximately once a week. Poor fuel quality and harsh work conditions can shorten the weekly drain interval to daily intervals.

To drain the water from the filter, simply loosen the drain plug at the bottom of the filter assembly 1/2 to 1 turn. Leave the drain plug open until water-free fuel is observed. Tighten the drain plug.

Not : It is best to drain the water after the engine has been at rest for awhile. This allows the water, which is heavier, to separate and settle to the bottom of the filter. Always drain the water from the fuel filter with the engine dead and electric fuel pump off.

To replace the filter element:

1. Remove filter bowl.
2. Discard the dirty element. Remove and discard the upper and lower element sealing washers and O-ring from the center stud.
3. Clean the inside of the bowl and center tube.
4. Fit the new upper and lower sealing washers. Install new O-ring on the center stud. Place the

new filter element in position and replace the bowl. Tighten center stud to 6-8 lb./ft. (8-11 Nm).
5. **Bleed the fuel system** (refer to page 22, CAV—DPA fuel system).

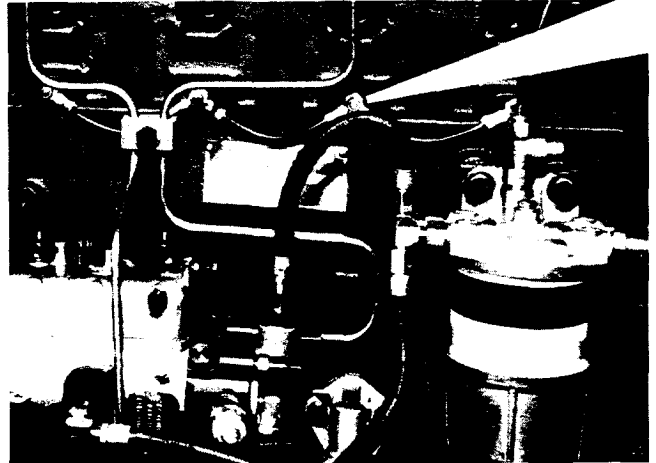

Glow Plugs

Stanadyne Fuel Filter

Note: This fuel filter is not a water separator. If water contamination is anticipated, an additional primary fuel filter and water separator should be installed before the fuel transfer pump.

No attempt should be made to clean this type element. It should be replaced at the regularly scheduled periodic maintenance interval or if there is reason to believe that it is plugged.

To replace the metal canister element simply release the two spring clamps and pull the old element off the filter bracket. Lube the new element grommets with clean diesel fuel and push into place. Snap the spring clamps into position and bleed the fuel system. (Reference page 23, Stanadyne Fuel System.)

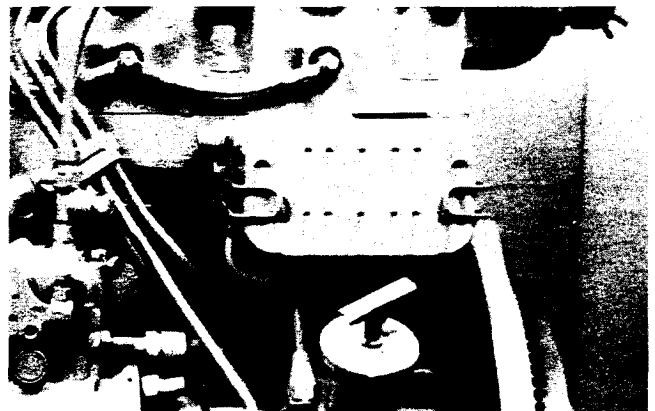

Stanadyne Fuel Filter (# TMD20F00400)

INJECTORS

When replacing injectors in the cylinder head it is essential that a new heat shield washer be fitted between the nozzle cap and the cylinder head. (Reference page 59, Heat Shield & Injector.)

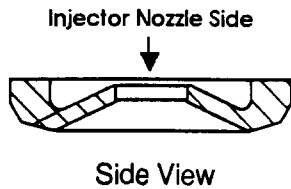

Tighten injectors evenly to 50-55 LB-FT (70 Nm). Injectors should be taken out only if engine is malfunctioning as outlined below:

1. Misfiring.
2. Knocking in one (or more) cylinders.
3. Engine overheating.
4. Loss of power.
5. Smoky exhaust (black or white).
6. Increased fuel consumption.
7. To perform a compression test.

The faulty injector or injectors may be located by loosening the line fitting nut on each, in turn, with the engine running at a fast idle. This allows the fuel to escape and not enter the cylinder. The injector least affecting the engine performance should be removed from the cylinder head and reconditioned or replaced.

CAUTION: No attempt should be made to adjust the injection pressure without a proper testing pump and pressure gauge. It is impossible to adjust the setting of the injector with any degree of accuracy without proper equipment. Therefore it is recommended that adjustments and/or repairs be made only by authorized CAV or Stanadyne repair centers, depending upon the type system involved.

TESTING

Injectors should not be disassembled unless testing shows that cleaning or other service is needed. Any disassembly of the fuel injectors should be done in an extremely clean work area. The exterior of the injectors should be rinsed with cleaning solution before testing. Be careful not to flush any debris into the open ports of the injector.

Before testing each injector, turn it upside down and shake it. This may get rid of any debris that has just entered the nozzle during the removal and cleaning process.

Use a special hydraulic injector tester equipped with a filter so that only clean oil enters the injector. There are many testers on the market—follow the

manufacturer's instructions for correct and safe operation of the test equipment chosen.

⚠ WARNING

Bodily injury may result during this operation if care is not exercised. The high velocity spray may puncture the skin and cause blood poisoning. Keep hands and face away from nozzle spray. Read and observe safety warnings on pages 1 and 2.

Before testing, determine the brand name of the fuel injector about to be tested. TMD engines currently use injectors made by two different companies. One company is CAV and the other is STANADYNE. They look very much alike, but are never mixed together on any one engine, because of different operating pressures.

The nozzles are identified by very small lettering on the outside of the nozzle as follows:

CAV—stamped just above the large hex portion of the nozzle.

STANADYNE—stamped just under one of the bleed off tubes.

After having identified the nozzle, connect it to the tester.

STEP 1: Set tester so that it will apply pressure and then work the pump handle several sharp strokes. This will dislodge some light carbon build-up from the tip of the nozzle and may remove any very fine dirt particles in the nozzle cavities.

STEP 2: Now work the pump handle slowly and observe the opening pressure. Compare to the following chart.

CAV	STANADYNE
Acceptable Pressure Limits * New Injector=1900-2016 PSI (131-139 BAR)	Acceptable Pressure Limits *New Injector=2150-2250 PSI (148.2-155.1 BAR)
**Service Injector=1755-2016 PSI (121-139 BAR)	**Service Injector=1925-2250 PSI (132.7-155.1 BAR)

*A new injector is an injector with no engine "run time" on it.
**A service injector is considered to be any injector that has been in use or any injector that has been reconditioned and no new parts were involved. The lower acceptable limit figures for the service injectors are necessary due to nozzle needle embedment and spring relaxation that takes place after a nozzle has been put into use.

Injectors that fail to meet the acceptable pressure limits should be adjusted by adding or subtracting

shims. Shims should be available from the CAV or STANADYNE service center which is performing the adjustment. Replace any injector that cannot be adjusted to meet the above pressure limit specifications.

Not : It is always a good practice to have all the injectors of any one engine set as nearly alike as possible. This makes for a smoother running engine.

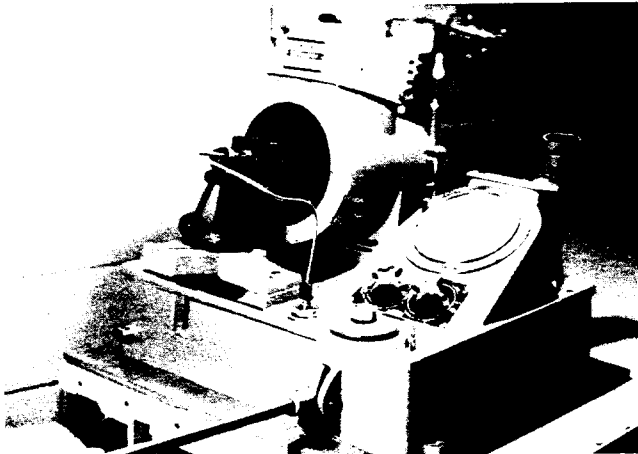

Checking Injector Opening Pressure

STEP 3: Once the pressure setting has been confirmed, check the nozzle spray pattern. Hold constant pressure on the tester lever to maintain the opening pressure of the nozzle. Watch for dribble from the spray orifice, which indicates a bad seat. Also, look for leaks along the body of the nozzle holder itself, which indicates a leak between the holder and the valve body lapped surfaces.

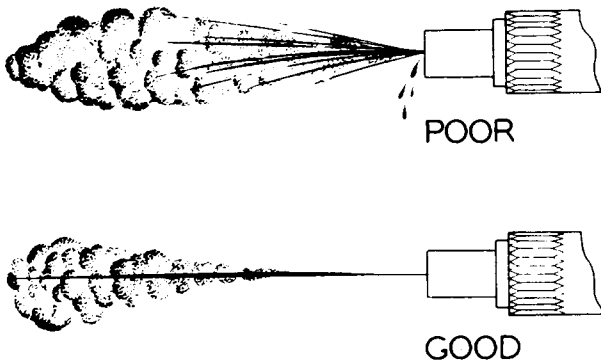

Nozzle Spray Patterns

STEP 4: Now work the pump handle rapidly (about 100 strokes per minute) and observe the spray pattern produced. Check that spray pattern is a "straight shot" or that it isn't aimed off to one side. The spray pattern should exit the injector in the form of a thin line stream that gradually gets a little wider before developing into a small mist cloud out at the end.

Wide or non-uniform spray patterns are questionable. If in doubt, the "judgement call" should be made

by the trained eye of the CAV or STANADYNE technician.

FUEL INJECTION PUMP

The function of a diesel fuel injection pump is to accurately meter and deliver fuel to a nozzle in each cylinder and to inject it at high pressure into the combustion chamber at precisely timed intervals. The extreme precision necessary can well be appreciated since this cycle must be repeated thousands of time per minute with virtually no variation in timing or amount of fuel injected.

Check the specification of your engine for your particular fuel injection pump.

Removal of the Fuel Injection Pump

Remove all high pressure fuel lines being careful not to bend them. Disconnect any low pressure fuel lines, linkage rods or electrical wires that need to come off to allow injection pump removal from the engine.

Remove the three long bolts that go completely through the timing gear cover and remove the injection pump. **DO NOT** separate the injection pump from the adaptor mounting plate unless absolutely necessary. This will save you much time during reinstallation of the pump if the pump is going back onto the same engine. (See Short Method pg. 26.)

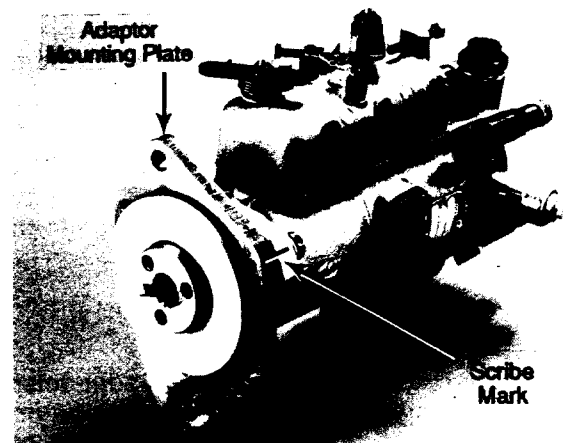

Typical CAV-DPA Fuel Injection Pump

CAV-DPA INJECTION PUMP

The DPA distributor type fuel injection pump, incorporating a sensitive all-speed governor, is a compact, self-contained unit for multi-cylinder diesel engines.

It is a relatively simple design, and incorporates no ball or roller bearings, gears or highly stressed springs. The number of working parts remains the same irrespective of the number of engine cylinders the pump is required to serve.

The pump is flange mounted to the engine. It is

oil-tight, and during operation all moving parts are lubricated by fuel oil under pressure, so that no additional lubrication system is required. Pressure maintained within the pump housing prevents the entrance of dust, water and other foreign matter.

Fuel injection is effected by a single element having twin opposed plungers located within a transverse bore in a central rotating member which acts as a distributor and revolves in a stationary member known as the hydraulic head. The pump plungers are actuated by lobes on an internal cam ring. Fuel is accurately metered to the pumping element, and the high pressure charges are distributed to the engine cylinders at the required timing intervals through ports in the rotor and the hydraulic head.

The integral governor is of the mechanical flyweight type, and gives accurate control of engine speed under all load conditions. Most pumps have an automatic device which varies the point of commencement of injection.

The single pumping element ensures uniform delivery of fuel to each engine cylinder, and eliminates having to balance the deliveries from each of the high-pressure delivery lines.

WORKING PRINCIPLE

The internal cam ring, mounted in the pump housing, normally has as many lobes as there are engine cylinders and operates the opposed pump plungers through cam rollers carried in shoes sliding in the rotor body. The plungers are forced inwards simultaneously as the rollers contact the diametrically opposed cam lobes. This is the injection stroke. The plungers are returned by pressure of the inflowing fuel and this forms the charging stroke.

The pump rotor is driven by the engine through a pinned hub and gear.

The accurate spacing of cam lobes and delivery ports ensures the exact equality of the timing interval between injections, and components which affect timing are designed with one assembly position only to ensure precision.

Fuel entering the pump through the main inlet connection is pressurized by a sliding vane transfer pump carried on the rotor inside the hydraulic head. The pressure rise is controlled by a regulating valve assembly located in the pump end plate. The fuel then flows through the passages to the pumping elements.

The outward travel of the opposed pumping plungers is determined by the quantity of fuel metered, which varies in accordance with the setting of the metering valve. In consequence, the rollers which operate the plungers do not follow the contour of the internal cam ring but contact the cam lobes at points which vary according to the degree of plunger displacement.

As the rotor turns, the inlet port is cut off and the single distributor port in the rotor registers with an outlet port in the hydraulic head. At the same time the

plungers are forced inwards by the rollers contacting the cam lobes, and fuel under injection pressure passes up the central bore of the rotor through the aligned ports to one of the injectors. The rotor normally has as many inlet ports as the engine has cylinders, and a similar number of outlet ports in the hydraulic head.

The cam lobes are contoured to provide relief of pressure in the injector lines at the end of the injection cycle; this gives a sharp cut-off of fuel and prevents "dribble" at the nozzles.

The governor flyweight assembly is mounted on the drive shaft and is contained entirely within the pump body. Linkage transmits the movement of the governor flyweights to the control lever on the metering valve. The governor control mechanism is enclosed in a housing mounted on the pump body.

OVERHAUL PROCEDURE

Dismantling, assembly, testing and adjustment of the DPA pump must be carried out by trained personnel, using specialized tools and test apparatus.

Contact your Continental distributor for details.

TIMING OF INJECTION PUMP TO THE ENGINE

WARNING

Bodily injury may result during the timing operation of the fuel injection pump if the engine is running. **DO NOT** attempt to adjust the timing without the pump mounting bolts securely torqued.

Injection pumps must be installed on the engine in accurate alignment and timed to correct relation with the crankshaft for proper engine operation with maximum power and economy and to prevent complaints of hard starting, overheating, uneven running and excessive smoking.

Installation procedures and timing methods will vary depending on the make and model of the Fuel Injection Pump in use. The TMD engine is equipped with either a CAV-LUCAS injection pump or a STANADYNE injection pump. Be sure of the kind of pump involved before attempting the installation and timing procedures that follow. Look for nameplates or raised letters on the body of the pump for identification purposes. If identification of the pump is difficult, call your local distributor for assistance. Be sure to have the engine model number, specification number and serial number available when you call.

The installation and timing procedure for the fuel injection pump will be separated into a **Short Method** and a **Long Method**.

The **Long Method** must be used any time a new or reconditioned injection pump is involved or any time a new or other than original adaptor mounting plate is used. Also, any time an injection pump is transferred from one engine to another.

The **Short Method** is used only when the original injection pump, adaptor mounting plate and crankcase are assembled together. If an injection pump has been tested, but no repairs were necessary, it can be reinstalled using the Short Method. However, if repairs are necessary to the fuel injection pump, it is now considered to be "reconditioned" and the Long Method must be used.

Short Method - CAV

The following steps are for reinstalling and timing the original Fuel Injection Pump and Adaptor Plate onto the engine from which it was removed:

1. Install a new O ring (P/N X07837) into the groove on the adaptor mounting plate.
2. Lightly lubricate the O ring with motor oil.
3. Rotate the crankshaft pulley clockwise (viewed from the front) until the #1 piston is at TOP DEAD CENTER (TDC) on the COMPRESSION stroke.

TDC is when the notch on the front pulley lines up with the DC mark on the pointer plate.

Not : Some engines have DC marks on the flywheel and a pointer pin fixed into the bell housing. Usually these are hidden by an access cover.

The COMPRESSION stroke is determined by looking for the single beveled tooth on the rear side of the injection pump drive gear while the engine is at TDC. The injection pump drive gear is the smaller of the two gears visible in the opening where the injection pump mounts to the engine. If the beveled tooth is not visible in the opening, simply rotate the crankshaft pulley one complete revolution clockwise and check for the beveled tooth again.

This is very important, because this engine will run with the injection pump installed 180° out of time. However, it runs very poorly in that condition.

4. Remove the screw plug and washer located on the front side of the timing gear cover. It is positioned directly in front of the injection pump gear.
5. Find a piece of round stock approximately 1/4" in diameter and 5" to 6" long. Welding rod or brazing rod minus the flux works good here.
6. Insert the 1/4" round stock through the gear cover and into the .236" (6mm) dead end hole in the injection pump gear.
7. Guide the injection pump into position and install the three long M10 mounting bolts, lock washers and nuts that secure the adaptor

mounting plate to the engine.

8. Torque the long M10 mounting bolts to 25-30 FT. LBS. (34-40 Nm).

9. Check that the scribe mark on the injection pump flange is matched up with the scribe mark on the injection pump adaptor mounting plate. The two marks should look "as one" when the job is complete.

10. Check that the three M8 bolts that fasten the injection pump to the adapter mounting plate are tight at 15-18 FT. LBS. (20-24 Nm).

Note: Steps 9 and 10 may be unnecessary if the injection pump was never loosened from or separated from the adapter mounting plate during removal of the pump from the engine.

11. Remove the 1/4" round stock from the gear cover and re-install the screw plug and washer.

12. Install the high pressure fuel lines and torque the fuel line nuts to 20-25 FT. LBS. (27-34 Nm).

Note: Leave any two of the injector line nuts loose at the nozzles which is part of Bleeding the Fuel system (see page 22).

13. Re-connect all electrical wires, linkage rods, low pressure fuel lines, shut down cables, etc.

14. Bleed the fuel system (see page 22).

Long Method - CAV

The following steps are for installing and timing a new or reconditioned or other than original Fuel Injection Pump:

1. Grind or file off any existing scribe mark that may be on the injection pump adaptor mounting plate. A new plate will have no scribe mark.

2. Install a new gasket to the front of the injection pump. (Gasket P/N TMD27B00300)

3. Install the adapter mounting plate onto the injection pump using the M8 screws, flat washers, and lock washers. Tighten screws finger tight.

4. Install the injection pump gear along with alignment dowel pin onto the injection pump shaft. Use three M8 screws (P/N X22132) and lock washers for mounting the gear.

5. Hold the gear in a soft jawed vise and torque the three M8 screws to 20-25 FT. LBS. (27-34 Nm).

6. Install a new O ring (P/N X07837) into the groove on the adapter mounting plate.

7. Lightly lubricate the O ring with motor oil.

8. Rotate the crankshaft pulley clockwise (viewed from the front) until the notch on the pulley is at the 19°-20° degree Before Top Dead Center (BTDC) mark on the pointer plate.

Not : Some engines use marks on the flywheel and a pointer pin fixed into the bell housing. If this is the case, be certain that you are working with the BTDC marks. Bell housing pointers are usually hidden by an access cover.

9. Check that the engine is on the compression stroke by looking for the single beveled tooth on the rear side of the injection pump drive gear. The injection pump drive gear is the smaller of the two gears visible in the opening where the injection pump mounts to the engine.

If the beveled tooth is not visible in the opening, simply rotate the crankshaft clockwise one revolution and it will be visible.

This is very important, because this engine will run with the injection pump installed 180° out of time. However, it runs very poorly in that condition.

10. Remove the timing hole cover from the side of the injection pump housing. Turn the injection pump gear until line "A" on the rotating shaft lines up with the flat end of the snap ring (see below).

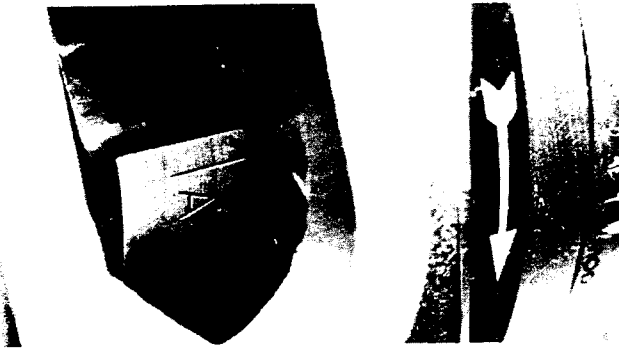

Injection Pump Timing Mark

11. Guide the injection pump into position and install the three long M10 mounting bolts, lock washers and nuts that secure the adaptor mounting plate to the engine. Torque the M10 bolts to 25-30 FT. LBS. (34-40 Nm).

12. Check that line "A" is still lined up with the flat end of the snap ring. If it isn't, rotate the body of the injection pump until it is.

13. Torque the three M8 bolts that fasten the injection pump to the adaptor mounting plate to 15-18 FT. LBS. (20-24 Nm).

14. Rotate the crankshaft counter clockwise about 1/4 turn (viewed from the front). Then rotate clockwise, stopping at 19°-20° BTDC. Re-check that line "A" is still lined up with flat end of snap ring. If not, reset.

15. Install the timing hole cover onto the injection pump housing.

16. Install the high pressure fuel lines and torque the fuel line nuts to 20-25 FT. LBS. (27-34 Nm).

Note: Leave any two of the injector line nuts loose at the nozzles which is part of Bleeding the Fuel System (see page 22).

17. Re-connect all electrical wires, linkage rods, low pressure fuel lines, shut down cables, etc.

18. Bleed the fuel system (see page 22).

19. Restamp the pump to adaptor mounting plate scribe marks.

WARNING

Bodily injury may result during the timing operation of the fuel injection pump if the engine is running. **DO NOT** attempt to adjust the timing without the pump mounting bolts securely torqued.

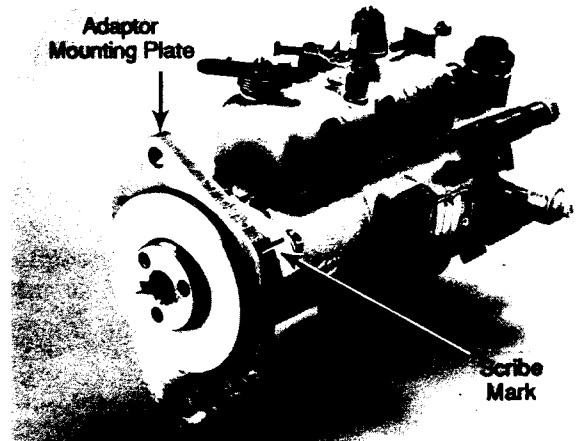

Typical CAV-DPA Fuel Injection Pump

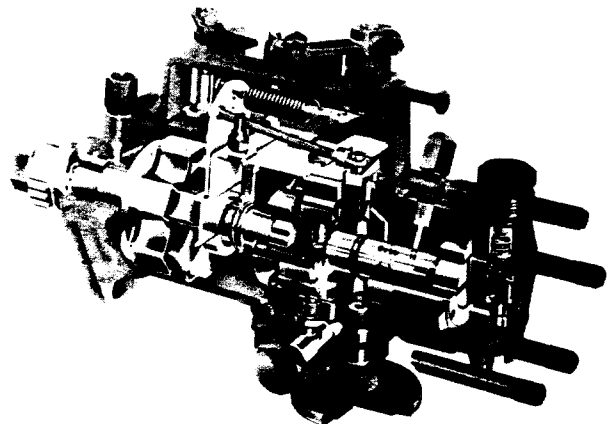

Typical CAV-DPA Fuel Injection Pump (cut-a-way)

STANADYNE MODEL DB2 INJECTION PUMP

The model DB2 injection pump is described as an opposed plunger, inlet metered, positive displacement, distributor type pump. The DB2 pump incorporates a single pumping chamber.

Precise distribution between cylinders, inherent in the pump design, and the ability to preset fuel flow eliminates lengthy periods on the test stand. The pump is self-lubricated, contains essentially the same number of parts regardless of the number of cylinders served.

Working Principle

The main rotating components are the drive shaft, transfer pump blades, distributor rotor, and governor.

The drive shaft engages the distributor rotor in the hydraulic head. The drive end of the DB2 rotor incorporates two pumping plungers.

The plungers are actuated toward each other simultaneously by an internal cam ring through rollers and shoes which are carried in slots at the drive end of the rotor. The number of cam lobes normally equals the number of engine cylinders.

The transfer pump at the rear of the rotor is of the positive displacement vane type and is enclosed in the end cap. The end cap also houses the fuel inlet strainer and transfer pump pressure regulator. The face of the regulator assembly is compressed against the liner and distributor rotor and forms an end seal for the transfer pump. The injection pump is designed so that end thrust is against the face of the transfer pump pressure regulator. The distributor rotor incorporates two charging ports and a single axial bore with one discharge port to service all head outlets to the injection lines.

The hydraulic head contains the bore in which the rotor revolves, the metering valve bore, the charging ports and the head discharge fittings. The high pressure injection lines to the nozzles are fastened to these discharge fittings.

The DB2 pump contains its own mechanical governor, capable of close speed regulation, the centrifugal force of the weights in their retainer is transmitted through a sleeve to the governor arm and through a positive linkage to the metering valve. The metering valve can be closed to shut off fuel through solid linkage by an independently operated shut-off lever, or by an electrical solenoid.

The automatic advance is a hydraulic mechanism which advances or retards the pumping cycle.

Note: There are various types of STANADYNE fuel injection pumps used on the TMD engine. They are used in the 2 cylinder, 3 cylinder and 4 cylinder engine models. Various equipment applications having different speed ranges and load ranges are involved. As a result, there are numerous injection pump timing settings required to cover the many STANADYNE applications. To determine the correct injection pump timing for your particular engine, refer to Service Parts Bulletin 92-420.

Short Method - STANADYNE

—Re-installing and timing the original Fuel Injection Pump and adaptor plate onto the engine from which it was removed.

This method is identical to the STANADYNE Long Method that follows except that you omit the first (5) five steps when performing the Short Method.

Note: There is a chisel type scribe mark that is stamped into the injection pump mounting flange and the adaptor mounting plate. In most cases, at the end of Step 15, these two marks will line up. However, don't be alarmed if they miss lining up by a small distance.

The most important point about timing the STANADYNE injection pump is the alignment of the **internal** timing marks (Ref. Step 15) and the corresponding location of the front pulley timing mark (Flywheel timing mark on some engines). See SPB 92-420 for the timing setting required on your particular engine.

Long Method - STANADYNE

—Installing and Timing a New or Reconditioned or other than original Fuel Injection Pump.

WARNING

Bodily injury may result during the timing operation of the fuel injection pump if the engine is running. DO NOT attempt to adjust the timing without the pump mounting bolts securely torqued.

1. Grind or file off any existing scribe mark that may be on the injection pump adaptor mounting plate. A new plate will have no scribe mark.
2. Install a new gasket (P/N TMD27B00300) to the front of the injection pump.
3. Install the adaptor mounting plate onto the injection pump using the M8 screws, flat washers and lock washers. Tighten screws finger tight.
4. Install the injection pump gear along with alignment dowel pin onto the injection pump shaft. Use three M8 screws (P/N X22132) and lock-washers for mounting the gear.
5. Hold the gear in a soft jawed vise and torque the three M8 screws to 20-25 FT. LBS. (27-34 Nm).
6. Install a new O ring (P/N X07837) into the groove on the adaptor mounting plate.
7. Lightly lubricate the O ring with motor oil.
8. Rotate the crankshaft pulley clockwise (viewed from the front) until the notch on the pulley is at the timing setting prescribed in SPB 92-420.

Note: Some engines use marks on the flywheel and a pointer pin fixed into the bell housing. If this is the case, be certain that you are working with the correct set of marks. Bell housing pointers are usually hidden by an access cover.

9. Check that the engine is on the compression

stroke by looking for the single beveled tooth on the rear side of the injection pump drive gear, the injection pump drive gear is the smaller of the two gears visible in the opening where the injection pump mounts to the engine.

If the beveled tooth is not visible in the opening simply rotate the crankshaft one revolution clockwise and it will be.

This is very important because this engine will run with the injection pump installed 180° out of time. However, it runs very poorly in that condition.

10. Remove the timing hole cover from the side of the injection pump housing.

11. Turn the injection pump gear until the internal timing marks are lined up. (See Below).

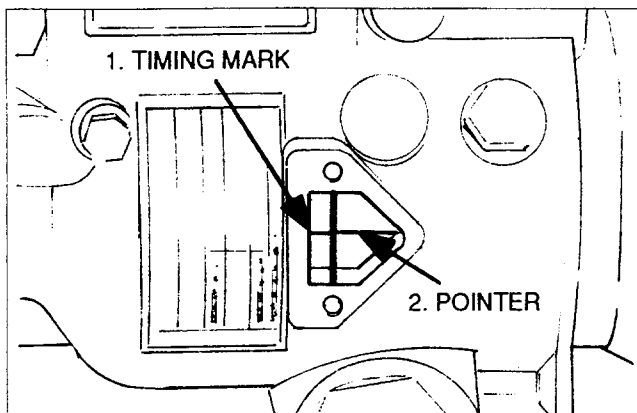

Turn the injection pump gear until timing mark is aligned with the pointer.

12. Guide the injection pump into position and install the three long M10 mounting bolts, lock washers and nuts that secure the adaptor mounting plate to the engine. Torque the M10 bolts to 25-30 ft. lbs. (34-40 Nm).
13. Inspect the internal timing marks again. The two marks should look like one unbroken horizontal line. If not, you must judge as to whether the pump gear is one tooth or more out of time or if a minor rotation of the injection pump body will align the marks.

If the marks are far apart, repeat step 12, because the pump gear is probably out of time. If the marks are very close together, rotate the body of the injection pump one way or the other until the marks line up.

14. Torque the three M8 bolts that fasten the injection pump to the adaptor plate to 15-18 ft. lbs. (20-24 Nm).

15. Re-check the timing marks after eliminating the backlash and play that may be in the timing gear train. This is done by rotating the crank pulley counter clockwise approximately 1/4 turn (viewed from the front). Then rotate the crank pulley clockwise until it is back to the prescribed timing position. Check the internal timing marks once again and adjust if needed.

16. Install the timing hole cover and gasket onto the injection pump housing.

17. Install the high pressure fuel lines and torque the fuel line nuts to 20-25 ft. lbs. (27-34 Nm).

Not : Leave any two of the fuel line nuts loose at the nozzles which is part of Bleeding the Fuel System. (See Page 23).

18. Re-connect all electrical wires; linkage rods; low

pressure fuel lines, etc.

19. Bleed the fuel system. (See Page 23).

Overhaul Procedure

Dismantling, assembly, testing and adjustment of the DB2 pump must be carried out by trained personnel, using specialized tools and test apparatus.

STANADYNE DB2 INJECTION PUMP

Welder or Generator Set Governor

Normally, the DB2 can produce stable governing at 3% regulation for welder or generator sets. This can be obtained at either 1500 (50 Hertz) or 1800 RPM (60 Hertz). The speed droop control is used where the regulation is adjusted while the generator set is operating. The external control knob with an internal screw thread pitch similar to the governor spring pitch is adjusted to add or subtract active coils, as shown.

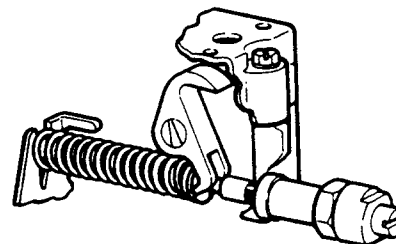

Speed droop governor control

Only minor throttle lever trimming is necessary. Thus a single spring may allow a droop adjustment of approximately 2 to 5%. A single governor spring may also be selected which will regulate this droop adjustment range at both 1500 and 1800 RPM. The inherent self governing feature of inlet metering is especially advantageous for such close governing control. This is further aided by the extremely low masses and resulting inertia forces of the metering valve and governor components. During initial set-up of a welder or generator set, the speed droop control must be adjusted to provide the sharpest regulation possible without surge or combustion instability. Turning the speed droop screw clockwise broadens regulation and reduces instability.

After the proper droop setting is achieved, high idle must be readjusted.

Fuel Delivery Curve Shaping for High Altitude use on Welder and Generator Set Pumps

Maximum fuel delivery on welder and generator set pumps is adjustable to reduce exhaust smoke under high altitude conditions. The setting may be done either on an injection pump test stand or by trial-and-error on a complete machine.

The simplest method is to run the machine at maximum output at high altitude. Loosen the torque screw jam nut and turn the torque screw in (clockwise) until exhaust smoke is reduced to acceptable levels. Retighten the jam nut. If the machine is returned to operation at sea level, the torque screw may be backed out to restore full sea level power. No adjustment will normally be required for operation under 3,000 feet. (See Torque Screw Location, page 31.)

Contact your Continental distributor for details.

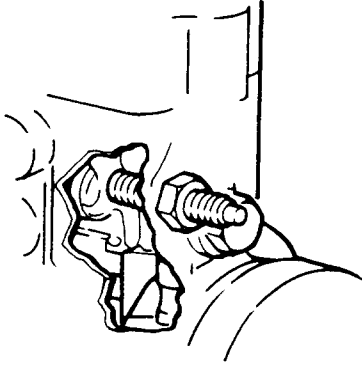

Torque screw location

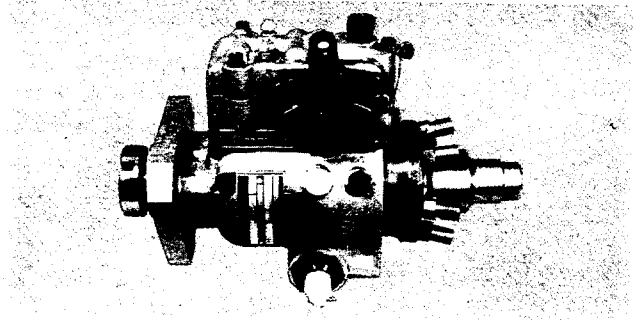

Typical DB2 Fuel Injection Pump

FUEL RECOMMENDATIONS

Diesel fuel selection, handling and filtration is of great importance. The fuel not only supplies the energy for all the work done by the engine — it also *lubricates* the parts of the fuel injection system which operate with very close tolerances. Fuel that contains water, abrasives, or sulphur in excess of our recommended specifications can cause extensive damage to the injection pump and engine.

DIESEL FUEL SPECIFICATIONS

Continental Diesels have been designed and developed to use ONLY No. 1-D (light fuel) and preferably No. 2-D (heavy fuel) — which can be a cracked residual, a blend of preferably a straight-run distillate having the following characteristics:

Refer to page 11 for seasonal fuel recommendations.

(listed in order of importance)

DIESEL FUEL CHARACTERISTICS	EFFECT	RECOMMENDED LIMITS
Cetane Number	Indicative of Ignition Quality, Higher number—better Starting and Idling.	50 desired 45 minimum
Volatility: Initial Boiling Point	To prevent premature vaporization during hot weather operation.	320°F. minimum
50% recovery 90% recovery End Point	Less smoke with fuel at low 50% and 90% Recovery Temperatures. Higher end points only partially burn, causing build up of deposits in energy cell and nozzle, causing pintle sticking and smoke.	550°F. maximum 650°F. maximum 700°F. maximum
Distillation Recovery	Lower % recovery indicates heavy oil fractions which cause smoke and poor combustion.	98%
SU Viscosity 100°F. (38°C)	Viscosity is a measure of flow resistance—the low limit minimizes leakage and lubrication and the higher limit insures penetration and atomizations.	31 - 40 seconds
Water and Sediment	Water in fuel causes corrosion; rapid pump wear and clogged filters.	.05% maximum by volume
Pour Point	Fuel Oil must be in fluid state to prevent clogging due to congealing wax.	10° below lowest anticipated operating temperature
A.P.I. Gravity @ 60°F.	Lower Gravity Fuels contain more heat Units/Gal.	30 minimim (A.P.I. Degrees)
Total Sulphur	Sulphurous acids corrode and increase engine wear.	.5% maximum
Corrosion (Copper) 3 Hours @ 212°F.	Discoloration or pitting on polished copper strip shows same effect on engine parts.	pass test
Ash	Amount of non-combustible material is abrasive and causes pump wear.	.01% maximum by weight

Section 6 - Charging System

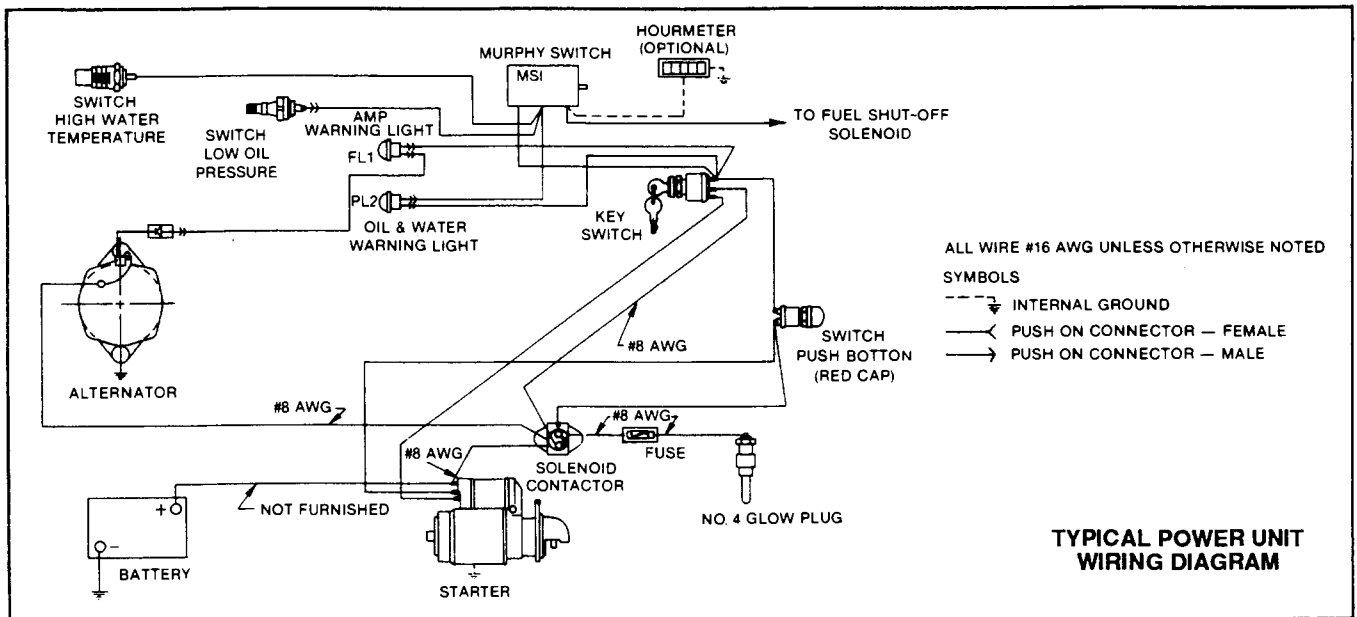
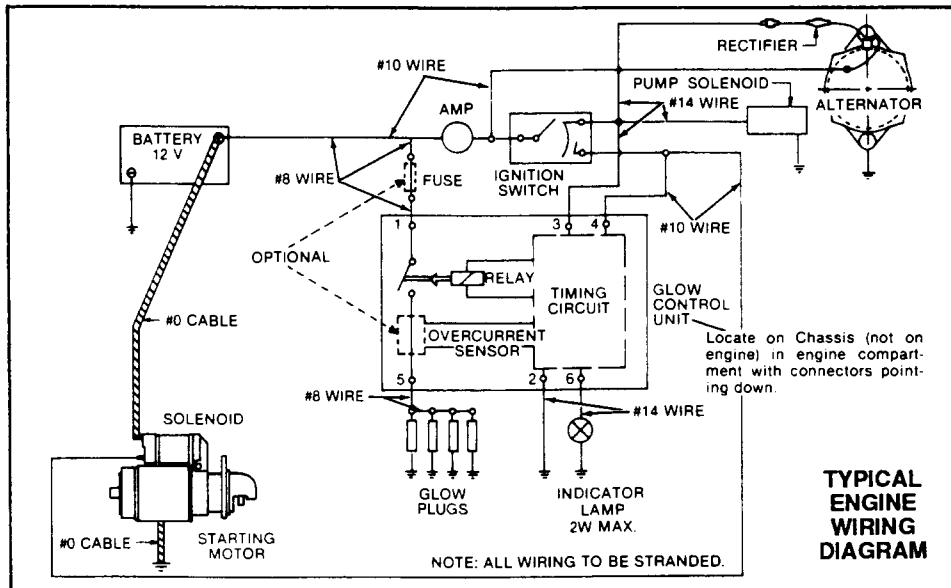

The charging circuit consists primarily of an alternator, regulator, battery and wiring. When analyzing the charging circuit, the components should be checked in the following order:

I. Wiring

Wiring in the charging circuit should be carefully inspected for frayed insulation or other damage, and replace any wiring that is defective. Also inspect all connections to the alternator, regulator and battery (including all ground connections), and clean and tighten as required.

II. Battery

Battery condition is very important for proper starting.

The lead-acid storage battery, used on automotive and industrial applications, is an electrochemical device for converting chemical energy into electrical energy.

It has two major functions:

1. It provides a source of current for starting the engine.
2. It can, for a limited time, furnish current when the electrical demands of the unit exceed the output of the alternator.

WARNING

Stop engine before checking battery terminals or electrical connections. Sparks or flames near a battery could cause an explosion or fire. Battery acid can cause corrosive burns. Always wear eye protection. Use of jumper cables or battery charging should be done only as directed by manufacturers' safety instructions.

Read and observe safety warnings on pages 1 and 2.

Refer to equipment manufacturer for battery recommendations.

III. Alternator

The alternator differs from the conventional D.C. shunt generator in that the armature is the stationary member and is called the stator; while the field is the rotating member and is called the rotor. Alternating current is rectified (changed to direct current) by means of diode rectifiers rather than mechanically with brushes coming into contact with the various segments of the rotating armature on the generator. With this construction, the higher current values involved in the armature or stator may be conducted to the external circuit through fixed leads and connections rather than through the rotating commutator and brushes as in D.C. generator. The comparatively small values of current supplied to the field may be conducted without difficulty through small brushes and rotating slip rings.

The alternator is somewhat lighter and more compact in design than the conventional D.C. generator of comparable electrical size and is equally as simple to service and test.

Each bearing is prelubricated which eliminates the need for periodic lubrication.

Precautions to be observed when testing or servicing the alternator system:

1. **Disconnect the battery**, before connecting or disconnecting test instruments (except voltmeter) or before removing or replacing any unit or wiring. Accidental grounding or shorting at the regulator, alternator, ammeter or accessories, will cause severe damage to the units and/or wiring.
2. **To avoid damage to the regulator, do not, at any time, connect battery to the regulator field terminal.**
3. **The field circuit must never be grounded, on this system, between the alternator and the regulator.** Grounding of the field terminal either at the alternator or regulator will damage the regulator.
4. **If it is necessary to solder any lead to a rectifier lead**, use a pair of pliers as a heat dam between the solder joint and the rectifier.

5. **The alternator must not be operated on open circuit with the rotor winding energized.**
6. **Do not attempt to polarize the alternator.** No polarization is required. Any attempt to do so may result in damage to the alternator, regulator, or circuits.
7. **Grounding of the alternator output terminal may damage the alternator and/or circuit and components.**
8. **Reversed battery connections may damage the rectifiers, wiring or other components of the charging system.** Battery polarity should be checked with a voltmeter before connecting the battery.
9. **If a booster battery or fast charger is used, its polarity must be connected correctly to prevent damage to the electrical system components. (positive to positive, negative to negative.)**

IV. Regulator

Most regulators are fully transistorized and completely sealed. These cannot be adjusted or repaired, and it can be assumed that this type regulator will outlive the other components in the charging system.

Other regulators are adjusted and repaired in accordance with the manufacturer's instructions.

Installation of Regulator for Alternator

To insure proper operation and to protect the alternator and regulator, the following steps should be observed during installation.

1. Make sure regulator is of the same voltage and polarity as the alternator and battery.
2. Disconnect battery cable at battery terminal.
3. Make sure the mounting area of the alternator and regulator base are clean and make a good tight connection.
4. Connect alternator in accordance with the manufacturer's instructions.
5. Do not flash field or ground terminals of the regulator.
6. Reconnect battery cable.
7. Start engine and observe ammeter. A "High" charge rate is normal for the first few minutes, but will decrease as the battery recharges.

Note: When servicing the charging system, never remove a unit until tests have shown it to be defective. Reference always should be made to the manufacturer's maintenance manuals for complete trouble shooting instructions.

Section 7 - Preventive Maintenance

In order to obtain maximum efficiency from your diesel engine, a definite maintenance program should be set-up and followed. Haphazard maintenance will only lead to faulty engine performance and shorten engine life.

All moving parts in the engine are subject to wear; however, wear can be reduced by careful operation and a planned maintenance program.

In general, diesel engine operation demands careful attention to the cleanliness of air, fuel and oil and maintaining coolant operating temperatures of 81°-93°C (180°-200°F.).

The following pages, covering Daily, 50, 250, 400 and 500 hour maintenance, have been worked out with our field service division as "Minimum Requirements" to keep your engine in dependable operating condition.

DAILY PREVENTIVE MAINTENANCE SCHEDULE

1. OVERALL VISUAL INSPECTION OF ENGINE

Look for evidence of fluid leaks on floor, cylinder head and block, indicating loose fuel, oil or water connections—tighten if found.

2. CHECK OIL LEVEL OF ENGINE

The dipstick indicates the high and low oil level in the crankcase—make allowance for additional oil drainage back into oil pan if engine has not been stopped 15 minutes. The most efficient oil level is between the two dipstick levels.

IMPORTANT: Do not add oil until oil level approaches the low mark—then add only enough to bring it to high level—NEVER above.

Do not operate the engine with oil below low level mark.



Check Oil Level of Engine

3. CHECK RADIATOR

Fill radiator with a clean 50/50 water/anti-freeze mixture to normal level maintained due to expansion

when heated. Visually inspect fan and belt for condition and adjustment.

4. FILL FUEL TANK

Fill fuel tank at end of day's operation to prevent condensation forming in tank. Clean filler cap and area around spout before filling to prevent entrance of dust into fuel system.

5. CHECK AIR CLEANER

All engines, when operating, consume several thousand cubic feet of air per hour. Since dusty air is full of abrasive matter, the engine will soon wear **excessively** if the air cleaner does not remove the dust before entering the cylinders.

On any air cleaner, operating environment dictates the air cleaner service periods. In extremely dusty operations this may be once or twice daily. In dust protected areas the air cleaner should be serviced when changing oil.

One basic type of air cleaner is normally used—the dry replaceable element type.

DRY TYPE REPLACEABLE AIR FILTER

Dry type air filters are standard equipment on many engines and it is most important that the dirt buildup in the cartridge does not reduce the air flow sufficient to cause a noticeable loss in power.

They should normally be serviced every 50 hours in the following steps: (Extreme conditions will require daily cleaning.)

Remove cover and cartridge after removing wing bolt - do not allow dirt to fall into the exposed carburetor.

Clean cartridge by gently tapping flat on a smooth horizontal surface to loosen and remove the heavier dirt deposits.

CAUTION: Do not damage the gasket sealing surface or bend the outer screen portion of the cartridge while cleaning. Replace the cartridge if in doubt!

The cartridge can also be cleaned with compressed air, but it is important to use the following guidelines:

- **ALWAYS** keep air pressure adjusted to less than 30 psi (2 Bar).

WARNING

Wear protective glasses or a face protect r wh n- ever air hoses are used. Never use air pressur that is more than 2 Bar (30 pounds per square inch) and make sure the air line is equipped with a water filt r to prevent damage to parts.

Read and observe safety warnings on pag s 1 and 2.

- **ALWAYS** keep the tip of the air nozzle or air hose at least 2 inches (50mm) from the paper portion of the cartridge.
- **ALWAYS** blow th cartridge clean from the inside out.

CAUTION: Failure to comply with the above guidelines will damage the cartridge and lead to severe engine damage. Replace the cartridge if in doubt!



Cleaning Dry Type Air Filter

Wipe inside screen, cartridge gasket surface, inside cover and mounting seat before installing element.

Place cartridge on mounting seat - make sure outer edge of cartridge fits inside edge of bottom plate.

Replace cover and assemble wing bolt finger tight to insure air filter seal.

CAUTION: Do not wash or oil cartridge.

Replacing New Cartridge.

Replace immediately if bent, crushed or damaged. Dry type air cleaners are efficient only as long as top and bottom sealing edges are not damaged.

Also surface of air cleaner base and cover where air cleaner cartridge seals, must be clean and not damaged, such as dents or bends.

Often in cleaning the cartridge it is tapped against surfaces that are not flat, thus damaging sealing edges. Regardless of how clean the paper is, **if edges are damaged dirt will enter the engine.**

The element should be replaced every 250 hours or when servicing does not result in full power recovery - whichever occurs first.

Under extreme dust conditions, more frequent replacement will be required.

NOTE: A 1/4 teaspoon of dust per hour can ruin an engine in one 8 hour day.

PCV SYSTEM

All connections must be air tight.

Blow-by circulates into the intake manifold maintaining crankcase pressure within a narrow range regardless of operating speed or load.

Servicing of the PCV system is confined to checking the conditions of the hoses and connections.

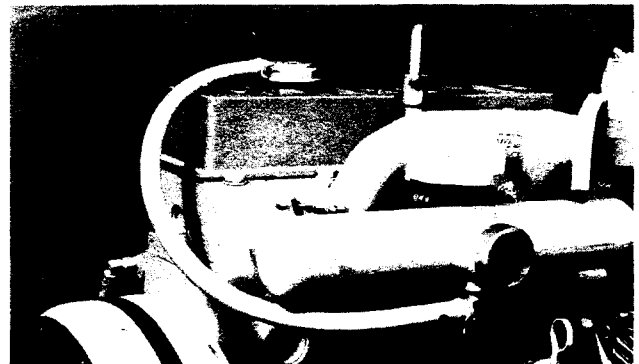

Typical Teledyne Continental Motors PCV System Installation

CHECK OIL PRESSURE

Note oil pressure gauge which should indicate the following pressure range at full throttle and a minimum of 0.5 Bar (7 pounds) pressure at idling speed.

MODEL	OIL PRESSURE
TMD	2.8 - 4.1 Bar (40 - 60 PSI)

Higher oil pressures may be experienced during cold starts.

NOTE ANY UNUSUAL NOISE

Operators familiar with daily engine operation soon become alert to any noise not normally present. This is very valuable in correcting defects in the early stages and preventing expensive repairs or delays.

EVERY 50 HOURS

1. REPEAT DAILY OPERATIONS OUTLINED

Follow previous Instructions.

2. CHANGE CRANKCASE OIL

Engine life is dependent upon clean oil being circulated to all moving parts; therefore, the frequency of oil changes and oil filter replacement is very important and should be made at regular, scheduled periods.

The schedule for changing oil is directly dependent upon the operational environment: an extremely clean operation could go 100 hours while a dirty operation (foundry or cement factory) could be 50 hours or less.

Replace the oil filter element every time the oil is changed.

Thoroughly clean the sealing surfaces before replacing new element and gasket.

Do not put kerosene into the crankcase. The best method is to drain the oil when the engine is thoroughly heated—which will carry off most of the sediment.

Some operators unwisely put kerosene in the crankcase after draining the engine oil, then turn the engine over with the starter—in the belief they are doing a better job of crankcase cleaning.

In doing this, kerosene is circulated through the oil pump, the main oil header and the branches leading into the engine bearings—thereby washing away the protective oil film. In addition, some of the kerosene will be trapped and remain to thin out the new oil, reducing its lubricating qualities.

3. SERVICE AIR CLEANER

Clean element with compressed air. (**See Daily Instructions.**) Be sure that no unfiltered air can enter the engine.

4. CHECK FAN BELT TENSION

Inspect wear condition of fan belt; note alignment and check belt tension which should allow not over 13mm (1/2") deflection on the long span.

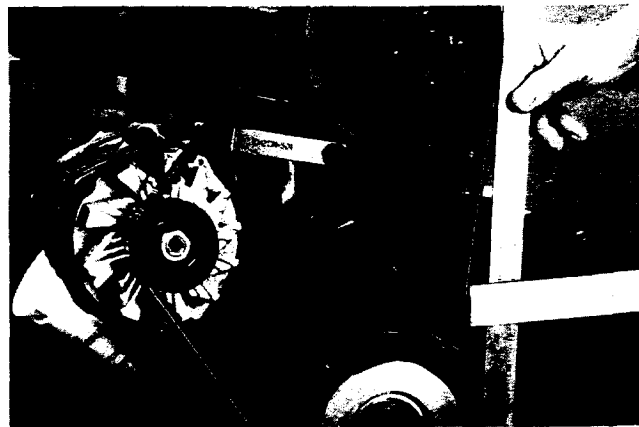

Fan Belt Tension

5. CHECK BATTERY

⚠ WARNING

Stop engine before checking battery terminals or electrical connections. Sparks or flames near a battery could cause an explosion or fire. Battery acid can cause corrosive burns. Always wear eye protection. Use of jumper cables or battery charging should be done only as directed by manufacturers' safety instructions.

Read and observe safety warnings on pages 1 and 2.

Check specific gravity of each cell—which should be at least 1.250. Add distilled water, if required, to raise level 9.5mm (3/8") above the separators.



Checking Battery

Particular attention should be given the battery during cold weather. The cranking power of a fully charged battery @ 27°C (80°F.) is reduced 60% @ -18°C (0°F.)—but yet the power required to crank the engine is 2 1/2 times greater at -18°C (0°F.) than @ 27°C (80°F.).

6. DRAIN WATER FROM FUEL FILTER(S)

Note: Some fuel filters are not equipped with a water drain. (See Fuel Filters, page 23.)

7. ADJUST IDLE SPEED TO EQUIPMENT MANUFACTURERS RECOMMENDATION

Repeat again at end of 500 hours.

EVERY 250 HOURS

1. REPEAT DAILY AND 50-HOUR SCHEDULES

Follow previous instructions.

2. CLEAN EXTERIOR OF ENGINE

Use steam if available, otherwise any good commercial engine cleaner to wash down the engine.

CAUTION: Never allow cool water to come in contact with the fuel injection pump while the engine is running! Injection pump seizure may result.

3. CHECK GLOW PLUGS

Inspect glow plug wiring.

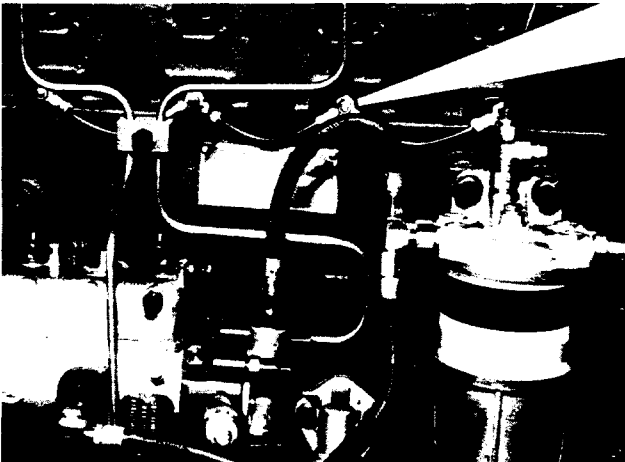

Glow Plugs

4. IF DRY REPLACEABLE ELEMENT AIR CLEANER IS USED, REPLACE ELEMENT.

5. FIRST 250 HOURS RECOMMEND ADJUSTING VALVE TAPPET CLEARANCE.

EVERY 400 HOURS

1. REPEAT DAILY AND 50-HOUR SCHEDULES

Follow previous instructions.

2. FUEL SYSTEM (See fuel filters - page 23)

Replace fuel filter element.

Inspect mounting and gaskets.

Check all connections for leaks.

EVERY 500 HOURS

1. REPEAT DAILY — 50 HOUR AND 250 HOUR SCHEDULES.

2. COOLING SYSTEM

Clean radiator core by blowing out with compressed air.

Inspect radiator mounting.

Inspect water pump and connections for leaks.

Check fan and accessory drive belts.

3. ADJUST VALVE TAPPET CLEARANCE

Check and adjust intake and exhaust valve tappets to following clearances at operating temperature.

MODEL	INTAKE	EXHAUST
TMD	0.36mm (.014")	0.46mm (.018")

4. SAFETY AND THERMAL CONTROLS

Inspect control wires and connections.

Section 8 - Engine Repair and Overhaul

This section includes instructions for repairs and overhaul of the component units of Continental industrial diesel engines.

Provide a clean place to work and clean the engine exterior before you start disassembling—*dirt causes engine failures.*

Many shop tools have been developed to save time and assure good workmanship; these should be included in your equipment.

Use only genuine Continental parts in Continental engines since years of development and testing have gone into these specifications to assure maximum life and performance.

CYLINDER HEAD

The cylinder head is the most important part of the engine assembly since it contains the complete combustion chamber including valves, fuel injection nozzles, glow plugs, and cored passages for air, exhaust and water flow.

REMOVING THE CYLINDER HEAD

1. Drain water from engine and disconnect radiator or heat exchanger hoses.
2. Remove cylinder head cover by removing the capscrews holding the cover to the cylinder head.
3. Remove rocker arm shaft assembly and push rods. Grip the push rods and snap them sideways out of the tappet sockets as shown in the illustration. This method serves to break the hydraulic connection and permits lifting the push rods out and leaving the tappets in place.

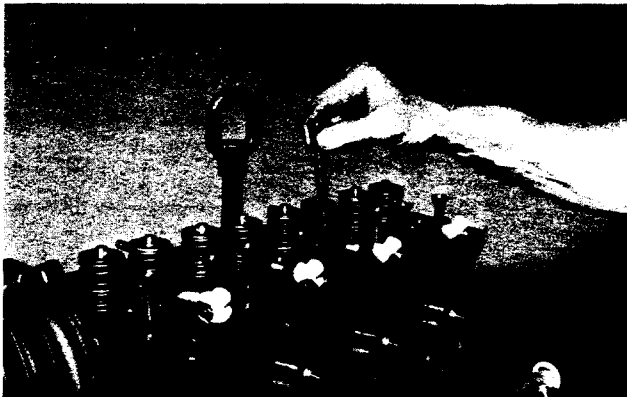

Removing Push Rod from Ball Socket of Tappet

4. Disconnect the injectors and leak-off lines at both the nozzle and pump connections.



Socket relief clearance

Caution should be used when replacing the fuel injectors to prevent loosening the injector leak-off nipples.

Be sure to cut a relief in the inside of your socket for clearance. This will prevent an interference between the socket and the leak-off nipple.



Disconnecting Injector Leak-off Line

CAUTION: Always cover openings with protective caps at any time when lines are disconnected. This will prevent any dirt or foreign matter from entering.

5. Remove injection nozzle assemblies. Place a protective cap over ends of injector for keeping openings clean. Refer to fuel injection system for testing procedures, page 24.

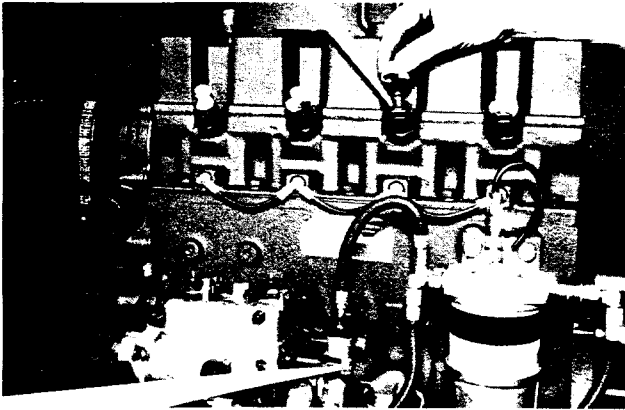

Capping Injector Connections

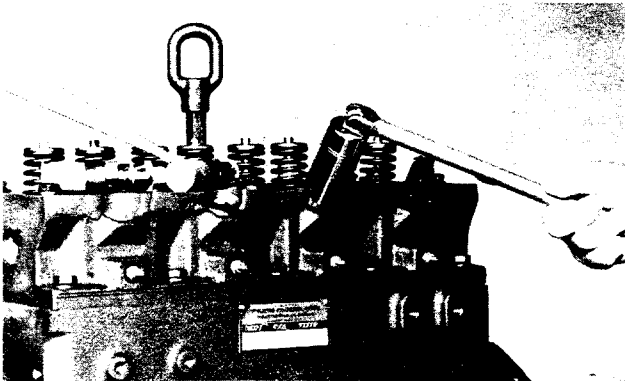

Injector with Protective Caps and Nozzle Removal

6. Remove glow plugs.

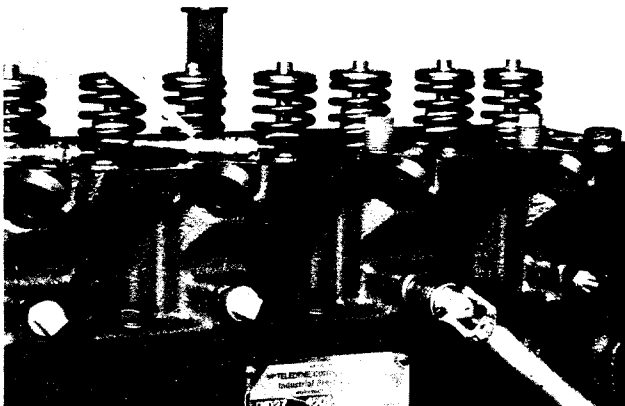

Glow Plugs

7. Loosen and remove the capscrews holding the cylinder head to the block.

8. Lift the cylinder head off the engine and carry to a clean bench for further disassembly.

DISASSEMBLY OF CYLINDER HEAD

1. Using a C type valve spring compressor, remove the valve spring retainer locks, retainers, rotors, springs and oil seals on valve stems—placing all parts in a container of solvent.

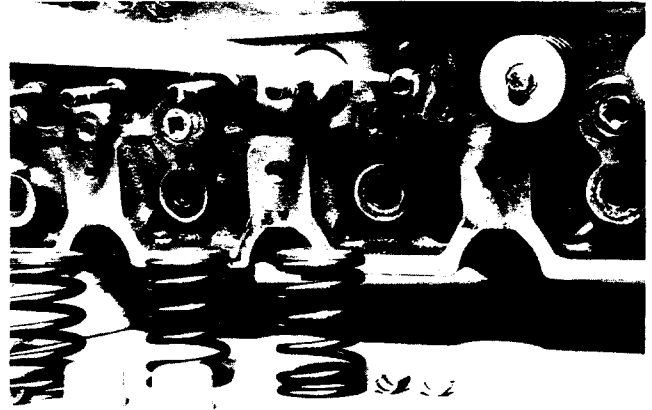

Removing Valve Springs

2. Remove the valves and place them in order in a rack with holes numbered for both intake and exhaust so they will not be mixed in handling.

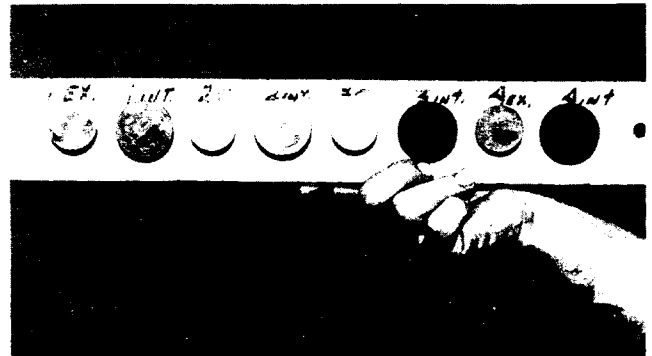

Valves in Rack

3. Remove precombustion chamber inserts from cylinder head and place in a rack indicating the cylinder from which each was removed.

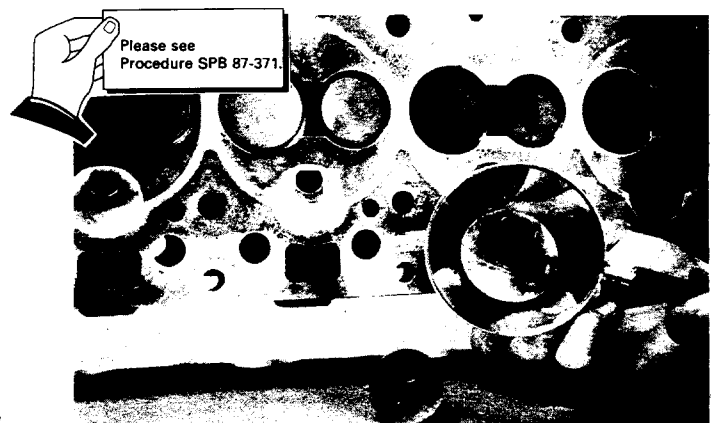

Precombustion Chamber Inserts

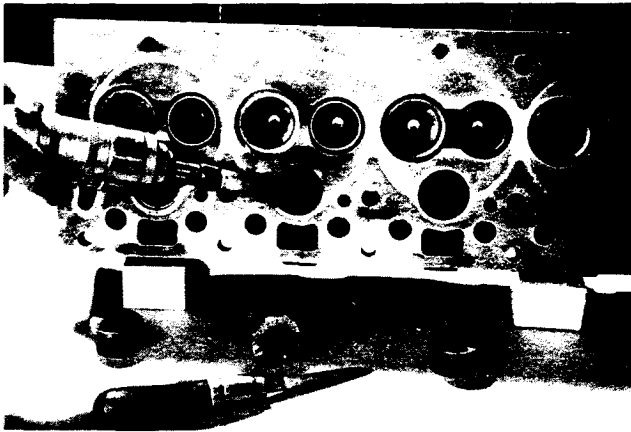

Cleaning Combustion Pocket

Clean insert and combustion pocket. Inspect carefully for cracks.

4. Remove all carbon from combustion areas using scraper and wire brush.

5. Clean the cylinder head thoroughly with a solvent or degreasing solution and blow it off with air pressure. Inspect carefully for cracks.

VALVE GUIDES

1. Clean the valve stem guides, removing lacquer or other deposits. Do not use tools that remove metal.

2. Check guides for wear by using a telescope gauge and 1" micrometer. Replace all guides that are worn bell-mouthed or have increased 0.038mm (.0015) in diameter. See Limits and Clearance Section for maximum diameter permissible to determine actual amount it has increased. Remove all valve guides when necessary by pressing them out from the combustion chamber side.

3. Replace worn guides as required by pressing in new guides to the correct depth as given in the valve guide data, page 42.

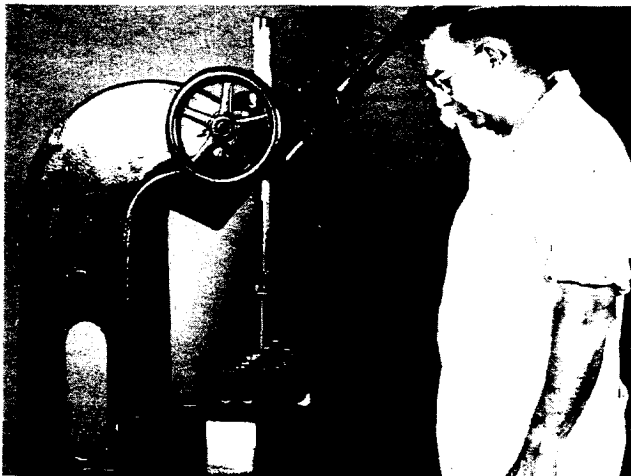

Removing Valve Guides from Combustion Chamber Side

CAUTION: When replacing guides do not ream since these are all pre-reamed before being ferrox coated—any further reaming will remove the coating.

VALVE SEAT INSERTS (IF SUPPLIED)

1. The exhaust valve seat insert is held in place by a shrink fit.

Inspect all exhaust valve inserts in the head and replace any that are loose, cracked or otherwise damaged. Use puller for removing faulty insert.

2. When required to replace with new insert, clean and counterbore for 0.25mm (.010") larger insert using counterbore tool with correct fitting pilot.

When machining the counterbore, be sure to go deep enough with the tool to clean up the bottom so that the insert will have full contact to carry away the heat.

Continental does not recommend installing new inserts having the same outside diameter as the one removed.

New insert installation must have a press fit. Chill insert in container with dry ice for 20 minutes before assembling.

Insert may then be installed in the counterbore using a piloted driver and arbor press, without the possibility of shearing the side walls. This assures it being seated firmly on the bottom of the counterbore.

3. Grind the intake and exhaust valve seats in the head in accordance with instructions in the Valve Guide Data, page 42. Before removing the arbor, indicate the seat. Total indicator reading of the run-out must not be more than 0.05mm (.002"). Use a pilot having a solid stem with a long taper, as all valve seats must be ground concentric and square with either new or worn valve stem guide holes.

VALVE GUIDE DATA

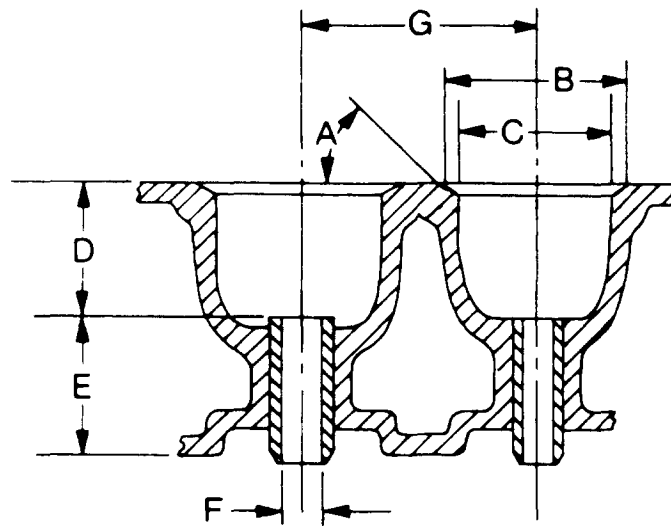

		Model TMD	
		Intake	Exhaust
A	Valve Seat Angle	30°15'	45° 15'
B	Diameter of Seat	39.77 (1.566)	33.50 (1.319)
C	Diameter of Choke	35.0 (1.38)	29.0 (1.14)
D	Distance (From Bottom of Cylinder Head)	43.0 (1.69)	43.0 (1.69)
E	Length of Guide	60.4 (2.38)	60.4 (2.38)
F	Inside Diameter Guide	8.717/8.692 (.3432/.3422)	8.717/8.692 (.3432/.3422)
G	Distance Intake to Exhaust	47.65 (1.876)	—



Grinding Valve Seat

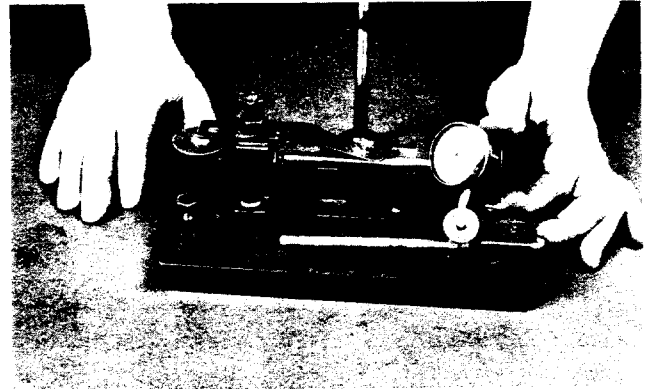

Checking Valve Face in "V" Blocks



Indicating Valve Seat

3. Check all refaced or new valves in V-blocks with indicator to determine if the contact face is true with the stem within 0.05mm (.002"). If not, repeat the refacing operation.
4. After the valves and seats have been refaced and reground, coat the seat lightly with Prussian blue and drop the valve into position, oscillating it slightly to transfer the blue pattern to the valve face. This should show a contact width of 1.62 to 3.2mm (1/16" to 3/32") and should fall well within the width of the valve face, leaving at least 0.4mm (1/64") on either side where the blue does not show. If the contact is over 3.2mm (3/32") wide, the seat in the head may be narrowed by using a 15° stone to reduce the outside diameter or using a 60° or 75° stone to increase the inside diameter.

VALVES

1. Inspect valves for condition and replace any that are "necked", cracked or burned, also any of which valve stems are bent or worn more than 0.05mm (.002") over the maximum allowable limits. Reface or replace all valves.

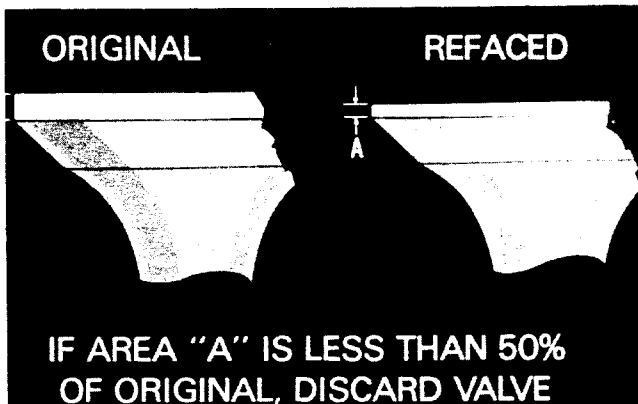

Allowable Head Thickness of Refaced Valves

2. All valves having less than 50% margin thickness (outer edge of valve head) after refacing has been completed must be replaced. To check this dimension, compare the refaced valve with a new valve.

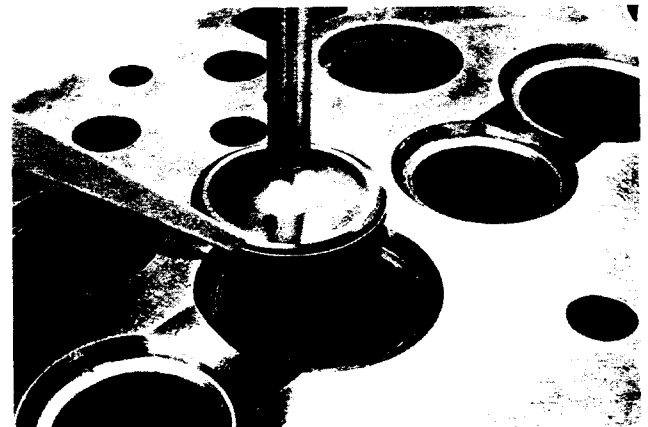

Checking for Proper Valve Seating

Never allow valves to set down inside the seat.

After the narrowed-down seat is brought within specifications, the seat should be retouched lightly with the original stone to remove burrs or feathered edge.

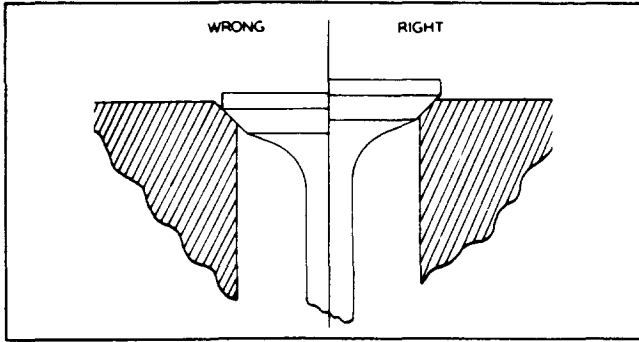

Valve Position in Head

“A poor valve grinding job cannot be corrected by valve lapping.”

For example, after the valve has been hand lapped, it would look like this when cold. The thin line visible here shows where the valve lapped into its seat. Keep in mind that the engine is now at rest and cold.

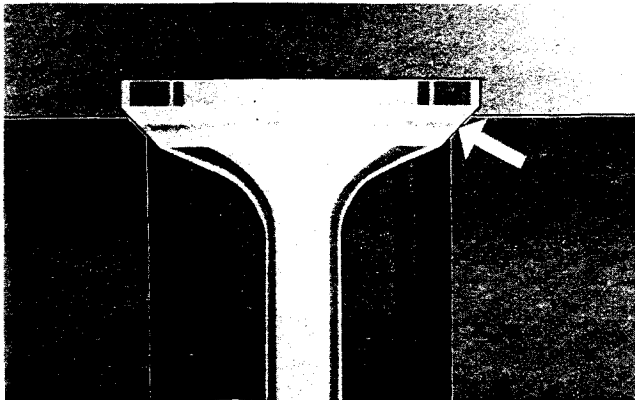

This illustration shows the same valve only now it has reached normal operating temperature. Notice that the lapped area of the valve and the seat no longer match each other. This is perfectly normal due to expansion of the valve. Now you can see that the effects of the lapping job are lost completely.

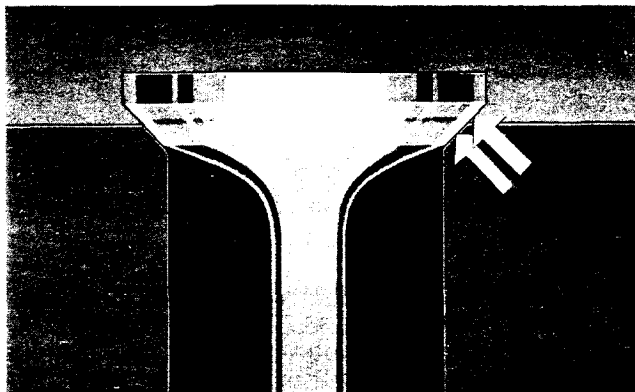

So remember... do not lap valves in after grinding.

5. Coat the valve stem with a light film of engine oil.

VALVE SPRINGS

1. Check all valve springs on a spring tester to make sure they meet specifications regarding weight and length.

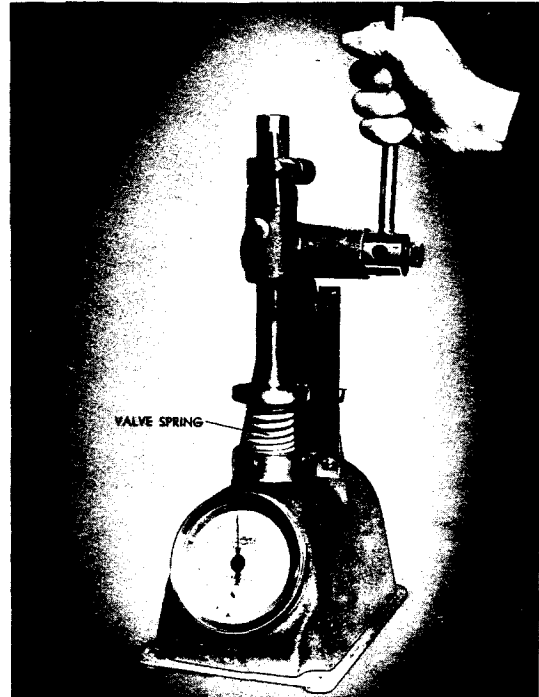

Valve Spring Tester

Springs, when compressed to the “valve open” or “valve closed” length, must fall within the specifications shown on the Limits and Clearance chart when new, and must not show more than 10% loss to re-use.



Valve Assembly

2. All intake and exhaust valves have umbrella seals. Soak in boiling water for several minutes prior to installation.

3. Reassemble the valves and springs in the head with the seal, retainer and retainer lock.

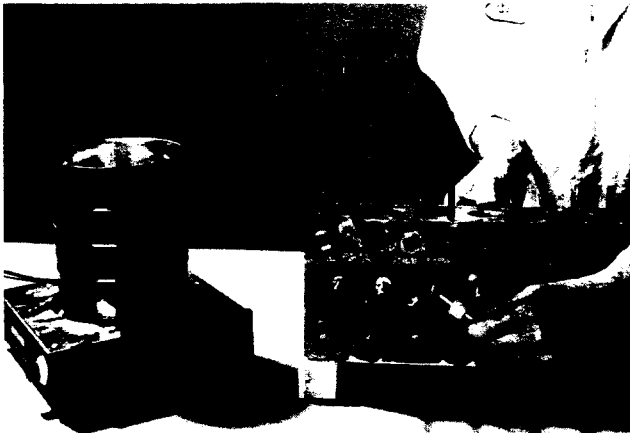

Installing Umbrella Seals

ROCKER ARMS

1. Inspect the rocker arm shaft for wear. If the shaft has "shoulders" on it due to wear, replace. Blow out oil holes with air.

2. Examine rocker arms for cracks, condition of valve contact surface and worn bores. Replace all defective rocker arms or any having over 0.13mm (.005") clearance between shaft and arm.

3. Inspect the rocker arm brackets for cracks or other damage.

VALVE PUSH RODS

1. Inspect push rods for bends or twist and examine the ball and cup ends for excessive wear. Replace rods that are faulty or excessively worn.

2. To prevent damage to push rods, replace after the cylinder head is installed.

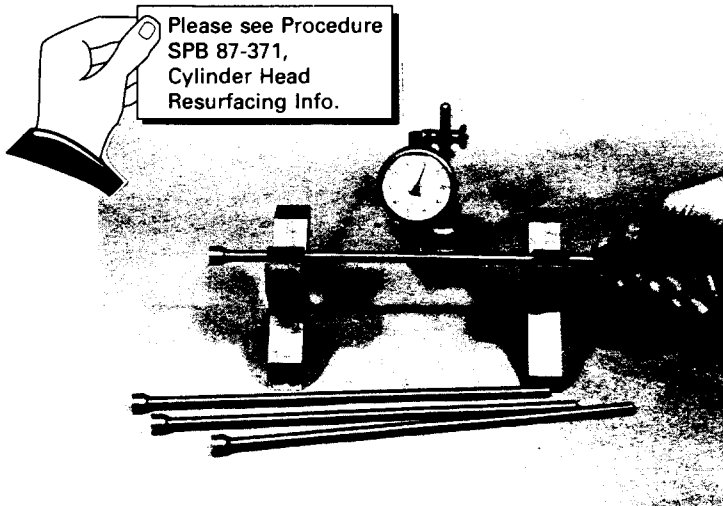

Push Rod Inspection for Runout

CHECKING BORE WEAR

1. Clean the ring of carbon from around the top of the cylinder bore formed above the travel of the top ring.

2. Determine the original diameter of the cylinder barrel by checking this unworn area with an inside micrometer or a dial bore gauge at intervals of approximately 45°.



Measuring Original Bore Diameter Above Ring Travel

3. Check in same manner the top of the ring travel area approximately 6mm (1/4") below the shoulder.

4. The maximum difference in the above checks, indicates the amount of cylinder bore wear. If less than 0.20mm (.008"), re-ringing will be suitable and if over 0.20mm (.008") re-boring is recommended.

PREPARING CYLINDER WALLS FOR RE-RINGING OR RE-BORING

1. Ridge ream the cylinders to remove the unworn area at the top so that the new rings when assembled will not bump and distort both themselves and the piston lands.

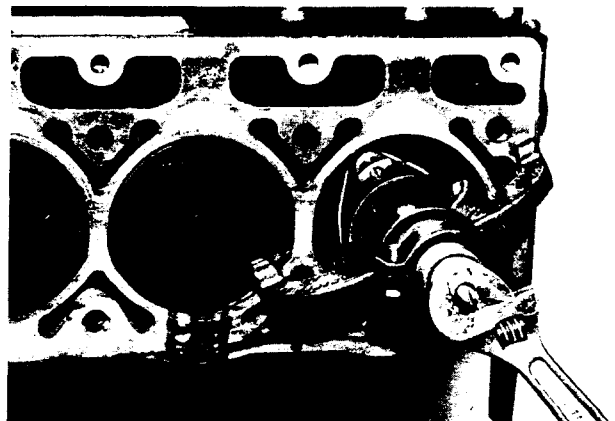

Ridge Reaming Top of Cylinder Bore

Several good makes of ridge reamers are available which will ream the top of the bore in direct relation to the worn area so that should the worn area be off center slightly there will be no partial ridge remaining.

2. Drain the crankcase and remove the oil pan.
3. Remove the cap screws holding the connecting rod caps to the rod. *Keep the cap and bolts in numerical order so that when the pistons and rods are removed from the engine, the cap can be reassembled and kept with its mating part.*
4. Push the pistons and connecting rods up through the top of the cylinder, carrying with them all the carbon and metal chips left from the cleaning and ridge reaming operation. *When doing this, every precaution must be taken to prevent damage to cylinder bores by the sharp corners and rough edges of the connecting rods.*
5. It is important to remove the glaze on the cylinder bores by using a cylinder hone, with an adjustable stone tension, in order to assure quick seating of the new piston rings. **If the cylinder glaze is not removed, you will have no assurance as to when the rings will begin to function properly and control the oil; this is especially true when chrome rings are used.**

The following step by step procedure is recommended:

- a. To get the correct cross hatch pattern with a cylinder hone, use a top quality electric drill with a speed of 500 R.P.M. or less and 280 grit stones.



Honing Cylinders

- b. Cover the entire crankshaft with a clean, slightly oily cloth to prevent abrasives and dirt from getting on the crankshaft.
- c. Remove the excess carbon deposits from the top of the cylinder wall before beginning the glaze breaking operation. (This is to prevent loading the stones.)
- d. Insert hone in cylinder and expand to cylinder wall with slight tension. Using a clean brush, wet cylinder wall and stones with kerosene. Use a hand drill and surface hone cylinder with a rapid up and down motion to produce a good crosshatch pattern. Apply kerosene continuously and increase tension on hone adjustment until a good pattern and finish is obtained. A smooth, bright finish of 0.25 - 0.38 Micro Meters (10 to 15 micro inches) is desired.

The honing operation will produce a sharp edge at the bottom of the bores. Upon completion of the honing operation, remove this sharp edge with a piece of number 500 emery cloth. If this edge is not removed, it can cause shaving of the piston skirts.

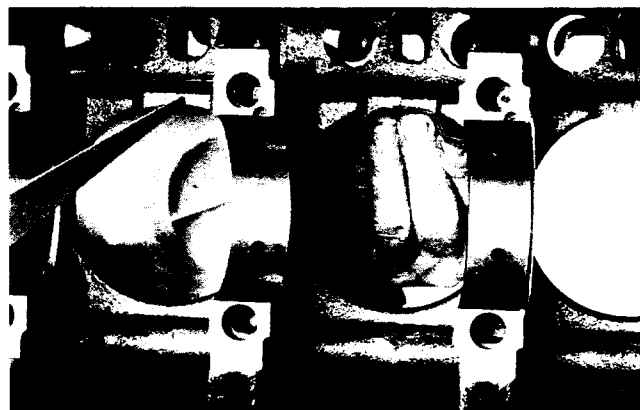

Removing Sharp Edge After Honing

- e. Clean the loose abrasives from the stones by using kerosene and a wire brush.

IMPORTANT: Stones must be used wet. Keep applying kerosene during honing to prevent stones from drying out and causing an incorrect honing pattern.

- f. The most desirable cylinder finish is 0.25 - 0.38 Micro Meters (10-15 micro inches); with this finish the depressions in the surface tend to keep a supply of lubrication between the mating parts. This finish can be obtained by using 280 grit stones on the hone.

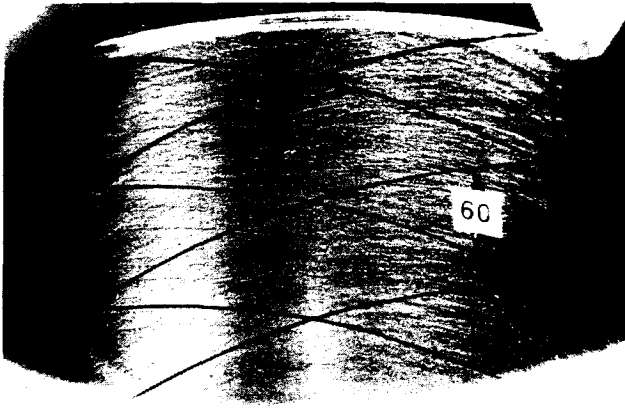

Desirable Crosshatch Pattern Obtained with a Cylinder Hone

After all honing operations are complete, thoroughly wash the bores with soap, hot water and a stiff brush to remove all traces of grit. Kerosene or other solvents will not remove the grit. Rinse the block with clean, clear water and dry with compressed air.



Cleaning Bores

When you have finished cleaning the block, run a clean, dry paper towel through the bores. The paper towel should come out clean.



Checking Block for Cleanliness

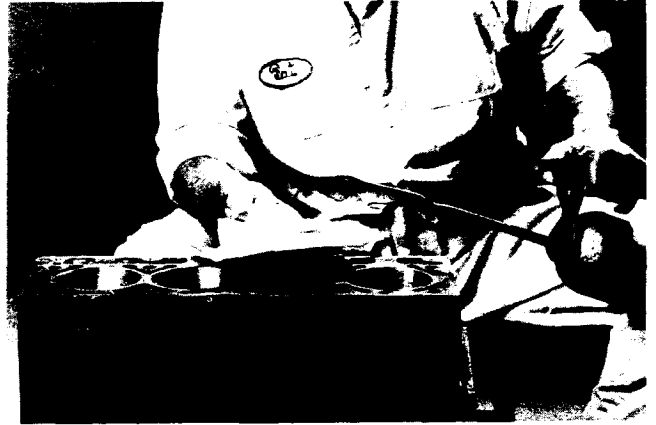

Oiling Bores

If not, the bores must be rewashed. As soon as the bores have dried, lubricate with engine oil immediately to prevent rust. This completes the honing operation.

PISTONS

Check the pistons for excessive ring groove wear, and replace any that exceed the allowable limits in our Limits and Clearance Data.

The cylinder walls and pistons must be perfectly clean and dry when fitting pistons in the cylinder bores. Pistons should be fitted with the block and piston at room temperature 20.0°-21.0°C (68°-70°F).

PISTON FIT ON STANDARD PISTONS
(with 2.3 to 4.5 kg (5 to 10#) Pull)
TMD series 0.08mm (.003")

Check the piston fit in the bore using a half-inch wide strip of feeler stock, of the thickness specified in the Limits and Clearance Chart, the feeler being attached to a small scale of approximately 7 kg (15 Lbs.) capacity.



Checking Piston Fit in Bore

When the correct fit is obtained you must be able to withdraw the feeler with a pull of 2.3-4.5 kg (5-10 pounds) on the scale, with the feeler inserted between the piston and the cylinder midway between the piston pin bosses where the diameter of the piston is the greatest. Check the fit of the piston when it is approximately 50mm (2") down to the cylinder bore in an inverted position.

PISTON PINS

Check the bushing in the upper end of the connecting rod for wear. If worn and you are using the original pistons, an oversize piston pin may be obtained in 0.08 or 0.13mm (.003 or .005") oversize.



Checking Piston Pin Bushing for Wear

The piston pin hole in the piston and the bushing in the connecting rod may be honed to increase their diameter to obtain the desired fit as shown in our Limits and Clearance Chart.

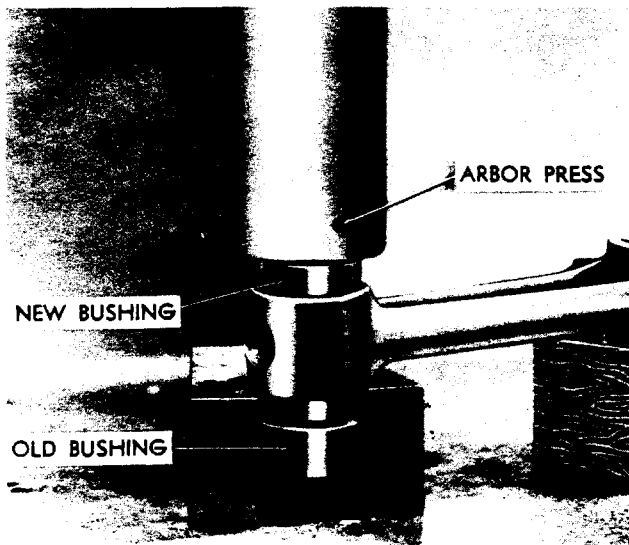

Pressing in Piston Pin Bushing

Note that while the chart specifies a light press fit of the pin in the piston, there is a definite clearance of the piston pin in the connecting rod.

CONNECTING RODS

Replace the bushing in the connecting rod if new pistons are used. Using the arbor press, press out the old bushing and press in the new one making sure the oil supply holes line up—after which the bushing must be honed to obtain the correct fit of the pin in the bushing as shown on Limits and Clearance Chart.

If there is an excess of stock in the piston pin bushing, it may be reamed first, then honed. In any event, the final operation should be done with a hone to obtain the desired fit with better than 75% bearing area contact on the pin.

PISTON AND CONNECTING ROD ASSEMBLY

1. Assemble the pistons on the connecting rod. Heating them in hot water will facilitate assembly. When heated, the piston pin will enter the piston very easily and can be tapped through the connecting rod and into place without distorting the piston. The snap rings must be assembled in the grooves, making sure they are fully seated in place.

2. The piston pin hole in the connecting rod must be parallel to and in plane with, the large bore in the bearing end of the connecting rod.

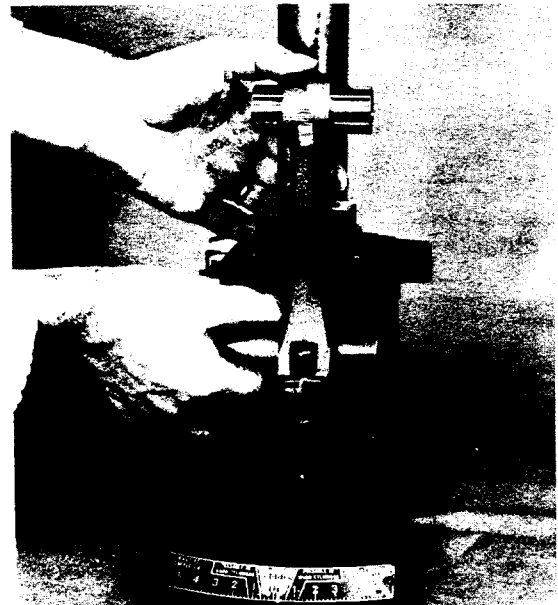

Checking Connecting Rod for Twist and Alignment

This may be checked on a fixture with the piston pin assembled in the rod before assembling the piston; but regardless of this preliminary

check the completed piston and rod assembly must be rechecked and there must not be more than 0.05mm (.002") twist or out of squareness checked over a spread of approximately 100mm (4"). If excessive, replace the rod.

Pistons are cam and taper ground, and this must be taken into consideration when checking alignment of the assembly, since the diameter in line with the piston pin would be less at the top of the skirt than at the bottom.

PISTON RINGS

Check the piston rings in the cylinder for gap.

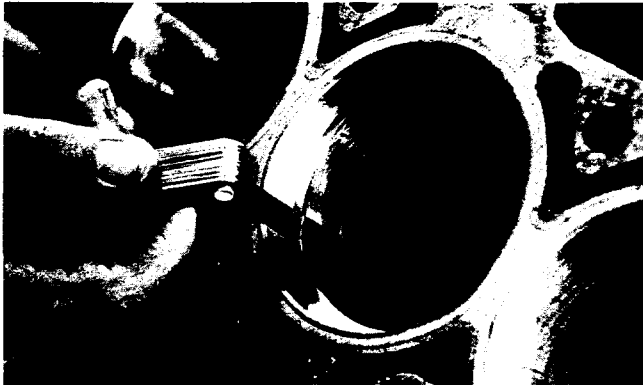

Checking Ring Gap

To do this, insert a piston in the cylinder bore in an inverted position and then insert each ring one at a time about 50mm (2") down in the bore. If the ring does not have sufficient end gap clearance, file one end of the ring until sufficient clearance is obtained.

Check the gap between the ends of the ring with a feeler gauge in accordance with specifications shown in the Limits and Clearance Chart.

Prior to installing the rings on the piston, check each ring in its respective groove to the limits specified in the manual. If ring to land clearance exceeds maximum serviceable limits, pistons must be replaced.



Checking Ring Clearance in Groove

RECOMMENDED METHOD OF INSTALLING PISTON RINGS

1. Prior to ring assembly check the ring grooves for nicks and burrs. This is done by rotating each unassembled ring around its groove to be sure of free action.



Installing Rings with Ring Expander Tool

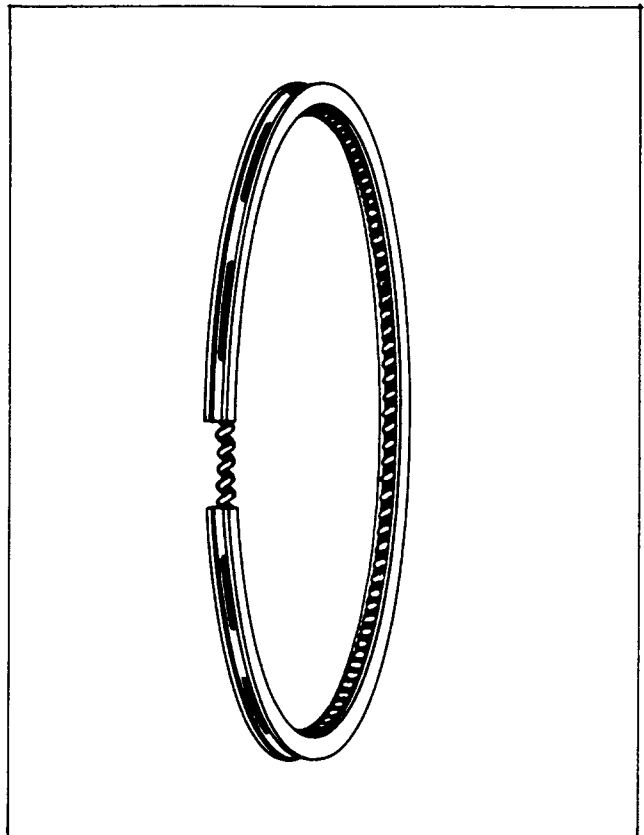

Oil Ring

2. The oil ring should be installed first on the piston, from the top side so skirt will not be scratched.

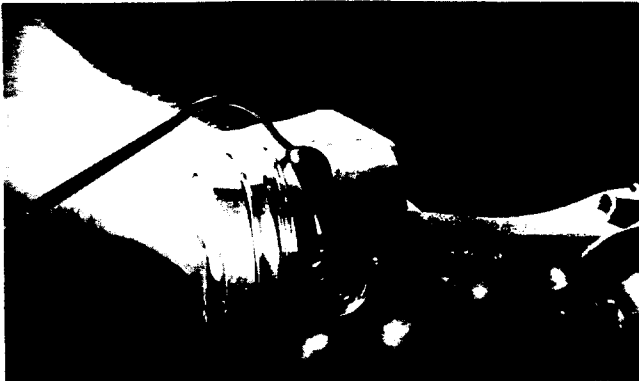

Oil Piston and Rings

3. To install the balance of the rings, use a ring tool with **recess** side up and place the ring in with the bottom side up. **Start with the lowest ring first.**

- a. Position ring in the tool so the expanding fingers will fully engage both ends.
- b. Apply pressure on handles so ring is completely expanded. Pass the expanded ring and tool **recessed side down** over the piston to the proper groove.

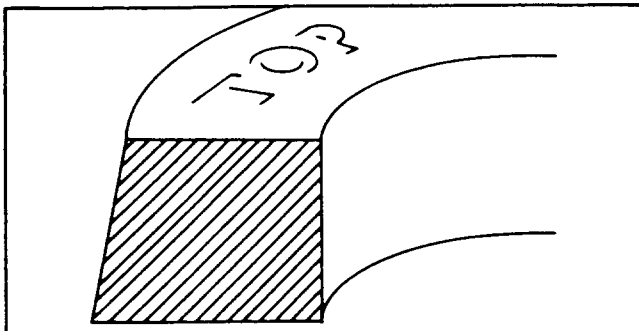

Install Tapered Rings with "Top" Side Up.

CAUTION: Some piston rings are taper faced. These are clearly marked "TOP" on the side to be up when assembled on piston, and some rings have the top side marked with a color band or a PIP mark.

4. When pistons are ready for installation in the cylinders, oil generously. Compress rings carefully using a good ring compressor and a light tap on the head of the piston will allow the assembly to go into the cylinder very easily. If any difficulty in tapping piston and ring assembly into the cylinder is encountered, the compressor should be removed and rings checked for correct installation in the groove.

CAUTION: The pistons have offset piston pins. Be sure to install pistons with notch or arrow in top toward the front of the engine.

CRANKSHAFT AND MAIN BEARINGS

1. Using a puller, remove pulley from crankshaft.
2. Remove screws and remove gear cover.
3. Remove the crankshaft gear and woodruff keys.
4. Using a puller, remove cam gear and injection pump drive gears.
5. Remove the oil pump and key by removing cap screws holding pump to front of the engine.

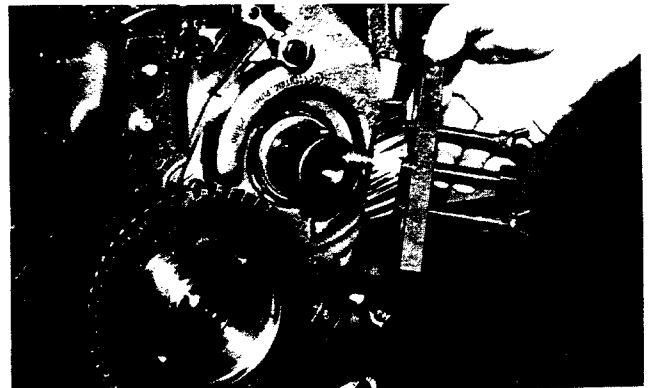

Removing Crank Gear

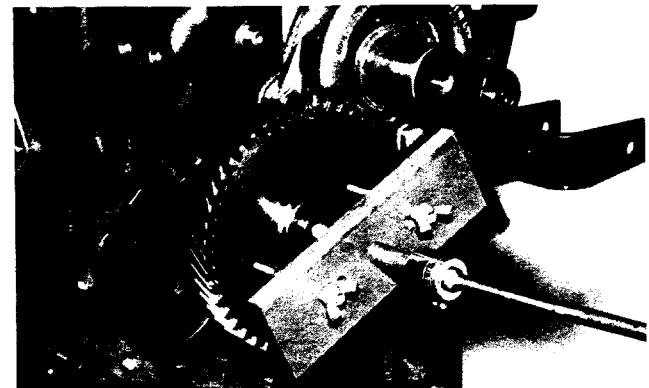

Removing Cam Gear with Puller

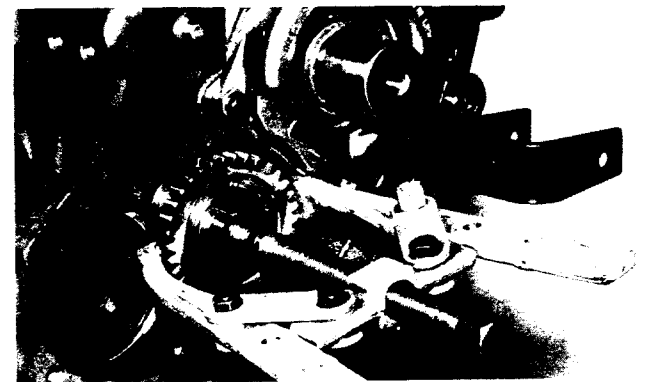

Removing Injection Pump Drive Gear

6. Remove each main bearing cap, one at a time, and inspect the bearing and crankshaft journals.

If there is any indication of flaking out, scoring or actual wear, — **they must be replaced.**

BEARINGS

Tri-metal bearings when new are smooth and highly polished. However, a very few hours of

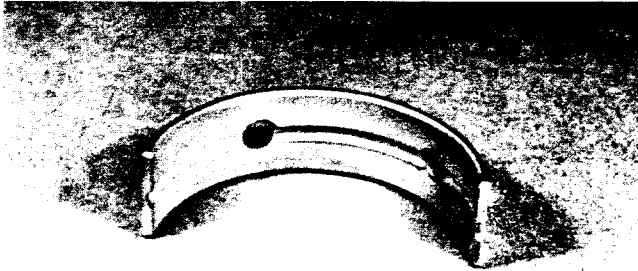

Appearance of a Good Bearing

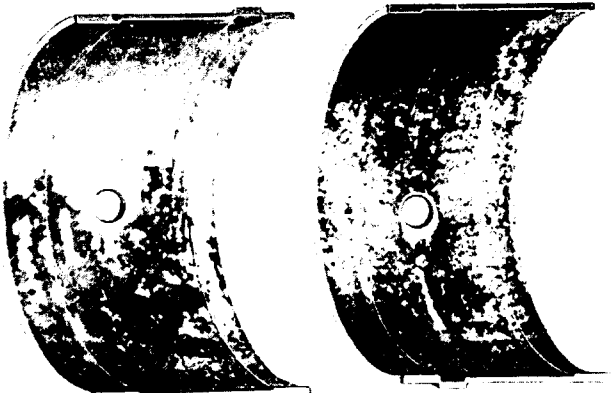

Bearing Damage Due to Corrosion

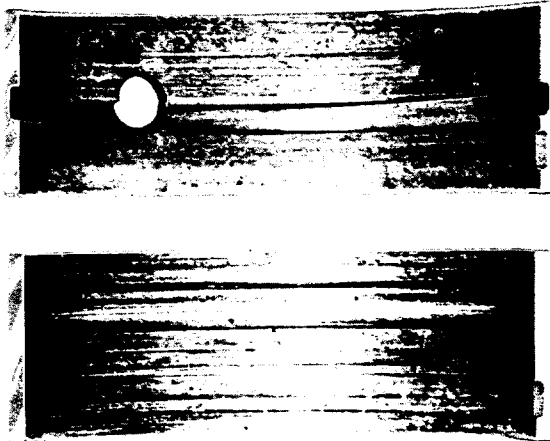

Scored Bearing Due to Dirt or Lack of Oil

operation will change their appearance completely. The bearing surface becomes a leaden gray in color and develops minute craters, almost cellular in appearance. This appearance is a natural characteristic of this type bearing and in no way indicates failure.

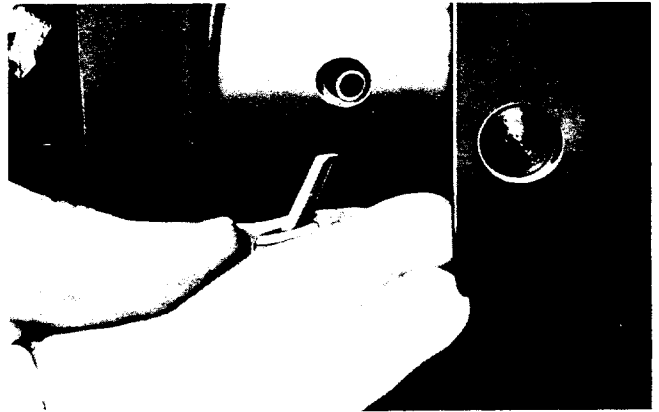

Removing Main Bearing

7. If the visual inspection appears satisfactory, they should be removed and checked for thickness using a ball micrometer.

To remove the upper half of the bearing shell use a special tool obtainable at most parts houses, which is a pin with an angular head. It may be inserted in the oil hole of the crankshaft and as the crankshaft is turned in a clockwise direction, the head of this pin picks up the bearing shell and forces it out of the bore in the block.

The thickness of the bearing shells is given in the Limits and Clearance Chart, and if this thickness has been reduced more than 0.013mm (.0005") beyond the maximum allowable tolerance the bearing shell must be replaced.

CAUTION: The upper main bearing shells are grooved. The lower main bearing shells on some models, are not. The ungrooved bearing shell must be placed in the bearing cap, not in the block, or oil to the bearings will be cut off.



Measuring Bearing Thickness

8. If visual inspection of the crankshaft shows no indication of excessive wear or scoring, the clearance of the bearing should be checked.

9. Check each bearing, one at a time, by using a piece of Plastigage of a diameter specified to check certain clearances.

TMD	2.8R (.11") on all crankpins 3.0R (.12") on all mains'
-----	---

Crankshaft Fillet Radii

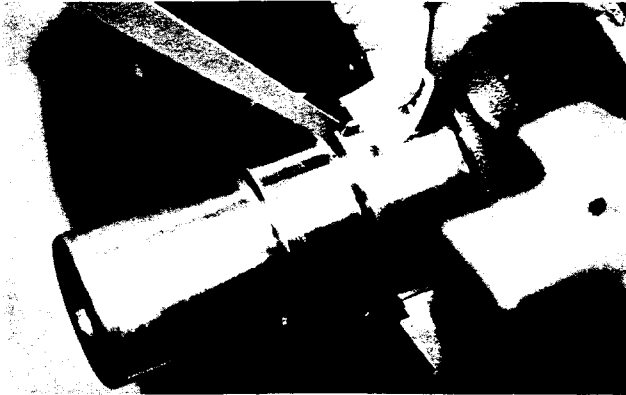

Checking Bearing Clearance with Plastigage

By placing the Plastigage on the crankshaft bearing surface and tightening the bearing and cap in place, the width of the Plastigage after crushing will determine the bearing clearance.

CAUTION: When using this method DO NOT TURN the crankshaft as that would destroy the Plastigage.

If crankshaft is scored, or worn enough so that new bearings will not fit with the required clearance, it should be removed and reground.

Standard crankshafts may be reground to decrease the diameter a maximum of 1.0mm (.040").

Before shaft is reground, it must be checked for straightness and straightened if necessary to be within 0.05mm (.002") indicator reading. When reground, the fillet radii must be within dimensional limits and must be perfectly blended into thrust and bearing surfaces. **Crankshafts must be nit mpered after regrinding.**

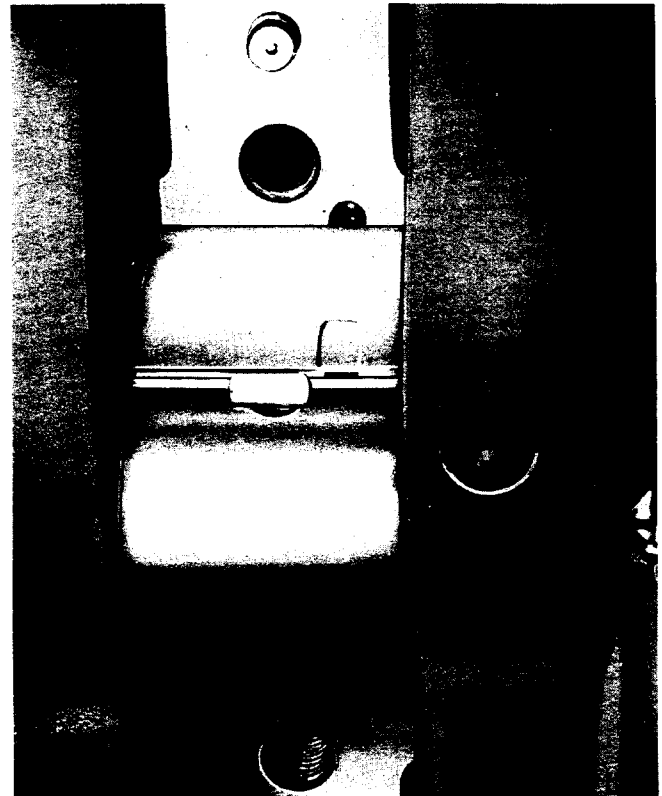
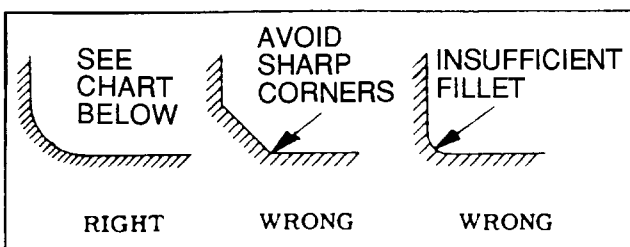

Replacing Bearing

CAMSHAFT

1. Remove the screws holding the camshaft thrust plate to the front of the cylinder block, which makes it possible to pull the camshaft forward out of the bearings.

2. Measure the camshaft bearing journals and bores.

If clearance is equal to or greater than the amount indicated under wear limits, check the diameter of the camshaft journals to determine the next step. Excess wear at these positions require replacement of the shaft.

3. If the front camshaft journal **bore** becomes worn beyond limits, there is a service camshaft bushing available as p/n F400G00222. (See SPB 89-389 for details.)

4. Tappets can then be lifted out and lined up in sequence, for installation in the same location unless inspection shows that they require replacement.

CAUTION: When installing camshaft use special care to prevent camshaft bumping and loosening expansion plug at rear of crankcase causing an oil leak.

TAPPETS

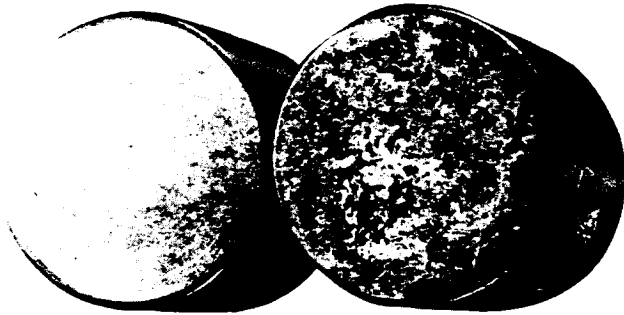

ACCEPTABLE

NOT ACCEPTABLE

Valve Tappet Wear Comparison

1. Inspect each tappet carefully. Two or three small pits on the contact face is acceptable; more than that calls for replacement of the tappet. A damaged tappet could mean possible damage to the camshaft.
2. Check the outside diameter with a micrometer to determine if replacement is necessary because of wear. Refer to limits and clearance section.

REAR CRANKSHAFT OIL SEALS

The overhead valve engines have the rear crankshaft oil seals incorporated in the combination rear main bearing cap and filler block.

The rear crankshaft oil seal has a stiffener ring imbedded in the rubber and no metal retainer is required.



Installing Seal in Rear Main Bearing Cap and Filler Block

The overhead valve engines have a good, trouble-free rear crankshaft oil seal — if carefully installed.

IMPORTANT: Installing rear oil seals correctly demands careful workmanship. Install seal with lip pointing toward engine.

Worn oil seals should be replaced in the following manner:

1. Remove rear bearing cap and filler block assembly by using a puller.

Remove old seals and thoroughly clean all contact surfaces.

2. Install crankshaft oil seals "A" — on engine block and main bearing cap.

Before installing — break edge "C" slightly on both cap and block to avoid cutting the seals during installation and coat seal edge "E", contacting the groove with sealing compound.

NOTE: This oil seal can be installed without removing the crankshaft — in this case, use only light grease in the seal groove to assist sliding the seal in place. Apply pressure to the seal so that it will hug the crankshaft which will also help moving it in place.

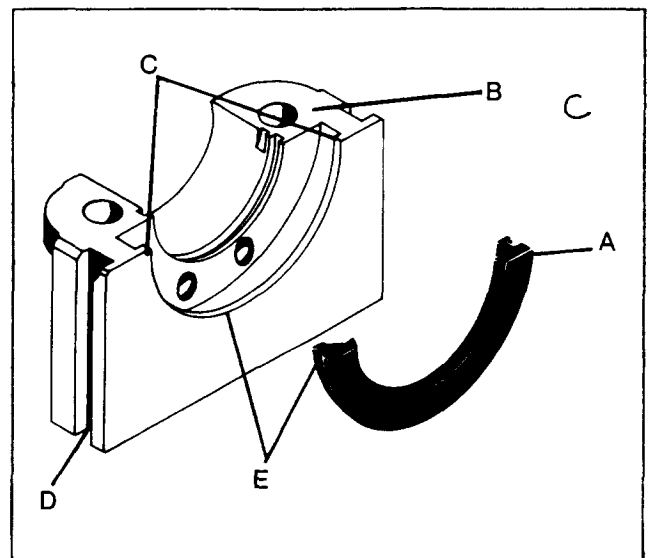

Filler Block and Seal



Crankshaft Oil Seal in Block

3. Apply a light coat of cement (national oil seal or EC-847) to the butting ends of the crankshaft oil seal halves. Allow to become tacky before assembling. Lightly coat the crankshaft contact edge of the seal with graphite grease to prevent damage prior to use.
4. Install Crankshaft.
5. Apply a light coating of RTV Gasket Material to surface "B" and graphite grease to the oil seal lip. Carefully install the combination rear bearing cap and filler block on to the dowels. Insert the capscrews and torque to 150-162 Nm (110-120 Lb. Ft.)



Applying RTV to Rear Filler Block

6. After the rear cap is in place and torqued, inject RTV into each side seal slot "D" as shown in illustration. Force the RTV into the channels until a steady flow comes out the corner chamfers.

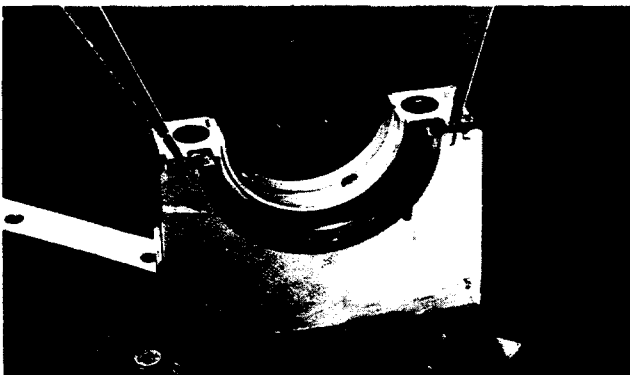

Installing RTV in Rear Filler Block Channels

NOTE: Oil leakage will occur if any voids are left along these slots.

7. Dip the curing insert in clean water. Install curing insert until approximately 5/8" protrudes from slot. Cut off flush with pan rail. This insert insures complete cure of the RTV.

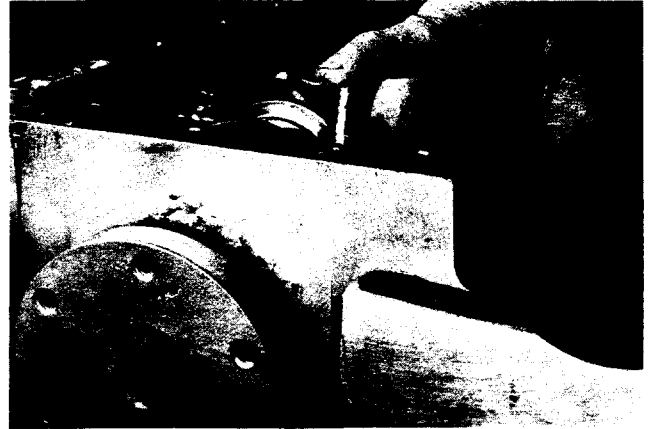

Install Curing Insert

8. Prior to installing oil pan, apply a small bead of RTV material to the rear bearing cap and filler block as shown. (See page 60.)

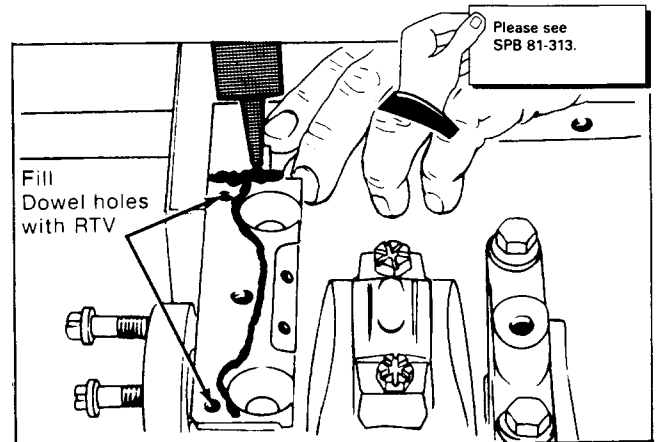

Applying RTV to Rear Bearing Cap and Filler Block

OIL PUMP

The oil pump is assembled to the front of the cylinder block and front main bearing cap and is held in place by capscrews.

The pump is driven by a hardened key mounted in the crankshaft.

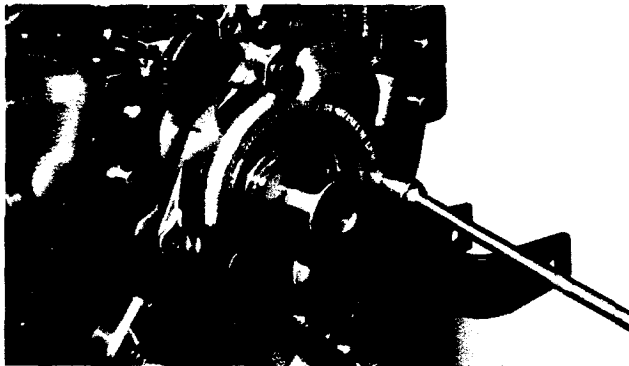
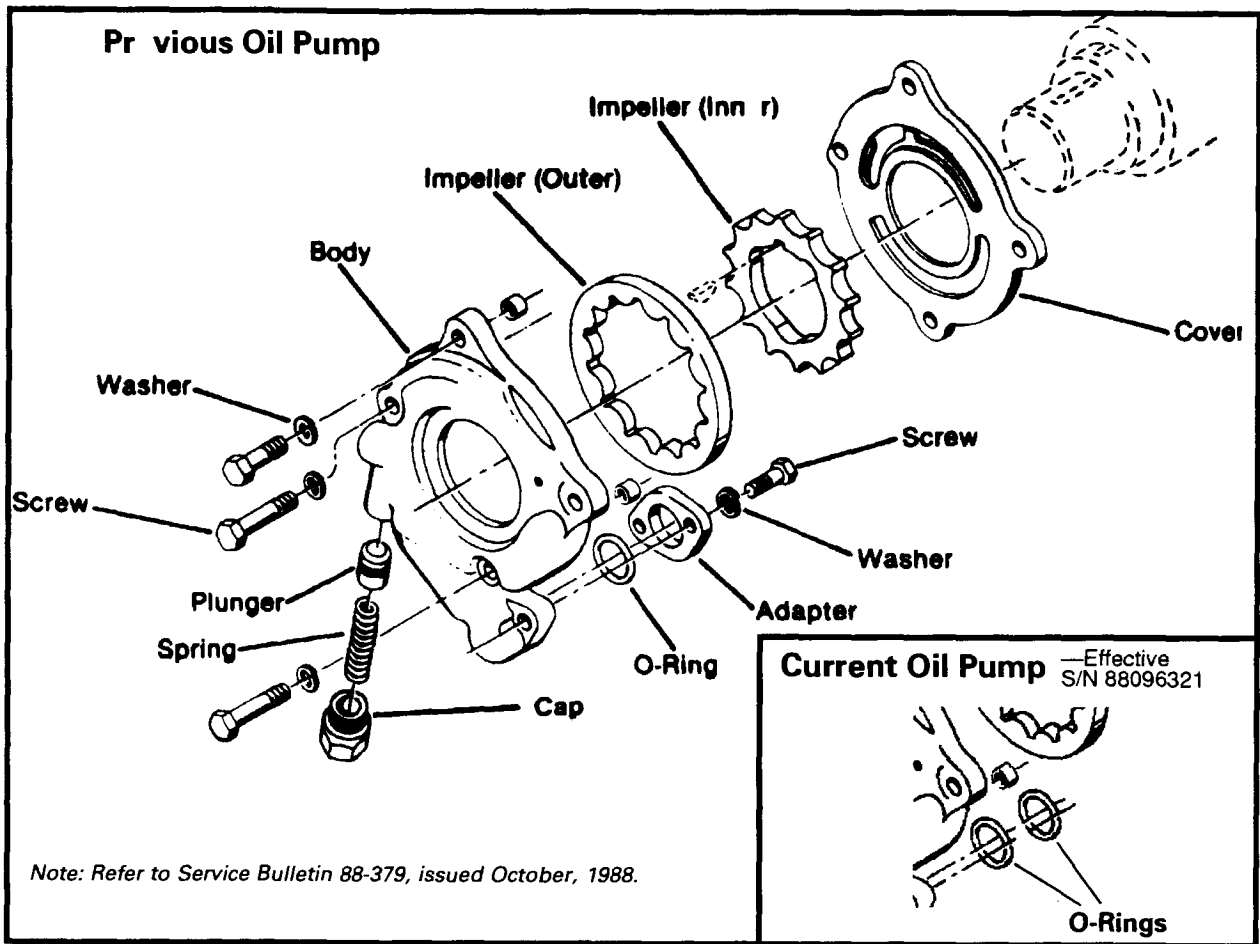

Oil Pump Removal



O-Ring at Pump Inlet

When the pump is removed and disassembled, examine the impellers, cover and cavity for wear; inspecting the key and keyway at the same time. If scored or worn badly they must be replaced.

Examine the pick-up screen for clogging or damage.

Examine the O-Ring at the pump inlet. If damaged, replace. **Two O-Rings are required after S/N 88096321.**

Engine oil pressure must be maintained to specification for satisfactory engine life.

The oil pump must be fully seated in the counterbore. No gaskets are used in this assembly.

Install mounting capscrews and tighten to 20-24 Nm (15-18 Lb. Ft.)

NOTE: When replacing any oil pumps on engines built before S/N 88096321, the oil suction tube must be replaced also. (See SPB 88-379.)

TIMING GEARS

1. Timing gears should be inspected for excessive wear and/or pitting and replaced if necessary.

2. Examine the camshaft thrust plate carefully for scoring and wear and if any indication of either shows, a new thrust plate should be assembled.



Camshaft Thrust Plate

3. Assemble the injection pump drive gear with key and cam gear to the camshaft by driving or pressing each on, at the same time holding the camshaft forward with suitable bar through the fuel pump opening in the block so there is no possibility of the camshaft bumping the expansion plug at the rear end and forcing it out of position, thus causing an oil leak.

NOTE: TMD20, spec. 8604 uses a different cam gear and injection pump drive gear set up. For assembly information see SPB 87-372.

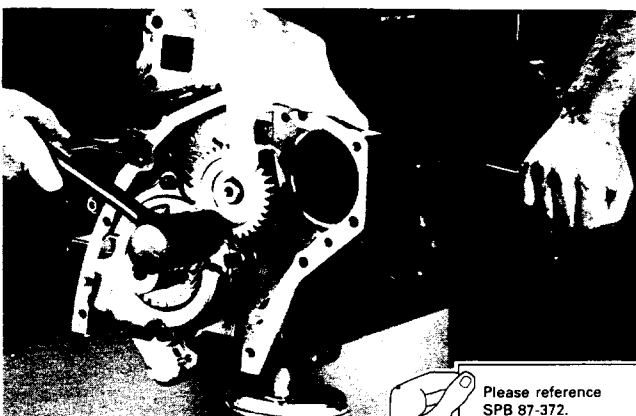

Installing Injection Pump Drive Gear

Please reference
SPB 87-372.

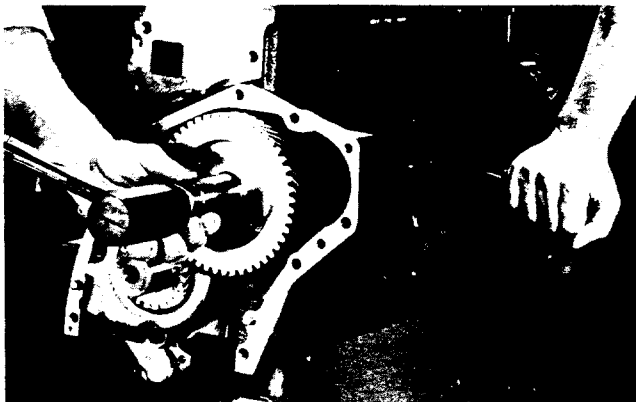

Installing Camshaft Gear

Assemble camshaft nut and torque to specification (see torque specifications section). Do not use impact wrench or over torque cam nut.



Torquing Cam Gear Nut

Check camshaft end play as shown in illustration. Refer to limits and clearance section for correct dimension.

CAUTION: NEVER USE THE CAMSHAFT NUT TO PRESS THE GEAR ONTO THE CAMSHAFT. This will break the threaded end off cast iron camshafts.

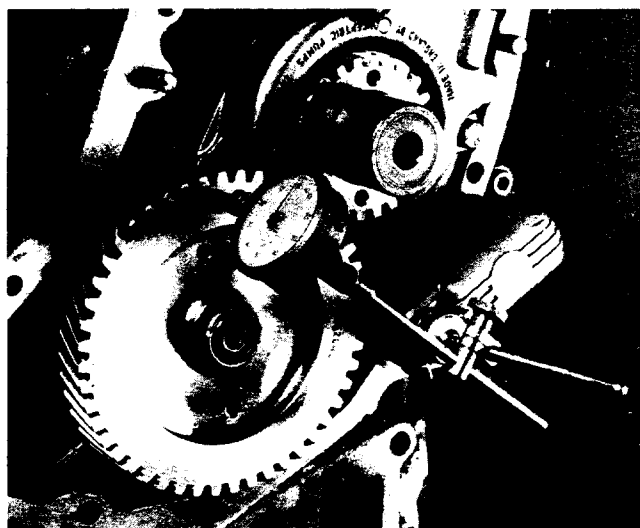

Checking Camshaft End Play

4. Drive the crank gear on the shaft making sure that the marked teeth on the cam gear straddle the marked tooth on the crank gear, which assures you of the crankshaft and camshaft being in time.

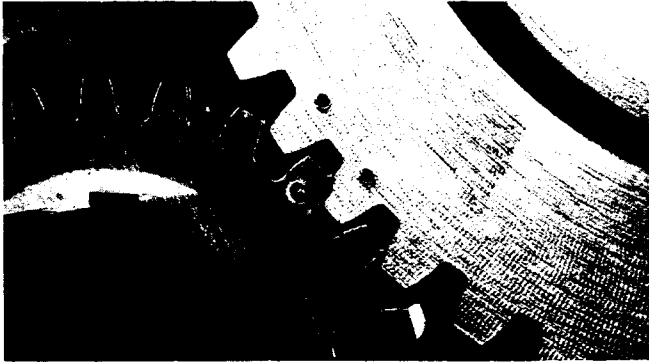

Timing Gears Assembled According to Timing Marks

CRANKSHAFT END PLAY

The crankshaft end play is controlled by the center flanged bearing. No shims are required. Using a dial indicator, check the crankshaft end play. If the end play exceeds 0.18mm (.007") replace the flanged bearing. End play should be between the 0.17mm (.0067") and 0.04mm (.0015") limits.

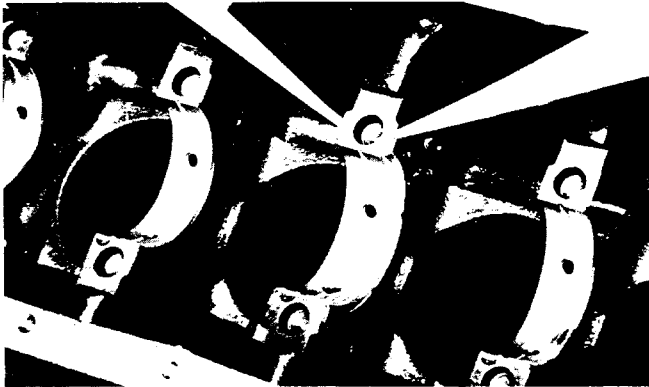

Flanged Bearing Controls Crankshaft End Play

FLYWHEEL AND FLYWHEEL HOUSING

Install flywheel housing using special cap screws.

NOTE: Special capscrews having sealing bands are used in the upper holes to mount the flywheel housing to the cylinder block. These special capscrews must be used to prevent oil leakage.

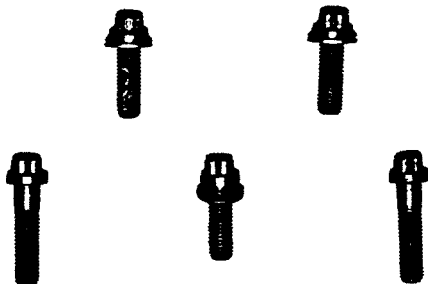

Special Capscrews

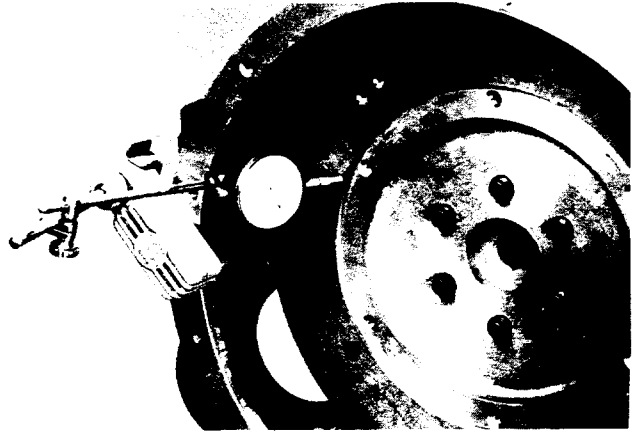

Checking Flywheel Run-Out

The flywheel is machined and balanced so that the clutch face and locating counterbore will run true with its axis.

Mount an indicator on the flywheel housing and check the flywheel for runout. Caution: When checking runout remove glow plugs to allow engine to be turned over freely.

The indicator should be set up so that it contacts the clutch face or the vertical surface of the clutch counterbore, then turn the flywheel at least one full revolution at the same time holding against the crankshaft to offset the possibility of end play.

Excessive runout of the flywheel, in either position, is probably caused by dirt in or damage to counterbore locating the flywheel on the crankshaft flange.

Re-locate the indicator to check the inside diameter of the counterbore. In both cases the maximum indicator reading must not be more than 0.20mm (.008").

When assembled, mount the indicator on the flywheel so that it contacts the housing face and turn the crankshaft, at the same time holding against it to counteract end play. The maximum indicator reading must not exceed 0.20mm (.008").



Checking flywheel Housing Face

Re-locate the indicator to contact the housing bore and check this in the same manner. The same runout limits prevail.

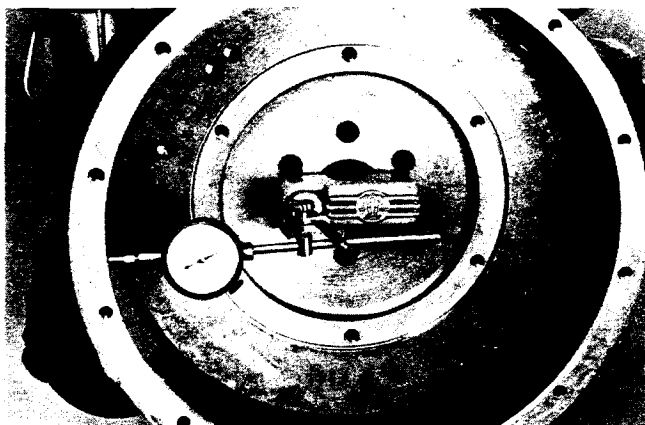

Checking Housing Bore

REASSEMBLING ENGINE

In the foregoing, we have outlined procedures for checking, repairing or replacing the many wearing parts in the engine.

In most cases, the instructions have covered the reassembly of parts or subassemblies made up of several parts.

When reassembling pistons and connecting rods, use a good ring compressor and oil the bores thoroughly. A hammer handle may be used to bump the pistons out of the ring compressor into the cylinder bore.

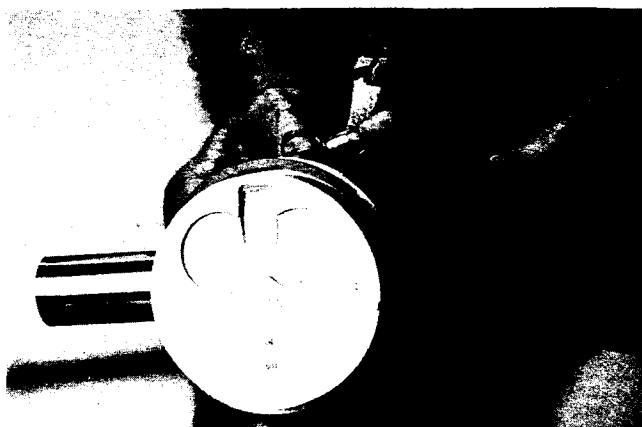

NOTE: The pistons have offset piston pins. Be sure to install pistons with notch or arrow in top toward the front of the engine.



Installing Pistons

Once more, we call attention to care demanded to prevent connecting rods damaging the cylinder bore finish and at the same time as they are assembled over the crank pin, locate them carefully in order to protect the bearing surfaces.

Always lubricate the bearings with clean engine oil when assembling, and tighten them to the torque specified.

INSTALLING HEAD

1. Make sure that gasket contact surfaces on the head and block are clean, smooth and flat. Check flatness with straight edge and feeler gauge in three positions lengthwise and five crosswise. The maximum permissible is 0.10mm (.004") low in the center lengthwise, gradually decreasing towards the ends, or 0.076mm (.003") crosswise or in localized low spots. If these limits are exceeded, replace the cylinder head.



Checking Cylinder Head Flatness Lengthwise



Checking Cylinder Head Flatness Crosswise

2. Install precombustion chamber inserts, making sure they are fully seated. Insert projection in reference with cylinder head surface is flush to 0.076mm (.003") projection.

Please see Procedure SPB 87-371.

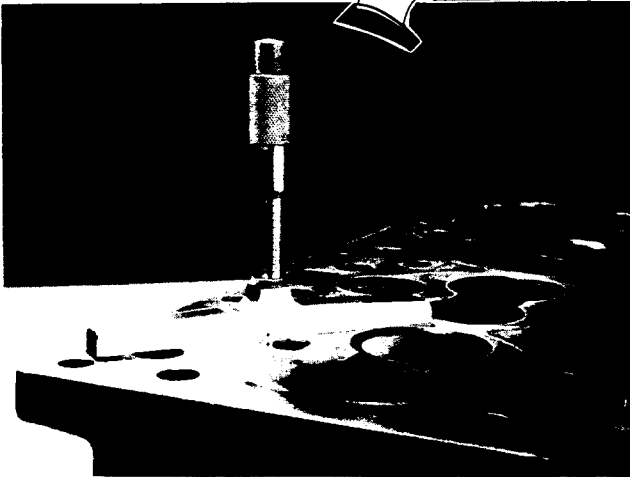

Precombustion Insert Projection

3. Use new cylinder head gasket, which is precoated, thus no cement is required.

4. Using a chain hoist, lower the cylinder head assembly evenly over the locator stud. Replace the locator stud with the proper cylinder head capscrew.

5. Before installing any head cap screws in the block, be sure the threads in the block and on the cap screws have been properly cleaned. Should these tapped holes need cleaning or reconditioning, care should be taken to use the proper tap.

Tap: M10 x 1.5 CLASS 6G
M12 x 1.75 CLASS 6G

6. The cylinder head capscrews require no sealant but should be installed with a **very light** coating of engine oil or lubriplate to reduce friction and insure proper clamp load and head



Torquing Cylinder Head Capscrews

capscrew torque. Tighten with torque wrench in recommended sequence to the correct torque shown in torque chart on page 68, *by going over them two times before pulling them down to the final torque specification on the third round.*

7. Install the injectors and glow plugs at this point. Having the injectors and glow plugs in now, eliminates the risk of dirt and foreign objects falling into the cylinder.



Installing Glow Plugs

NOTE: Always use new steel heat shield washers when installing injectors in cylinder head.

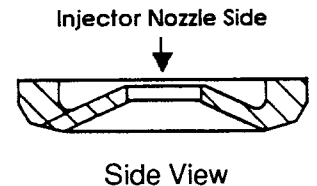

Installing Heat Shield and Injector

INSTALLING OIL PAN

Before assembling the oil pan, make sure the contact surfaces are flat and clean of any gasket material or oil.

A form-in-place gasket material is used for sealing the engine oil pan to the crankcase. The form-in-place gasket should be applied to the oil pan and filler blocks as shown here.

Tighten the screws in accordance with limits prescribed in the torque chart—to avoid looseness or overstressing. (See page 54.)

NOTES: 1. Parts must be assembled within 20 minutes after applying gasket material.
2. Caution must be used in handling the gasket materials. Read Labels.

When engine is completely assembled and filled with proper oil (see lubrication section), set tappets according to the following chart:

MODEL	INTAKE	EXHAUST
TMD	0.36mm (.014")	0.46mm (.018")

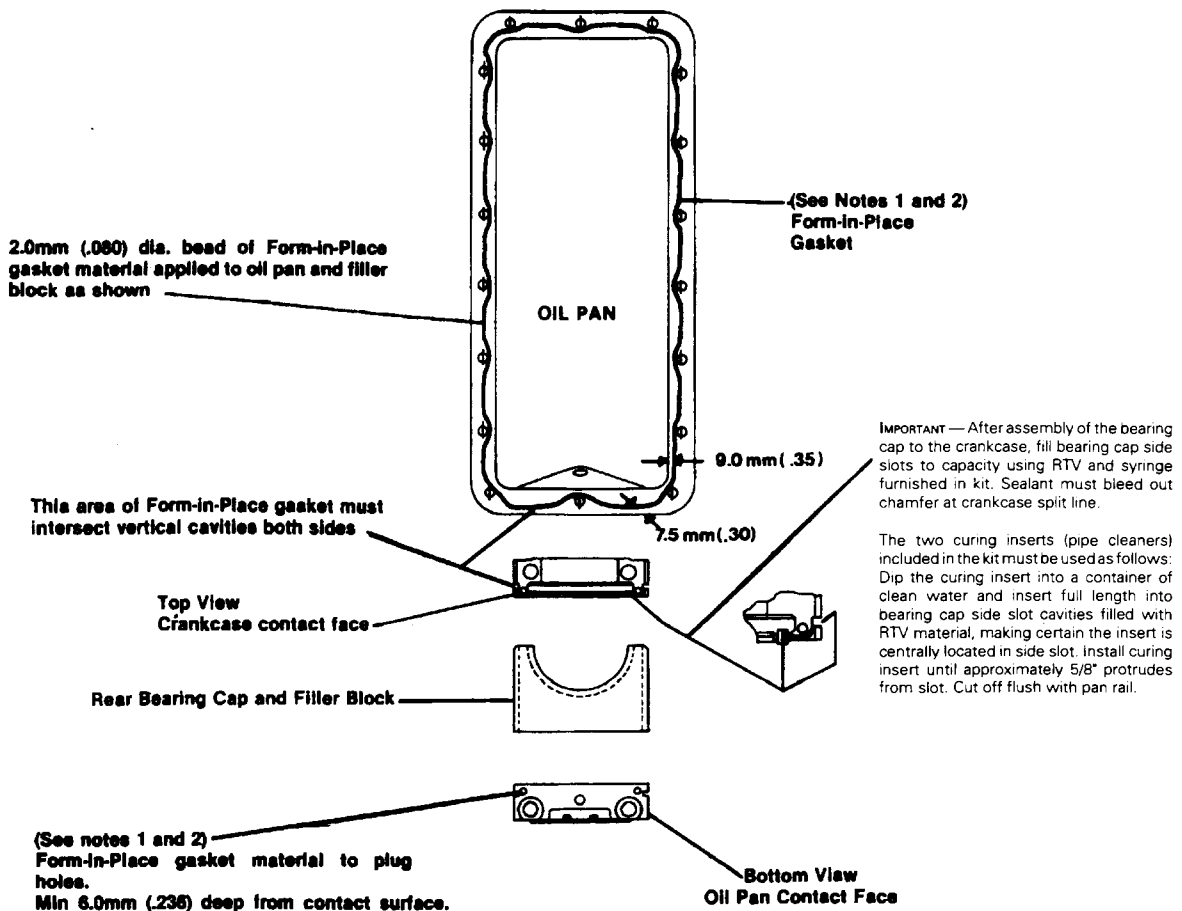

Typical RTV Oil Pan Application for the Diesel Overhead Valve Engine.

Section 9 - Trouble Shooting

WARNING

Bodily injury or death may result to individuals during operation of an engine within any enclosure not adequately or properly ventilated. Engine operation in any enclosure requires adequate and proper ventilation to avoid asphyxiation or other interruption of normal breathing, to supply sufficient air to cool the engine, provide air to mix with fuel and to carry away heated air from the building.

Read and observe safety warnings on pages 1 and 2.

A Preventive-Maintenance system including inspection, lubrication and adjustment as recommended in our Maintenance Section will prevent the greater portion of Diesel troubles.

Failure of a Diesel engine to perform satisfactorily is generally due to difficulties with the fuel supply system, such as air leaks in the suction line due to loose connections or restrictions to fuel flow because of clogged filters, rather than the injection pump or nozzles.

Any attempt to disassemble or repair fuel injection pumps must be made only by persons fully qualified and equipped.

Operators should depend on their well-developed senses of **feeling, hearing, seeing** and **smelling** and replace their sense of taste in this type of work — **with a generous amount of “Common Sense”**.

A good rule to follow in locating trouble is to never make more than **one** adjustment at a time—then locate the trouble by a process of elimination. Remember the cause is usually **Simple** — rather than mysterious and complicated.

Following are listed some of the normal complaints encountered in routine operation of all Diesel engines—the probable causes and the recommended steps required to correct the difficulty:

COMPLAINTS	PROBABLE CAUSE	CORRECTION
(A) Engine Won't Turn Over	1 — Dead or weak battery 2 — Inadequate battery capacity 3 — Poor ground connection 4 — Loose or faulty wiring connections. 5 — Starting switch faulty 6 — Starting motor defective 7 — Internal engine seizure	1 — Recharge or replace battery. 2 — Replace Battery. 3 — Inspect and tighten ground cable. 4 — Clean and tighten connections. 5 — Replace switch or relay. 6 — Check brushes, commutator, drive spring and mounting bolts. 7 — Turn engine manually — if unable to do this, check for foreign objects in gears, on top of piston or for piston seizure.

COMPLAINTS	PROBABLE CAUSE	CORRECTION
<p>(B) Engine Turns But Won't Start</p>	<p>1 — No Fuel Supply to Pump 2 — Air in Fuel Injection Lines</p> <p>3 — Clogged or dirty filters</p> <p>4 — Cranking speed low</p> <p>5 — Water in Diesel Fuel</p> <p>6 — Wrong injection pump timing</p> <p>7 — Low atmospheric temperature</p> <p>8 — Low compression</p> <p>9 — Glow plugs faulty or inoperative</p>	<p>1 — Fill Fuel Tank or open Shut-Off Valve. 2 — Check connections and bleed Fuel System. 3 — Disassemble and clean primary filter and replace secondary filter if clogged. 4 — Recharge or replace battery, check starter, repair if necessary. 5 — Drain Fuel System - Refill with clean fuel or strain through chamois and bleed system. 6 — Retime pump to engine according to recommendations. 7 — Use cold starting equipment —</p> <div data-bbox="981 669 1471 752" style="background-color: black; color: white; padding: 5px;">  WARNING </div> <p style="font-size: 0.8em; margin-top: 5px;">Starting fluids or aids such as ether or gasoline must not be used in a diesel engine air intake system. The use of these fluids will cause severe internal engine damage and/or bodily injury. Read and observe safety warnings on pages 1 and 2.</p> <hr style="border: 2px solid black; margin: 5px 0;"/> <p>8 — See recommendations in "G" 9 — Replace or correct.</p>
<p>(C) Runs "Rough" With Excessive Vibration</p>		<p>Note: A characteristic of a fuel injection pump is that if engine misfiring occurs, and it is traced to a certain cylinder in which no combustion is taking place, the cause might be an injector sticking open in the cylinder which immediately precedes that cylinder in the engine firing order.</p> <p>During injection to the cylinder which has the injector sticking in the open position, the fuel rushes into that cylinder with no restriction whatsoever, causing a scavenging effect in the pump distributor rotor and a void which cannot be recharged to a sufficient degree to provide opening pressure of fuel to the following injector. Hence, no combustion can take place. Please note this well, as knowledge of this characteristic might provide a great saving in service time in such a given situation.</p>

COMPLAINTS	PROBABLE CAUSE	CORRECTION
(C) Runs "Rough" with Excessive Vibration	1 — Misfiring cylinder or cylinders 2 — Too low operating temperature—below 165 °F 3 — Air in fuel lines 4 — Clogged air cleaner 5 — Engine idles too slowly 6 — Poor fuel	1 — Loosen fuel line to injector one at a time—no noticeable change indicates that cylinder is misfiring. Clean and test injector for pressure, leakage and pattern. 2 — Check thermostat. 3 — Check connections—Bleed fuel system. 4 — Clean and service air cleaner, tighten connections. 5 — Increase to recommended speed. 6 — Use Diesel engine fuel that meets specifications.
(D) Loss of Power	1 — Wrong injection pump timing 2 — Air in fuel lines 3 — Clogged or dirty filters 4 — Restriction in air flow 5 — Poor fuel 6 — Poor Compression 7 — Injection nozzles faulty 8 — Injection pump faulty	1 — Retime pump to engine according to recommendations. 2 — Check connections and bleed fuel system. 3 — Clean Primary Filter and replace secondary filter if necessary. 4 — Service Air Cleaner and Connections. 5 — Use recommended Diesel Engine Fuel that meets specifications (See Pages 11 & 29). 6 — See "G" recommendations. 7 — Clean and Test Faulty Nozzle for pressure leakage and spray pattern. 8 — Remove and have checked at an authorized service center.
(E) Overheating	1 — Lack of coolant. 2 — Fan belts slipping 3 — Overloading the engine 4 — Thermostats sticking or inoperative 5 — Fuel injection timing wrong 6 — Back pressure in exhaust line	1 — Add water. Tighten hose connections and repair leaks as required. 2 — Inspect belt condition and adjust tension. 3 — Reduce load. Keep engine speed up. 4 — Remove, clean and check thermostats and replace if required. 5 — Retime pump according to recommendation. 6 — Inspect for restriction in muffler and exhaust system, and clean.

COMPLAINTS	PROBABLE CAUSE	CORRECTION
<p>(F) Excessive Smoke</p>	<p>WHITE SMOKE — May Indicate Misfiring</p> <p>1 — Low engine temperature</p> <p>2 — Faulty injectors</p> <p>3 — Poor fuel</p> <p>4 — Poor compression</p> <p>5 — Coolant leaks into combustion chamber</p> <p>6 — Glow plugs not used at start-up</p> <p>BLUE SMOKE — Indicates High Oil Consumption</p> <p>1 — Worn or stuck rings</p> <p>2 — Low engine water temperature</p> <p>3 — Worn valve guide, valve stem or valve stem seal</p> <p>BLACK SMOKE</p> <p>1 — Excessive fuel rate</p> <p>2 — Overloading engine</p> <p>3 — Restriction in air supply</p> <p>4 — Low engine water temperature</p>	<p>1 — Check thermostat — increase engine temperature.</p> <p>2 — Cut out individual injectors with engine running — clean and test faulty nozzle for pressure, leakage and spray pattern.</p> <p>3 — Use Diesel fuel that meets specifications. (See Pages 11 & 29)</p> <p>4 — See "G" recommendations.</p> <p>5 — Check head gasket.</p> <p>6 — Energize glow plugs before starting.</p> <p>1 — See (I) high oil consumption recommendation.</p> <p>2 — Check thermostat.</p> <p>3 — Replace</p> <p>1 — Take pump to an authorized service center.</p> <p>2 — Reduce load.</p> <p>3 — Clean air cleaner.</p> <p>4 — Check thermostat.</p>
<p>(G) Poor Compression (Under 325# at 150 RPM)</p>	<p>1 — Valves holding open — no tappet clearance</p> <p>2 — Leaky cylinder head gasket</p> <p>3 — Wrong valve timing</p> <p>4 — Burned or sticking valves or incorrect valve timing</p> <p>5 — Broken or weak valve springs</p> <p>6 — Piston rings worn or broken</p> <p>7 — Worn pistons and bores</p>	<p>1 — Adjust tappet clearance to specifications.</p> <p>2 — Clean head and block surfaces. Replace gasket and torque to Specification. (See Torque Specification Section 10.)</p> <p>3 — Check and correct if necessary.</p> <p>4 — Clean and grind valves. Reface or replace as required.</p> <p>5 — Check and replace any not up to specifications.</p> <p>6 — Re-ring with recommended service kit.</p> <p>7 — If necessary rebore & replace pistons. (See SPB 87-371 — check for cylinder head warpage.)</p>

COMPLAINTS	PROBABLE CAUSE	CORRECTION
(H) Low Oil Pressure	<ul style="list-style-type: none"> 1 — Low oil level 2 — Oil pressure gauge or line faulty 3 — Oil too light—diluted 4 — Dirt in relief valve or broken spring 5 — Suction screen plugged 6 — Worn bearings 7 — Worn oil pump 8 — Pick-up tube O-ring damaged or missing 	<ul style="list-style-type: none"> 1 — Add oil to dipstick level. 2 — Inspect lines and check with Master Gauge. 3 — Change oil and follow recommended lubrication. 4 — Clean or replace spring. 5 — Remove screen and clean in solvent. 6 — Replace 7 — Remove, repair or replace pump. 8 — Replace
(I) High Oil Consumption	<ul style="list-style-type: none"> 1 — Oil leaks 2 — Too high oil level maintained 3 — Incorrect grade of oil used 4 — Clogged crankcase breather 5 — Oil pressure too high—relief valve stuck 6 — Piston rings not properly run-in 7 — Worn, broken or stuck piston rings and clogged oil control rings 8 — Worn pistons or bores 9 — Worn bearings and valve guides 10 — Intake valve seals 	<ul style="list-style-type: none"> 1 — Locate and repair. 2 — Maintain oil level between high and low marks on dip stick. 3 — Use recommended type and SAE number of lubricating oil. 4 — Clean thoroughly. 5 — Clean and free up valve—check spring tension. 6 — Break in all new and rebuilt engines as recommended. 7 — Re-ring with recommended service rings. 8 — If necessary rebore & replace pistons 9 — Replace 10 — Replace
(J) Poor Fuel Economy	<ul style="list-style-type: none"> 1 — Operating with low coolant temperature 2 — Wrong fuel 3 — Loss of power 4 — Incorrect injection pump timing 5 — Nozzles faulty 6 — Incorrect tappet clearance 	<ul style="list-style-type: none"> 1 — Maintain 79.4°C-85°C (175°F-185°F) for maximum economy and performance. 2 — Use Diesel fuel that meets specifications. 3 — Follow "D" recommendations. 4 — Follow recommended timing procedure. 5 — Cut out faulty injector—clean and test for pressure, leakage and spray pattern. 6 — Adjust tappets .46 (.018) exh. and .36 (.014) int. (Reference page 60)

COMPLAINTS	PROBABLE CAUSE	CORRECTION
(K) Sudden Stopping	1 — No fuel 2 — Restriction in fuel flow 3 — Air in fuel lines 4 — Transfer pump faulty 5 — Water in fuel 6 — Internal engine seizure 7 — Faulty electrical shut-off on injection pump	1 — Refill fuel tank and bleed fuel system. 2 — Clogged or dirty filters—check lines for obstruction or break. 3 — Bleed fuel system. 4 — Replace transfer pump. 5 — Drain system and refill with clean fuel or strain remaining fuel through chamois. 6 — Turn engine manually—if unable to do so check for foreign object in combustion chamber or for piston or bearing seizure. 7 — Repair or replace
(L) Engine Knocks and Noises	COMBUSTION KNOCKS (Excessive) 1 — “Lugging” 2 — Poor quality fuel 3 — Injection timed too early 4 — Injection nozzle sticking	1 — Reduce load or increase speed. 2 — Use only #2 diesel engine fuel oil for good performance and economy. 3 — Follow recommended timing procedure. 4 — Remove nozzle, check opening pressure, clean and adjust.
	MECHANICAL KNOCKS 1 — To locate knock 2 — Main bearings 3 — Connecting rod bearings 4 — Loose piston pin 5 — Broken piston ring or pin 6 — Tappet noise 7 — Timing gear noise	1 — “Short out cylinders” by loosening fuel line to nozzle one at a time—if no change in sound, knock is not occurring in that cylinder. 2 — Heavy, dull knock when accelerating under load. Examine bearing lining for wear or excessive clearance. Replace if necessary. 3 — Condition noted at idle or light load and disappears at full load. Check and correct as in Para. 2, main bearings. 4 — Sharp metallic rap at idling speed or when starting cold. Replace pin with oversize. 5 — Sharp, clicking noise that cannot be eliminated by shorting out. Remove pistons, replace piston pin or rings if necessary. 6 — Check tappet clearance. Adjust to specifications. (Reference page 60) 7 — Loose or worn-gears rattle; tight-gears whine. Check gear fit and examine teeth. Refit new set of gears if loose or worn badly.

Section 10-Torque Specifications

NOTE: The following Torque Values are based on Phosphate Coated Fasteners (Class 10.9 & 12.9) and Black Oxide Coated Fasteners (Class 8.8 & 9.8).

CYLINDER HEAD

ENGINE SERIES	SEE CHART
TMD	Page 68

ITEM	THD SIZE	MAT'L CLASS	TORQUE	
			N-m	LB.FT.
Connecting Rods CAUTION: High limit is maximum. DO NOT Torque beyond high limit.	3/8	SAE GR 8	61-68	45-50
Main Bearing Caps	M14	12.9	150-162	110-120
Flywheels	M10	12.9	68-75	50-55
Flywheel Housings Rear End Plates	M10	12.9	61-68	45-50
Manifolds (Seezpruf)	M8	8.8/9.8	20-24	15-18
	M10	8.8/9.8	34-40	25-30
Gear Covers Water Pumps	M10	8.8/9.8	34-40	25-30
Oil Pans (Sheet Steel)	M8	9.8	14-19	10-14
Oil Pump To Engine	M8	8.8/9.8	20-24	15-18
Rocker Shaft Supports	M8	8.8/9.8	23-27	17-20
Accessories And Misc. Brackets	M6	8.8/9.8	8-11	6-8
	M8	8.8/9.8	20-24	15-18
	M10	8.8/9.8	34-40	25-30
	M12	8.8/9.8	75-81	55-60
	M14	8.8/9.8	122-135	90-100
Camshaft Nuts (cast iron camshaft)	7/8		88-95	65-70
Crankshaft Pulley	M16	8.8	163-176	120-130
Glow Plugs	M12		31-38	23-28
Nozzle To Holder	M22		68-75	50-55
Fuel Injection Pump Driven Gear To Fuel Injection Pump	5/16	8	27-34	20-25
*Injector to Cylinder Head	M24		68-75	50-55
Rocker Cover	M8	9.8	7-8	5-6
High Pressure Fuel Lines	M12		27-34	20-25

*Always use a new steel heat shield washer between injector and cylinder head.

NOTE: The Following Torque Values are to be used only if Torque Value for specific part to be installed is not listed on preceding sheets.

THD SIZE	TORQUE (Phosphate Coated Fasteners)					
	Class 8.8		Class 9.8		Class 10.9	
	N·m	LB.FT.	N·m	LB.FT.	N·m	LB.FT.
M6	8-11	6-8	8-11	6-8		
M8	20-24	15-18	20-24	15-18		
M10	34-40	25-30	34-40	25-30		
M12	75-81	55-60	75-81	55-60		
M14	122-135	90-100	122-135	90-100		
M16	190-203	140-150	190-203	140-150		
M20						

PROPERTY CLASS MARKING

BOLTS AND SCREWS:

The property class symbols for metric bolts and screws are given in table at right. Marking shall be located on the top of the head. Alternatively, the marking may be indented on the side of the head for hex head products.

STUDS:

All metric studs used on TMD engines are of property class 10.9. If marked, marking will be at nut end.

PROPERTY CLASS	IDENTIFICATION SYMBOL	
	BOLTS, SCREWS AND STUDS	STUDS SMALLER THAN M12
8.8	8.8	○
9.8	9.8	+
10.9	10.9	□
12.9	12.9	△

CYLINDER HEAD

TORQUE SEQUENCE

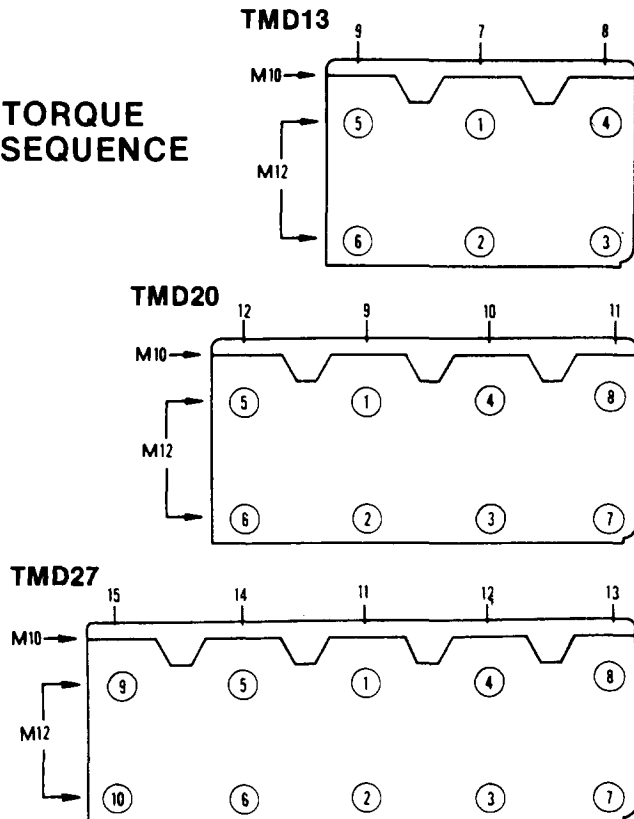

Cold Torquing Procedure

Step 1. Torque with Hand Torque Wrench to:

Screw Size	Ft.Lbs.	N·m
(SH) M12	30-35	41-47
(HH) M10	10-15	14-20
(HH) M12	25-30	34-41

Step 2. Torque with Hand Torque Wrench to:

Screw Size	Ft.Lbs.	N·m
(SH) M12	60-65	81-88
(HH) M10	20-25	27-34
(HH) M12	55-60	75-81

Step 3. Torque with Hand Torque Wrench in one single smooth motion:

Screw Size	Ft.Lbs.	N·m
(SH) M12	95-100	129-136
(HH) M10	35-40	47-54
(HH) M12	90-95	122-129

Hot Retorquing Procedure

Step 4. Retorque with Hand Torque Wrench (after engine reaches normal operating temperature) to the following values, in one single smooth motion:

Screw Size	Ft.Lbs.	N·m
(SH) M12	85-90	115-122
(HH) M10	30-35	41-47
(HH) M12	80-85	108-115

NOTE: (SH) = Socket Head Cap Screw (HH) = Hex Head Cap Screw



Torque all cylinder head capscrews using the proper torquing sequence shown here.

Section 11 - Limits and Clearance Data

NOTE: Dimensions shown are for standard engines.

ENGINE MODEL VALVE GUIDE (Intake & Exhaust)	TMD METRIC	(ENGLISH)
Length	60.4	(2 3/8)
Outside Dia.	16.700/16.675	(.6575/.6565)
Stem. Hole Dia.	8.717/8.692	(.3432/.3422)
*Wear Limits—Max. Dia.	8.775	(.3447)
VALVES, INTAKE		
Stem Dia.	8.660/8.642	(.3409/.3402)
*Wear Limits, Min. Dia.	8.592	(.3383)
Seat Angle	29°45'	(29°45')
Stem Clearance Limits	0.075/0.032	(.0030/.0012)
*Wear Limits—Max. Cl.	0.125	(.0049)
Desired Stem Clear.	0.053	(.0021)
VALVES, EXHAUST		
Stem Dia.	8.640/8.622	(.3402/.3394)
*Wear Limits—Min. Dia.	8.575	(.3376)
Seat Angle	44°45'	(44°45')
Stem Clearance—Limits	0.095/0.052	(.0037/.0020)
*Wear Limits—Max. Cl.	0.142	(.0056)
Desired Stem Clear.	0.073	(.0029)
VALVE SPRINGS		
Outside Dia.	34.85	(1.372)
Length—Valve Closed	42.0	(1.6535)
Load—Valve Closed	24KgF	(52.8#)
*Wear Limits—Min. Wgt.	21.5KgF	(47.3#)
Length—Valve open	32.88	(1.294)
Load—Valve open	47.54KgF	(104.6#)
*Wear Limits—Min. Wgt.	42.5KgF	(93.5#)

ENGINE MODEL CAMSHAFT	TMD METRIC	(ENGLISH)
Brg. Journal Dia. #1	47.511/47.486	(1.8705/1.8695)
#2	44.336/44.311	(1.7455/1.7445)
#3	42.749/42.723	(1.6830/1.6820)
*Wear Limits—Min. Dia.	0.025 (.001) Under Minimum New Shaft Diameter	
Bore—Inside Dia. #1	47.625/47.600	(1.8750/1.8740)
#2	44.450/44.425	(1.7500/1.7490)
#3	42.862/42.837	(1.6875/1.6865)
Bore—Clearance Limits End Play	0.139/0.089 0.038/0.178	(.0055/.0035) (.0015/.0070)
CONNECTING RODS		
Bush. Hole Dia.	30.175/30.150	(1.1880/1.1870)
Brg. Hole Dia.	52.375/52.362	(2.0620/2.0615)
Brg. Thickness	1.567/1.554	(.0617/.0612)
*Wear Limits—Min. Thk.	1.542	(.0607)
Dia.—Crank Pin	49.212/49.187	(1.9375/1.9365)
*Wear Limits—Min. Dia.	49.162	(1.9355)
Clearance Limits	0.080/0.016	(.0031/.0006)
Disired Clearance	0.048	(.0019)
*Wear Limits—Max. Cl.	0.091	(.0036)
Side Play	0.28/0.15	(.011/.006)
Desired Side Play	0.20	(.008)
MAIN BEARINGS		
Dia. of Brg. Bore in Block	78.019/78.00	(3.0716/3.0709)
Brg. Thickness	2.484/2.471	(.0978/.0973)
*Wear Limits—Min. Thk.	2.459	(.0968)
Dia. of Main Brg. Jr.	72.974/72.944	(2.8730/2.8718)
*Wear Limits—Min. Dia.	72.918	(2.8708)
Clearance Limits	0.133/0.058	(.0052/.0023)
Desired Clearance	0.096	(.0038)
C/S End Play	0.17/0.04	(.0067/.0015)
PISTON PIN		
Length	71.0/70.7	(2.795/2.783)
Diameter	28.575/28.571	(1.1250/1.1248)
*Wear Limits—Min. Dia.	28.562	(1.1245)
Desired Fit	Light Push	
Bush. Hole Dia.—Fin.	28.598/28.588	(1.1259/1.1255)
*Wear Limits—Max. Dia.	28.623	(1.1269)
Pin Cl. in Bushing	0.013/0.028	(0.0005/0.0011)
Desired Pin Fit	0.020	0.0008
TAPPET		
Outside Dia.	25.324/25.311	(.9970/.9965)
Bore in Block	25.364/25.344	(.9986/.9978)
*Wear Limits	0.13	(.005)

ENGINE MODEL	TMD	
PISTONS	METRIC	(ENGLISH)
Cylinder Dia.	91.039/91.000	(3.5842/3.5827)
*Wear Limits—Cyl. Bore	0.20	(.008)
Piston Pin Hole Dia.	28.583/28.578	(1.1253/1.1251)
Ring Groove Width—#1	2.560/2.540	(.1008/.1000)
Max. Wear Limit Width	2.611	(1.028)
Ring Groove Width #2—	2.060/2.040	(.0811/.0803)
*Max Wear		
Limit Width #2—	2.111	(.0831)
Ring Groove Width #3	4.060/4.040	(.1598/.1591)
*Max Wear Limit Width	4.109	(.1618)
Piston Fit-Feeler Gauge	0.08	(.003)
Lbs. Pull	2.3-4.5Kg	(5-10#)
PISTON RINGS		
Ring Width—#1	2.490/2.478	(.0980/.0976)
*Wear Limits—Min. Width	2.423	(.0954)
Ring Width—#2	1.990/1.978	(.0783/.0779)
*Wear Limits—Min. Width	1.923	(.0757)
Ring Width #3	3.990/3.978	(.1571/.1566)
Wear Limits—Min. Width	3.927	(.1546)
Ring Gap Clear—#1	0.40/0.65	(.016/.026)
Ring Gap Clear—#2	0.40/0.65	(.016/.026)
Ring Gap Clear—#3	0.30/0.60	(.012/.024)
Ring Side Clear—#1	0.082/0.050	(.0032/.0020)
Ring Side Clear—#2	0.082/0.050	(.0032/.0020)
Ring Side Clear—#3	0.082/0.050	(.0032/.0020)

NOTES

Index

WARNING

Read and observe all individual safety warnings as you use this manual to operate, service or repair your engine. See pages 1 and 2.

Important Safety Notice and Warnings	1 & 2
Contents	3
Industrial Continental Diesel Specifications	4
SECTION 1 - General Information	
Continental Diesel Engine	5
SECTION 2 - Operating Instructions	
Preparation of a New Engine for Operation	7
Starting the Engine	7
Stopping the Engine	9
11 "Musts"	9
Cold Weather Operation	9
Engine Preparation for Winter Use	10
Preparation of Engine for Seasonal Storage	11
SECTION 3 - Lubrication	
Engine Lubrication System	13
Oil Pump	13
Oil Change Frequency	13
Lubrication Recommendations	14
SECTION 4 - Cooling System	
Cooling System	15
Effect of Altitude on Cooling	16
Anti-Freezes	16
Cleaning Cooling System	16
Testing Thermostat	17
Radiator Pressure Cap	18
Fan Belt Tension	18
Water Pump	19
SECTION 5 - Fuel System	
Electric Fuel Transfer Pump	21
Bleeding the Fuel System	22
Fuel Filters	23
Injectors	24
Testing	24
Fuel Injection Pump	25
Timing of Injection Pump to the Engine	26
Fuel Recommendations	31
SECTION 6 - Charging System	
Charging System	32

SECTION 7 - Preventive Maintenance

Daily Preventive Maintenance Schedule 34
Dry Type Replaceable Air Filter 34
PCV System 35
Check Oil Pressure 35
50 - Hour Preventive Maintenance Schedule 36
250 - Hour Preventive Maintenance Schedule 37
400 - Hour Preventive Maintenance Schedule 37
500 - Hour Preventive Maintenance Schedule 37

SECTION 8 - Engine Repair and Overhaul

Cylinder Head 39
Disassembly of Cylinder Head 40
Valve Guides 41
Valve Seat Inserts (if supplied) 41
Valve Guide Data 42
Valves 43
Valve Springs 44
Rocker Arms 45
Valve Push Rods 45
Checking Bore Wear 45
Preparing Cylinder Walls for Re-Ringing or Reboring 45
Pistons 47
Piston Pins 48
Connecting Rod 48
Piston and Connecting Rod Assembly 48
Piston Rings 49
Recommended Method of Installing Piston Rings 49
Crankshaft and Main Bearings 50
Bearings 50
Camshaft 52
Tappets 53
Rear Crankshaft Oil Seals 53
Oil Pump 54
Timing Gears 55
Crankshaft End Play 57
Flywheel and Flywheel Housing 57
Reassembling Engine 58
Installing Head 58
Installing Oil Pan 60

SECTION 9 - Trouble Shooting

Engine Won't Turn Over 61
Engine Turns, but Won't Start 62
Runs "Rough" with Excessive Vibration 62
Loss of Power 63
Overheating 63
Excessive Smoke 64
Poor Compression (under 325# at 150 RPM) 64
Low Oil Pressure 65
High Oil Consumption 65
Poor Fuel Economy 65
Sudden Stopping 66
Engine Knocks and Noises 66

SECTION 10 - Torque Specifications 67-68

SECTION 11 - Limits and Clearance Data 69-70

SERVICE AND PARTS
Available from your Authorized
WISCONSIN
Service Center



California Proposition 65

The engine exhaust from this product contains chemicals known to the State of California to cause cancer, birth defects or other reproductive harm.



WISCONSIN
MOTORS, LLC

SALES OFFICE:

2020 Fletcher Creek Drive, Memphis, Tennessee 38133

Phone: (901) 371-0353 or Toll Free (800) 932-2858

www.wisconsinmotors.com