

WISCONSIN

**30.0 HP GASOLINE
DUAL FUEL, LPG &
NG OPTIONS**

VH4D

YOUR HEAVY-DUTY SOURCE OF POWER

Setting industry Standards since 1909, Wisconsin continues to offer you a wide selection of air-cooled gasoline engines. Five models allow you to choose from single-cylinder, twin-cylinder and four-cylinder engines with power ranging from 7.0 to 65.9 HP.

WISCONSIN CONSTRUCTION

Wisconsin Engines are designed for those tough applications that require durability and long life reliability. The multi-cylinder, v-block design offers unique side load capability for a wide variety of industrial applications.



STANDARD FEATURES

- 4-Cylinder
- Air-Cooled
- V-Block Configuration
- Forged-Steel Crankshaft with Tapered Roller Main Bearings
- Heavy-Duty Cast-Iron Block
- Cast Iron Cylinders
- Centrifugal Flyweight Governor
- Aluminum Alloy Pistons
- Heat Resistant Alloy Steel Exhaust Valves
- Instrument Panel
- Replaceable Valve Seat Inserts
- Solid State Ignition
- Exhaust Valve Rotators

WORLDWIDE PARTS & SERVICE

We back our engines with a worldwide service network. Experienced Wisconsin representatives are always ready to meet your needs.



WISCONSIN MOTORS, LLC

WISCONSIN

30.0 HP GASOLINE DUAL FUEL, LPG & NG OPTIONS

VH4D

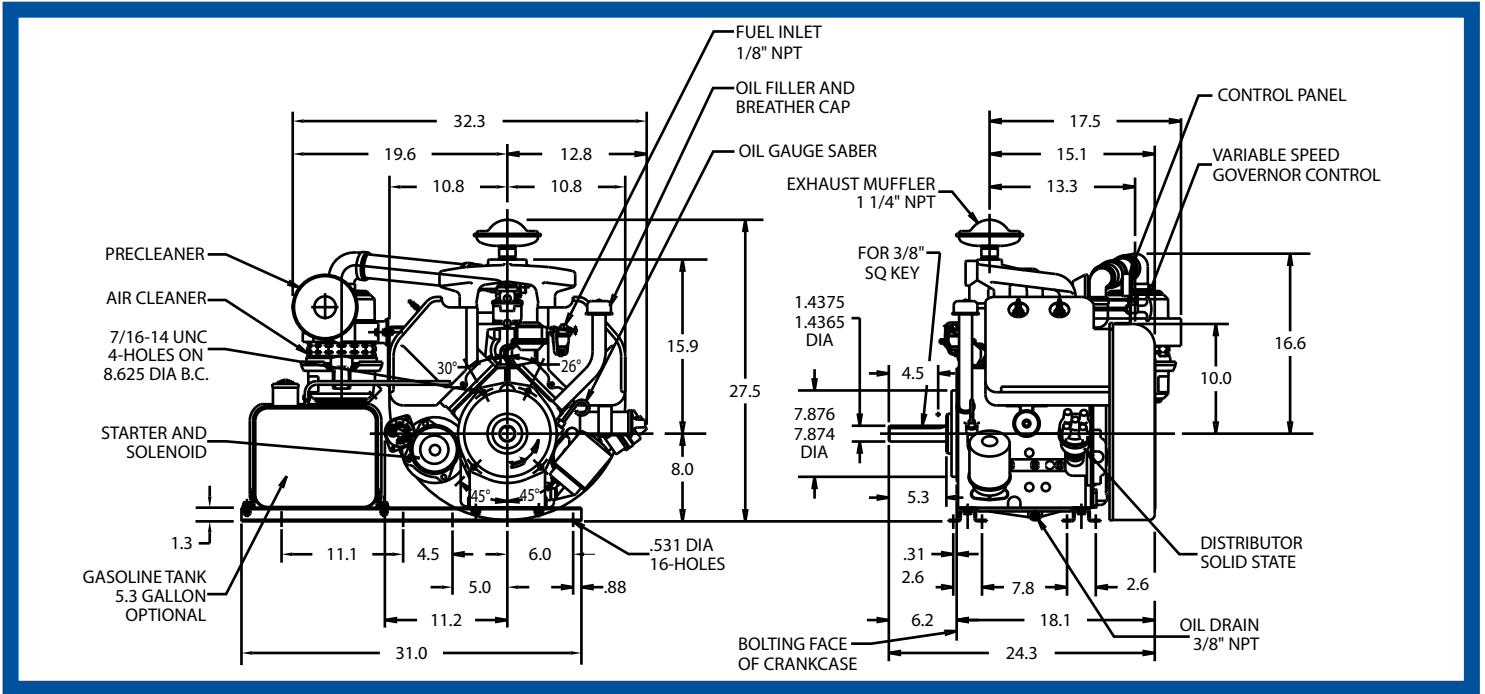

* Net Weight Dry Standard Engine 530 lbs. (240 kg)

Bore 3.25 in. (82.6 mm)
Stroke 3.25 in. (82.6 mm)
Displacement 107.7 cu. in. (1765 cc)

RPM	HP	KW	TORQUE	
			Ft. lbs	Kg-m
1400	17.2	12.8	62.0	8.9
1600	20.0	14.9	65.8	9.1
1800	22.5	16.8	65.7	9.1
2000	24.7	18.4	64.8	9.0
2200	26.5	19.8	63.2	8.7
2400	28.0	20.9	61.2	8.5
2600	29.2	21.8	59.0	8.1
2800	30.0	22.4	56.2	7.8

POWER OUTPUT

Maximum dynamometer net brake horsepower of the basic engine corrected to a pressure reading of 29.31 in. Hg (99 KPA) dry barometer and temperature of 77° F (25° C) when tested in accordance with SAE Test Code J1349. Engine output can be demonstrated within 5% at the factory under standard rating conditions. Power will decrease 3.5% for each 1000 ft. (305 M) above 500 ft. and 1% for each 10° F above standard temperature of 77° F (25° C). For continuous operation, applications should be limited to 80% of power shown.

OPTIONS FOR EVERY NEED

- Air Cleaner (Dry Element Tri-Phase)
- Bell Housings (SAE #4&5)
- Clutch Take-Off
- Clutch Reduction Assemblies (In Ratios of 2,3, or 4 to 1 with Clockwise or Counter-Clockwise Take-Off Shaft Rotation)
- Heavy-Duty Mufflers
- High-Temperature Safety Switch
- Accessory Drive for Hydraulic Pump
- Special Crankshaft Extensions & Stub Shafts
- 12 volt, 30 amp Flywheel Alternator
- 65 amp Belt-Driven Alternator

* Contact your Wisconsin Representative for Additional Options

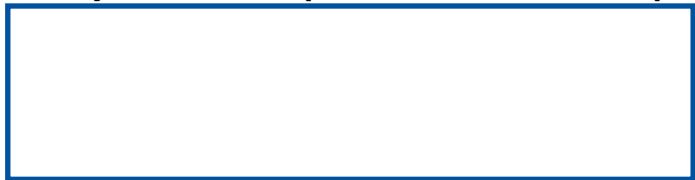

WISCONSIN MOTORS, LLC

SALES OFFICE:

2020 Fletcher Creek Dr. • Memphis, TN, 38133
 Phone (901) 371-0353 • Toll Free 800-932-2858

www.wisconsinmotors.com