

INSTRUCTION BOOK

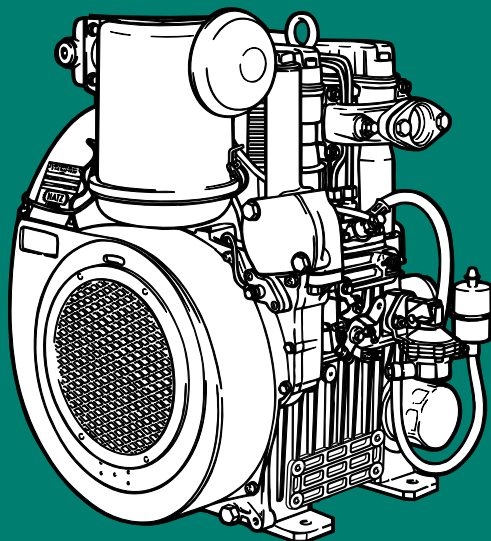

INCLUDES SUPPLEMENTAL INFORMATION TO THE
OWNER'S MANUAL FOR 2008 AND LATER EPA CERTIFIED
NONROAD COMPRESSION-IGNITION ENGINES

INCLUDES SUPPLEMENTAL INFORMATION TO THE
OWNER'S MANUAL FOR 2008 AND LATER CALIFORNIA
REGULATIONS FOR HEAVY-DUTY OFF-ROAD ENGINES



2G40 2G40 H

433 316 05-USA-EPA IV-CARB

12.07-0.05

Printed in Germany

A new HATZ Diesel engine - working for you

This engine is intended only for the purpose determined and tested by the manufacturer of the equipment in which it is installed. Using it in any other manner contravenes the intended purpose. For danger and damage due to this, Motorenfabrik HATZ assumes no liability. The risk is with the user only.

Use of this engine in the intended manner presupposes compliance with the maintenance and repair instructions laid down for it. Noncompliance leads to engine breakdown.

Please do not fail to read this operating manual before starting the engine. This will help you to avoid accidents, ensure that you operate the engine correctly and assist you in complying with the maintenance intervals in order to ensure long-lasting, reliable performance.

Please follow all maintenance references carefully including the schedule for 2008 and later EPA certified nonroad compression-ignition engines or for 2008 and later California certified Heavy-Duty off-road engines to prevent our environment.

Please pass this Instruction Manual on to the next user or to the following engine owner.



The worldwide **HATZ Service Network** is at your disposal to advise you, supply with spare parts and undertake servicing work.

You will find the address of your nearest **HATZ service station** in the enclosed list.



Original - Ersatzteile

Original-spare parts

Pièces de rechange d'origine

Repuestos originales

Use only **original spare parts from HATZ**. Only these parts guarantee a perfect dimensional stability and quality. The order numbers can be found in the enclosed spare parts list. Please note the spare part kits shown in Table 1.

We reserve the right to make modifications in the course of technical progress.

MOTORENFABRIK HATZ GMBH & CO KG

Contents

	Page
1. Important notes on safe operation of the engine	3
2. Description of the engine	5
3. General information	6
3.1. Technical data	6
3.2. Transport	7
3.3. Instructions for installation	7
3.4. Load on engine	7
3.5. EPA/CARB-type plates	8
3.6. Emission-related installation instructions	9
4. Operation	9
4.1. Before initial start-up	9
4.2. Starting the engine	11
4.3. Stopping the engine	13
5. Maintenance	14
5.1. Maintenance summary	14
5.2. Maintenance every 8 – 15 hours of operation	16
5.3. Maintenance every 250 hours of operation	17
5.4. Maintenance every 500 hours of operation	21
6. Functional test	23
6.1. Air filter maintenance indicators	23
7. Malfunctions – Causes – Remedies	24
8. Work on the electrical system	27
9. Protective treatment	27
SUPPLEMENTAL INFORMATION TO THE OWNER'S MANUAL FOR 2008 AND LATER EPA CERTIFIED NONROAD COMPRESSION IGNITION ENGINES	29
SUPPLEMENTAL INFORMATION TO THE OWNER'S MANUAL FOR 2008 MODEL YEAR AND LATER CALIFORNIA REGULATIONS FOR HEAVY-DUTY OFF-ROAD ENGINES	43



This symbol identifies important safety precautions.

Please comply with these most carefully in order to avoid any risk of injury to persons or damage to materials.

General legal requirements and safety regulations issued by the competent authorities or industrial accident insurers are also applicable.

1. Important notes on safe operation of the engine



HATZ diesel engines are economical, strongly built and long-lasting. They are therefore frequently chosen for commercially and industrially operated equipment and machinery.

Since the engine forms part of the finished equipment or machine, its manufacturer will take all the applicable safety regulations into account.

Nevertheless, we give below certain additional comments on operating safety, and would recommend you to note them carefully.

Depend on the manner in which the engine is installed and its intended application, the equipment manufacturer or operator may have to attach additional safety devices and prohibit potentially hazardous aspects of operation, for example:

- Exhaust system components as well as the surface of the engine will naturally be hot and must not be touched while the engine is running or until it has cooled down after being stopped.
- Faulty wiring or incorrect operation of electrical equipment may lead to sparks forming, and must be avoided as a potential fire hazard.
- Rotating parts must be shielded against accidental contact when the engine is installed in other equipment or machinery.
Guards are available from HATZ to protect belt drives to cooling fans and generators.
- Before attempting to start the engine it is essential to have studied the starting information in the instruction book.
- Mechanical starting devices must not be used by children or persons of insufficient physical strength.
- Before starting the engine, ensure that all the specified protective guards are in place.
- The engine must only be operated, serviced or repaired by persons who have received the appropriate training.
- Keep the ignition key out of reach of unauthorized persons.
- Do not run the engine in closed or badly ventilated rooms.
Do not breathe in emissions – danger of poisoning!
- Also fuel and lubricants could contain poisonous components. Please follow the instructions of the mineral oil producer.

Important notes on safe operation of the engine



- Stop the engine before performing any maintenance, cleaning- or repair work.
- Stop the engine before refuelling.
Never add fuel near a naked flame or a source of sparks.
Don't smoke. Don't spill fuel.
- Keep explosive materials as well as flammable materials away from the engine because the exhaust gets very hot during operation.
- Wear close-fitting clothing when working on a running engine.
Please don't wear necklaces, bracelets or any other things which you could get caught with.
- Please pay attention to all advice- and warning stickers placed on the engine and keep them in legible condition. Contact your next HATZ Servicestation, if a sticker comes off or is illegible and ask for a new one.
- Note that any unauthorized modification to the engine absolves its manufacturer from liability for the consequences.

Regular servicing in accordance with the details provided in this Instruction Book is essential to keep the operating reliably and to ensure the exhaust quality of the engine.

In case of doubt, always consult your nearest **HATZ service station** before starting the engine.

2. Description of the engine

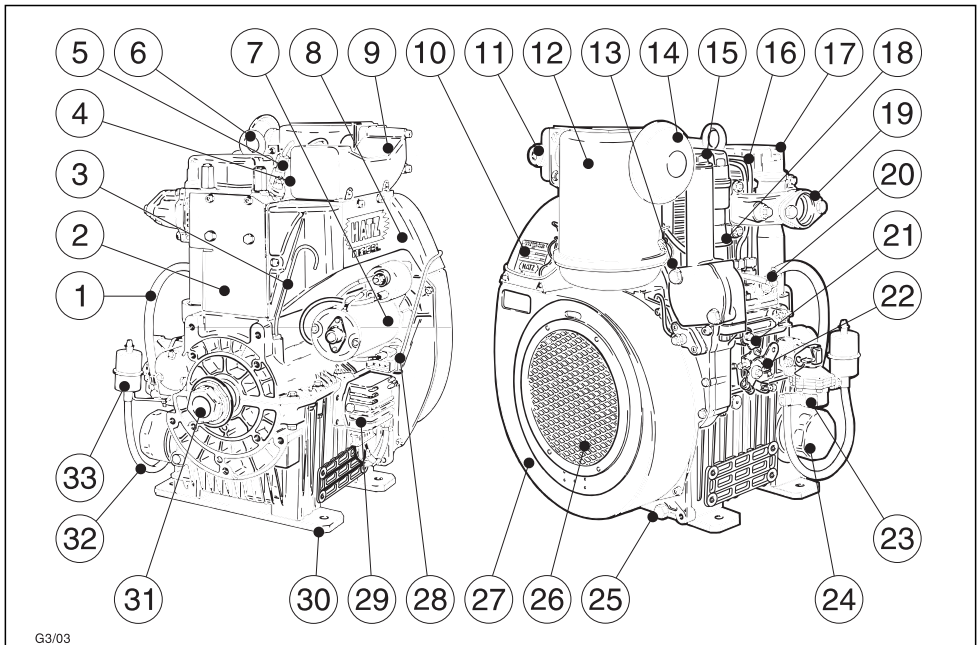

Fig. 1

1 Fuel line (feed pump – fuel-injection pump)	12 Oilbath air cleaner	25 Oil drain plug
2 Air deflector	13 Oil pressure switch	26 Guard
3 Oil dipstick	14 Rainproof cap	27 Air guide housing
4 Fuel return line	15 Oil filler cap	28 Separable connector
5 Injector	16 Fuel pressure pipe	29 Voltage regulator
6 Lifting eyebolt	17 Cylinder head cover	30 Engine mount
7 Starter motor	18 Engine oil line	31 Crankshaft, power-take-off
8 Air guide	19 Exhaust manifold	32 Fuel line (fuel filter - feed pump)
9 Air intake pipe	20 Fuel injection pump	33 Fuel filter
10 Type plate	21 Stop lever	
11 Glow plug (additional equipment)	22 Speed control lever	
	23 Fuel feed pump	
	24 Engine oil filter	

3. General remarks

3.1. Technical data

Type		2G40 / 2G40H			
Design		Air-cooled four-stroke diesel engine			
Combustion system		Direct injection			
Number of cylinders		2			
Bore/stroke	mm	92 / 75			
Displacement	cm ³	997			
Engine oil content incl. filter renewal	l. approx.	2.5 excl. sump ¹⁾ 3.0 incl. sump ¹⁾			
Difference between „max“ and „min“ levels	l. approx.	0.8 ¹⁾			
Engine oil pressure	min.	1 bar at 900 r.p.m. engine speed			
Engine oil consumption (after running-in period)	approx.	1% of fuel consumption at full load			
Direction of rotation, power take-off end		anti-clockwise			
Valve clearances at 10 - 30 °C Inlet/exhaust	mm	0.10			
Max. permissible perm. inclination Angle of inclination in ° without oil sump with oil sump		Exhaust		Flywheel	
		low	high	low	high
		30 ²⁾	17 ²⁾	25 ²⁾	25 ²⁾
		30 ²⁾	17 ²⁾	30 ²⁾	25 ²⁾
Weight (incl. fuel tank, air-cleaner, exhaust silencer and electric starter)	kg approx.	106			
Battery capacity	Amp/h	max. 12V / 88Ah – 24V / 88Ah			

¹⁾ These values are intended as an approximate guide. The **max.** marking „3“ on the dipstick is the determining factor, Fig. 6.

²⁾ Exceeding these limits causes engine breakdown.

3.2. Transport

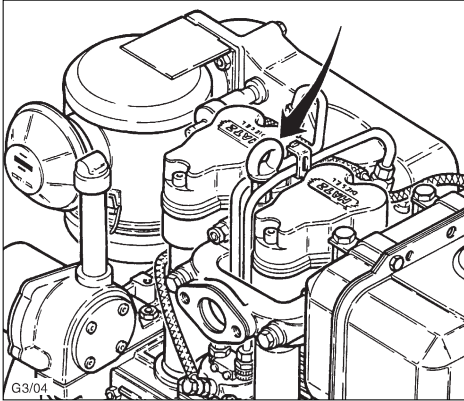

2

! The lifting eyebolt provided as standard equipment is intended for safe movement of the engine with its auxiliaries. Its maximum load capacity is 150 kg. It is not intended for lifting complete machinery to which the engine is attached, and this is strictly forbidden.

3.3. Instructions for installation

The „Manual for Selection and Installation of Engines“ contains all the information you need if your engine has not yet been installed on or in the equipment it is intended to drive, or set up in its correct operating position.

You can obtain a copy of this manual from your nearest **HATZ service station**.

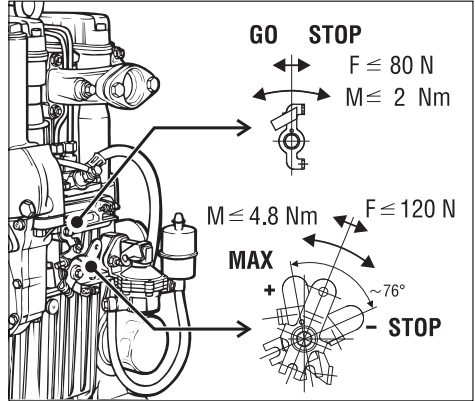

3

! The permitted loads and elements on the speed adjusting lever and the stop lever should be observed as an excess can lead to damage to the contacts and inner governor parts.

3.4. Load on engine

See supplemental information for EPA certified engines, Page 29; resp. supplemental information for California regulations for off road engines, Page 43.

3.5. EPA/CARB-type plates and fuel label

There are two EPA/CARB- type plates applied for the identification of the engine. The type plates are placed on the air guide (chapt. 2). They include the following emission control information (Figure 4a):

Label 1/2

EMISSION CONTROL INFORMATION
MOTORENFABRIK HATZ KG - D-94099 RUHSTORF
 ENG.FAM. MADE IN GERMANY
 ①
 TYPE / SPEC. / FDT **HATZ DIESEL**
 ②
 SERIAL NO. CM³ / PV Label 1/2
 ③ ⑥
 MIN⁻¹ NH / kW BUILD DATE
 ④ ⑦ ⑤
 THIS ENGINE COMPLIES WITH US EPA REGULATIONS FOR MY
 NONROAD DIESEL ENGINES AND CALIFORNIA REGULATIONS FOR MY
 OFF-ROAD DIESEL ENGINES. REFER TO OWNER'S MANUAL FOR
 MAINTENANCE SPECIFICATIONS AND ADJUSTMENTS.
 EC-TYPE NO.
 CONSTANT-SPEED ONLY ⑧ VARIABLE SPEED ⑨

4a

- ① EPA/CARB- Engine Family Number
- ② engine type/spec. (only for special equipment) /Fuel Delivery Timing
- ③ engine number
- ④ max. engine rated speed
- ⑤ build date
- ⑥ displacement
- ⑦ rated power
- ⑧ “constant speed only” (if requested)
- ⑨ “variable speed” (if requested)

Every engine is equipped with an additional loose engine type plate. If the original type plate on the engine is not readily visible after the engine is installed in the equipment then the second loose type plate must be attached on the equipment in such a manner that it is readily visible to an average person.

For any offer as well as spare parts orders it is necessary to mention the following data (also see spare parts list, page 1):

- ② engine type/spec.
(only for special equipment)
- ③ engine number
- ④ max. engine rated speed

The layout is identical for constant-speed and variable speed application.

Attention:

If the engine was certified for constant-speed application and shall be used so, the field “constant-speed only” is marked with “X”.
 If the engine was certified for variable speed application and shall be used so, the field “variable speed” is marked with “X”.

Always install the engine for its intended application in order to comply with EPA and CARB emission regulation requirements.

Label 2/2

EMISSION CONTROL INFORMATION
LOW SULFUR FUEL OR
ULTRA LOW SULFUR FUEL ONLY
Power category:
 < 8 kW / 8-19kW / 19-37kW /
 37-56 kW *PM Standard: 0.3 g/kWh*
 Label 2/2

4b

The engine must be operated with “LOW SULFUR FUEL OR ULTRA LOW SULFUR FUEL ONLY”.

The label also states the applicable emission-related power category of the engine.

Fuel label

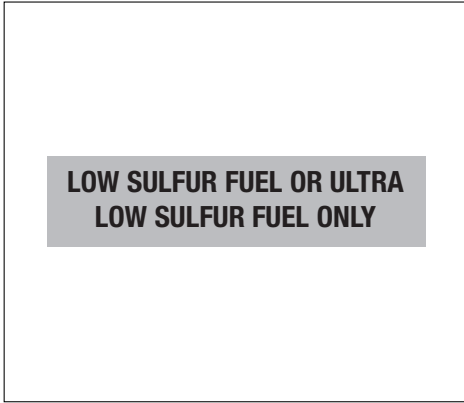

4c

The fuel label is placed nearby the fuel inlet. If there was no fuel tank mounted to the engine, the label has to be permanently attached to the equipment near the fuel inlet.

3.6. EMISSION-RELATED INSTALLATION INSTRUCTIONS

See supplemental information for EPA certified engines, Page 29; resp. supplemental information for California regulations for off road engines, Page 43.

4. Operation

4.1. Before initial start-up

Engines are normally delivered without fuel and oil.

4.1.1. Engine oil

Oil quality

Qualified are all trademark oils which fulfil at least one of the following specifications:

ACEA – B2 / E2 or more significant

API – CD / CE / CF / CF-4 / CG-4 or more significant.

If engine oil of a poorer quality is used, reduce oil change intervals to 150 hours of operation.

Oil viscosity

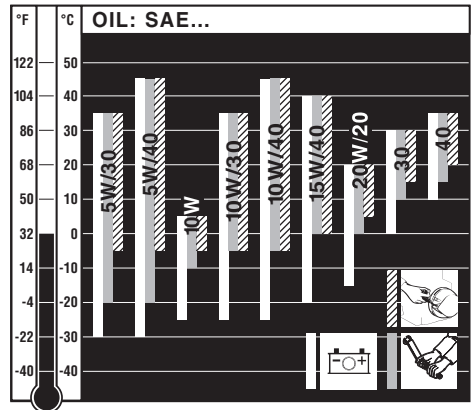

5

Choose an engine oil with a viscosity category that matches the ambient temperature when starting from cold.

When adding oil or checking the level, the engine must be in a horizontal position.

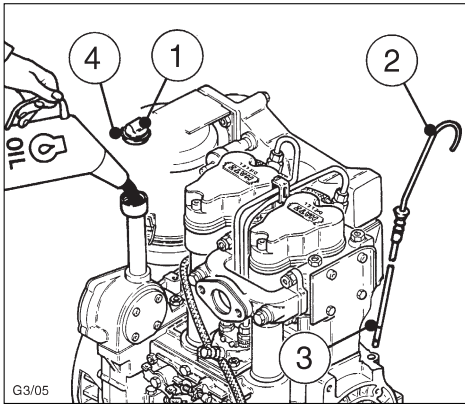

6

- Remove oil filler screw „1“ and dipstick „2“.
- Add engine oil until the level reaches upper mark „3“ on the dipstick (fig. 6, chap. 3.1.).
- Insert the oil filler screw and tighten it (hand-tight only).
- After a short test run, check engine oil level again and correct if necessary.

4.1.2. Oilbath air cleaner

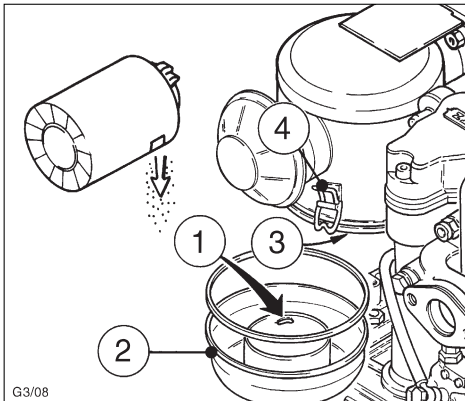

7

If a cyclone-type dust trap is fitted, make sure that the dust outlet is pointing in the correct direction (fig. 7).

- Fill the oil tank up to mark „1“ with engine oil.
- Attach oil tank „2“, making sure that sealing ring „3“ is correctly seated and clips „4“ are fastened securely.

4.1.3. Fuel

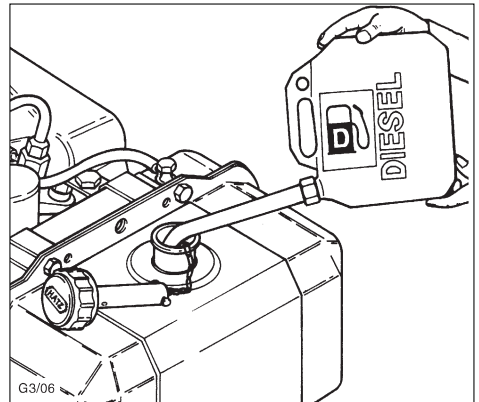

8



Stop the engine before refuelling. Never add fuel near a naked flame or a source of sparks. Don't smoke. Use only pure fuel and clean filling equipment. Take care not to spill fuel.

Diesel fuel complying with the minimum requirements of the following specifications may be used:

**EN 590 or
DIN 51601 - DK or
BS 2869 A1 / A2 or
ASTM D 975 - 1D/2D**

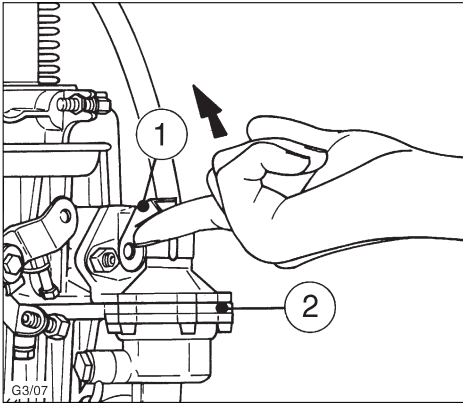

9

Before starting for the first time or if the fuel system was run dry, prime it by operating lever „1“ on feed pump „2“ until fuel is heard to flow back into the fuel tank through the return line.

At temperatures below 0 °C, winter-grade fuel should be used or paraffin added to the fuel well in advance.

Lowest ambient temperature when starting, in °C	Paraffin content for:	
	Summer fuel	Winter fuel
0 up to -10	20 %	–
-10 up to -15	30 %	–
-15 up to -20	50 %	20 %
-20 up to -30	–	50 %

4.2. Starting the engine



Do not run the engine in closed or badly ventilated rooms – danger of poisoning!

Before starting the engine, make sure that no one is within the danger area near the engine or the machinery it is driving, and that all the necessary guards are installed.

4.2.1. Preparations for starting

- If possible, disengage the engine from any driven equipment
The auxiliary equipment should always be placed in neutral.

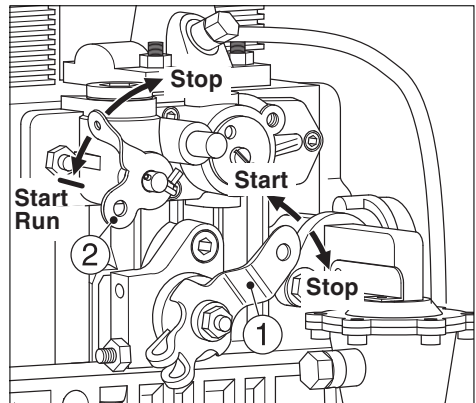

10

- Depending on operation conditions and requirements, set speed control lever „1“ to either the 1/2 START or max. START position.
- Make sure that stop lever „2“ is in the off position „START“.



L3/250

11



Never use starting aids in the form of aerosols or sprays!

4.2.2. Electric starter

– For starting preparations, see Chapter 4.2.1.

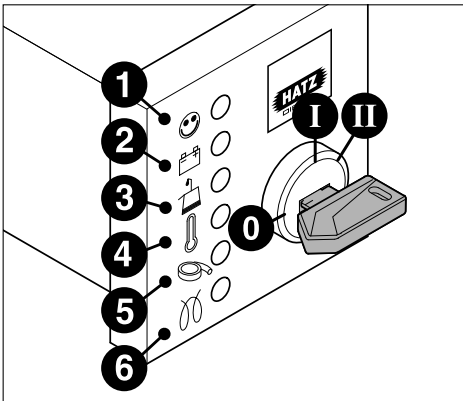

12

- Insert the key **to its stop** and turn it to **position I**.
- Battery charge telltale „2“ and oil pressure warning „3“ must light up.
- Turn start key to **position II**.

- As soon as the engine runs, release the start key. It must return to **position I** by itself and remain in this position during operation. The battery charge telltale and oil pressure warning must go out immediately after starting. Indicator light „1“ is on when the engine is in operation.
- The engine temperature display „4“ (additional equipment) lights up if the temperature at the cylinder head becomes too high.
Switch off the engine and trace and eliminate the cause of the problem, see chapter 7.
- The air cleaner maintenance indicator „5“ (additional equipment) only lights up during operation if the air cleaner element needs to be cleaned or renewed (see Chapter 5.4.2.).
- Always turn the start key back to **position 0** before re-starting the engine. The repeat lock in the ignition lock prevents the starter motor from engaging and possibly being damaged while the engine is still running.

Important!

If a starter protection module is fitted, the key must be turned back to **position 0** for at least 8 seconds if the engine fails to start, before a second attempt of starting can be made.

Preheating device with automatic heating timer (additional equipment)

The preheating light „6“ lights up additionally at temperatures below 0° Celsius (Fig. 12).

- After the light has gone out, start the engine without delay.

4.3. Stopping the engine

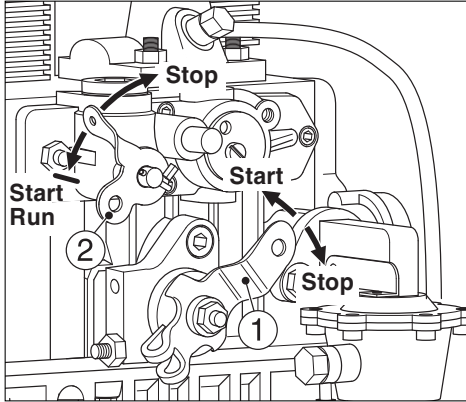

13

- Move speed control lever „1“ back to the „STOP“ position.
- On engines with the lower idling speed out of use, move speed control lever „1“ back, then move stop lever „2“ towards STOP and hold it there until the engine has come to a standstill.
- After the engine has ceased to run, release stop lever „2“, making sure that it returns to its original „START“ position.

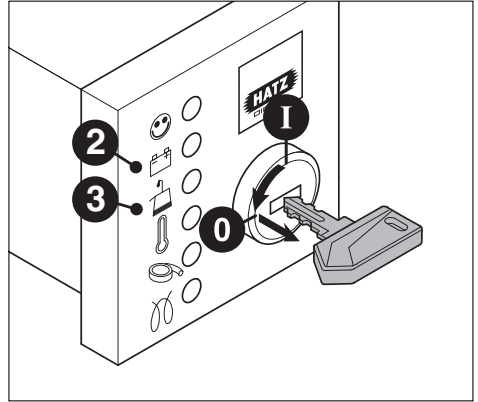

14

The charge **2** and oil pressure pilot lamps **3** come on.

- Turn the ignition key to the **0 position** and pull it out. The pilot lamp lights must then go out.

Note:

Engines with an automatic electrical shutdown system can also be stopped by turning the ignition key back to **positon „0“**.



During breaks in operation or at the end of the work session, pull out the ignition key and keep in a safe place where it cannot be reached by unauthorized persons.

5. Maintenance



The engine must be stopped before any maintenance work is attempted.
Comply with legal requirements when handling and disposing of old oil, filters and cleaning materials.

Keep the engine's key and starting handle out of reach of unauthorized persons.

To immobilize engines with an electric starter, disconnect the negative battery terminal.

At the end of the maintenance work, check that all tools have been removed from the engine and all safety guards, covers etc. replaced in their correct positions.

Before starting the engine, make sure that no-one is in the danger area (engine or driven machinery).

5.1. Maintenance summary

	Maintenance interval	Maintenance work required	Chap.
	Every 8 – 15 operating hours or before daily starting	Check oil level.	5.2.1.
		Check area around combustion air input.	5.2.2.
		Check cooling air system.	5.2.3.
		Check that the oil level in the lower part of the oil bath air cleaner is correct and that the oil is not contaminated.	4.1.2.
			5.3.1.
	Every 250 operating hours	Maintenance of air filter/oil bath air filter.	5.3.1.
		Replace engine oil and oil filter.	5.3.2.
		Check and adjust valve clearances.	5.3.3.
		Clean cooling air system.	5.3.4.
		Examine screw connections.	5.3.5.
	Every 500 operation hours	Renew fuel filter.	5.4.1.
		Maintenance of air filter/dry-air filter	5.4.2.

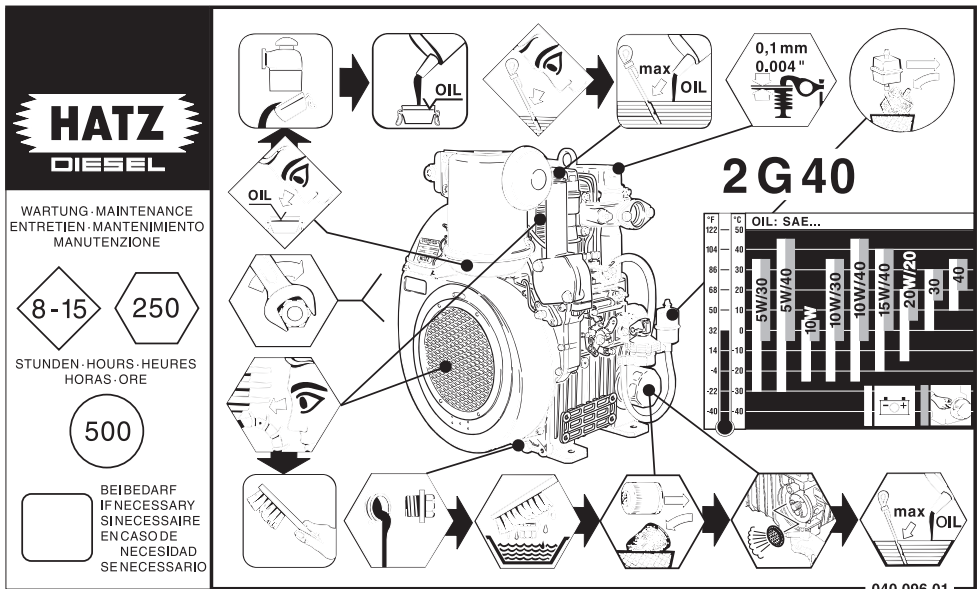

The above maintenance chart is supplied with every engine. This label should be affixed to the engine or equipment in an easily visible position. The maintenance chart governs the maintenance intervals.

For **new or reconditioned engines**, the following must always be carried out after the **first 25 operating hours**.

- Replace engine oil and oil filter, chap. 5.3.2.
- Check tappet clearance, and adjust if necessary, chap. 5.3.3.
- Examine screw connections, chap. 5.3.5.

For **short operating periods**: replace engine oil and oil filter **after 12 months at the latest**, regardless of the number of operating hours.

5.2. Maintenance work every 8 – 15 operating hours

5.2.1. Check engine oil level

When the oil level is checked, the engine must be stopped and in a horizontal position.

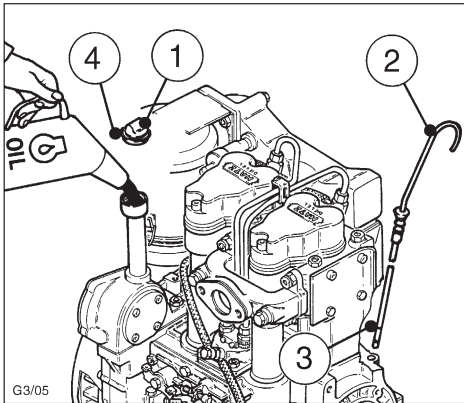

15

- Check the oil level at dipstick „2“, add oil if necessary until the level reaches upper mark „3“ (chap. 4.1.1.).

5.2.2. Check combustion air intake area

Heavy contamination is an indication that increased dust accumulation necessitates a correspondingly shorter maintenance interval, Chapter 5.3.1. and 5.4.2.

With oilbath air cleaner:

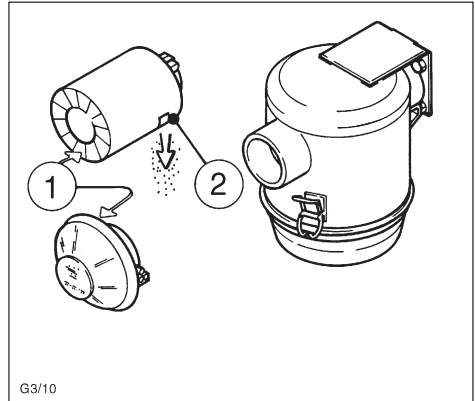

16

- Inspect air inlets „1“ (depending on version) for severe dirt and dust deposits, and clean if necessary.
- Make sure that dust outlet „2“ on the cyclone-type dust trap (depending on version) is not obstructed, and clean if necessary (chap. 5.3.1.).

With dry-type air cleaner:

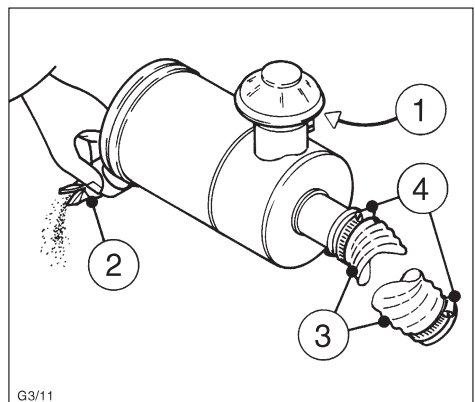

17

- Inspect air inlets „1“ and clean if necessary.
- Check that dust discharge valve „2“ is not obstructed; eliminate dust blockage by pressing together as shown.

- Check that connecting hose „3“ and hose clips „4“ are in good condition and not leaking (fig. 17).

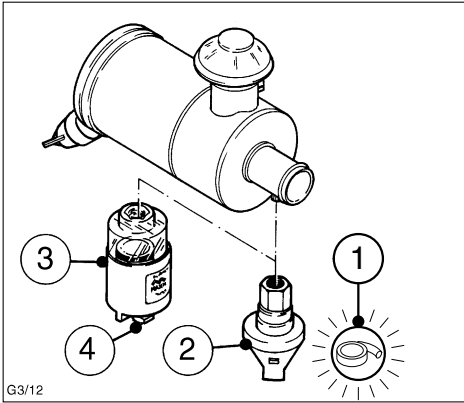

G3/12

18

- Run the engine up to maximum speed briefly and check that indicator lamp „1“ (depending on version) comes on briefly or that the red zone is visible in maintenance indicator „3“.

5.2.3. Check the cooling air system

Heavy contamination is an indication that increased dust accumulation necessitates a correspondingly shorter maintenance interval.

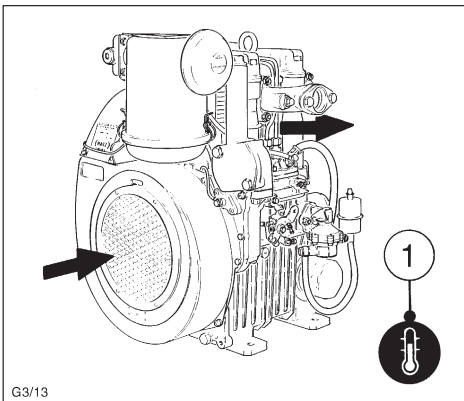

G3/13

19

- Inspect air inlets and outlets for coarse soiling such as leaves, dust accumulation etc., clean if necessary (fig. 19, chap. 5.3.4.).

The temperature indicator „1“ – if installed – will light up as soon as the engine becomes too hot.

Shut down the engine immediately!

5.3. Maintenance work every 250 operating hours

5.3.1. Maintenance work on oilbath air cleaner

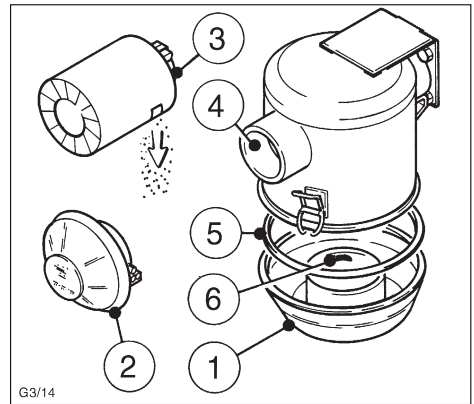

G3/14

20

- Take off oil tank „1“ and clean it.
- Take off rain cap „2“ or cyclone-type dust trap „3“, and clean.
- Clean right through intake pipe „4“
- Check condition of sealing ring „5“ and renew if necessary.
- Add engine oil to the oil tank up to mark „6“ and re-assemble the oilbath air cleaner (fig. 20, chap. 4.1.2.).

If the filter packing is severely contaminated with dust and dirt, the upper part of the air cleaner must also be cleaned as follows:

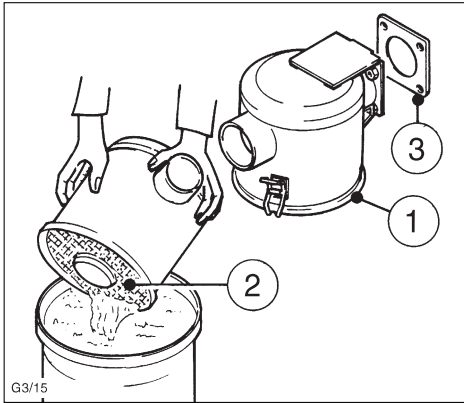

21

- Detach upper part of air cleaner „1“ from engine and rinse in diesel fuel.
- Allow the diesel fuel drip off thoroughly, or wipe it off, before re-assembling.
- Install a new filter packing if the sealing surface is uneven, the body of the filter is cracked and/or filter wool is missing.
- Install the upper part of the air cleaner, using a new flange gasket „3“.
- Re-assemble the remaining parts of the air cleaner and fill with oil to prepare for further operation (chap. 4.1.2.).

5.3.2. Engine oil change and oil filter renewal

The engine must be stopped and in a horizontal position.

Drain the engine oil only when the engine is warm.



Danger of scalding from hot oil!
Trap the old oil and dispose of it in accordance with local legislation.

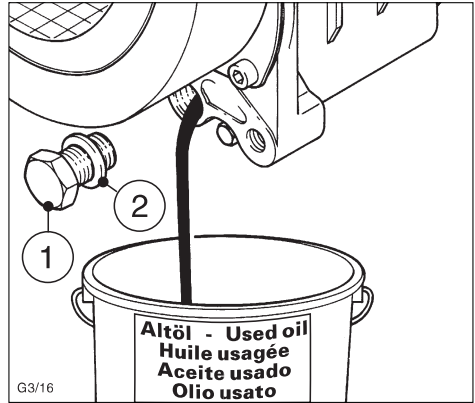

22

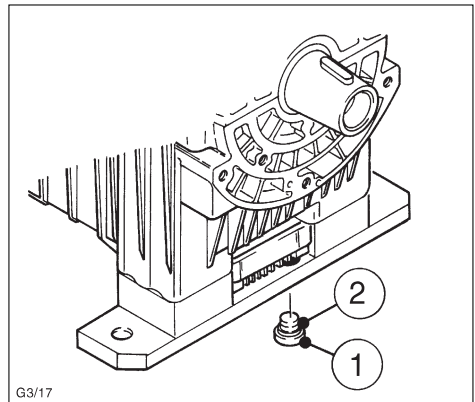

23

- Take out drain plug „1“ and allow the oil to drain out completely (fig. 22 without oil sump, fig. 23 with oil sump).
- Insert oil drain plug „1“ with a **new** sealing ring „2“ and tighten.

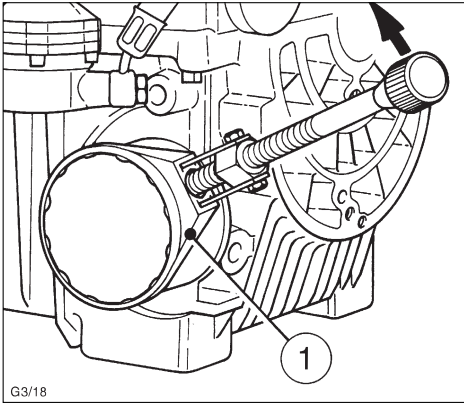

24

- Slacken off and unscrew the throwaway engine oil filter using HATZ strap wrench „1“, Order No. 620 307 01, or a similar tool.

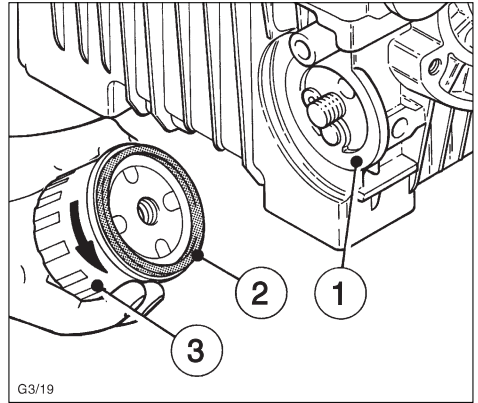

26

- Clean sealing face „1“ thoroughly.
- Oil sealing ring „2“ on the new filter element lightly.
- Screw in throwaway filter element „3“ **handtight**.
- Add engine oil (chap. 4.1.1.).
- Run the engine briefly to check that there are no leaks at the oil filter; take up slack if necessary.

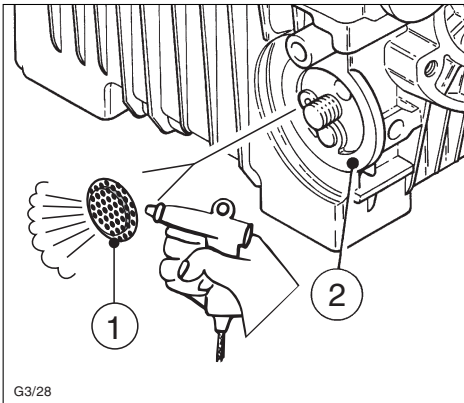

25

- Use a screwdriver to lift mesh screen „1“, which is located behind the filter element, away from the oil pressure relief valve. Do not damage contact face „2“.
- Clean mesh screen „1“ from the inside by blowing through with compressed air.
- After cleaning, press the mesh screen back on to the oil pressure relief valve.

Never re-use the throwaway filter element.

Check the oil level; add oil if necessary.

5.3.3. Check and adjust valve clearances

- Adjust only when the engine is cold (10 - 30 °C).
- Remove any dirt from the area where the cover is attached to the cylinder head.

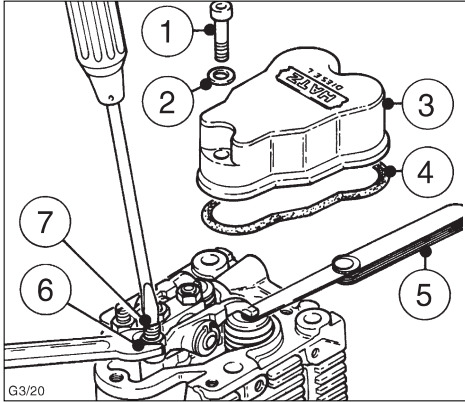

27

- Remove screws „1“ and take off cover „3“ complete with sealing rings „2“ and „4“. Never re-use these sealing rings.

Adjusting procedure:

- Cylinder 1 is at the flywheel end; clockwise rotation.
Cylinder 2 is at the power take-off end; anti-clockwise rotation.
- Turn the engine in its normal direction of rotation until the valves in cylinder 2 are in the overlap position (exhaust valve not yet closed, inlet valve starts to open).
- Turn the crankshaft through 180 degrees in the normal direction of rotation, then check valve clearances for cylinder 1 and adjust if necessary.
- Turn the crankshaft through a further 180 degrees; check valve clearances for cylinder 2 and adjust if necessary.

Adjusting:

- Measure valve clearance with 0.10 mm feeler gauge „5“ (fig. 27, chapt. 3.1.).
- If adjustment is necessary, slacken off hex nut „6“, turn adjusting screw „7“ and retighten nut „6“. It should then be possible to pull feeler gauge „5“ through with just perceptible resistance to movement (fig. 27).
- Replace the cover in position and tighten it down uniformly.
- Run the engine briefly to check that there are no leaks at the cover.

5.3.4. Clean the cooling air system

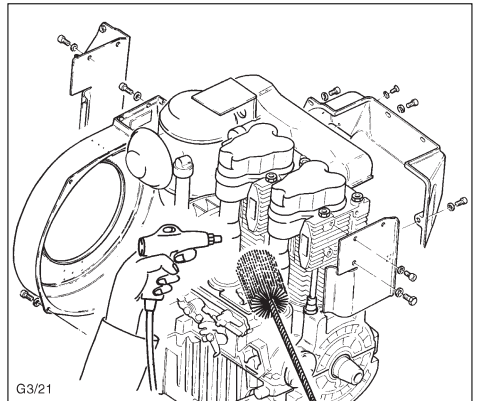

28

- Take off all air guides.

If dirt deposits are dry:

- Clean all air guides and the entire cooling air system including cylinder heads, cylinders and flywheel blades without making them wet, and blow them through with compressed air.

If dirt deposits are damp or oily:

- Disconnect the battery.
- Apply a detergent solution (cold cleaner or similar) to the entire system in accordance with the manufacturer's instructions, then spray off with a powerful water jet.

Do not spray water directly on to electrical equipment or plug connections; if this does occur, dry them immediately with compressed air.

- Establish the cause of contamination with oil and have any leaks repaired.

Re-attach all air guides.



The engine must never be run without the air guides.

- Run the engine immediately after re-assembly until it is warm; this will prevent rust from forming.

5.3.5. Check threaded connections

Check the condition and tightness of all threaded connections, pipes and lines, hose clips and other fastenings on the engine or its mountings which can be reached during maintenance work.

Do not tighten the cylinder head bolts.

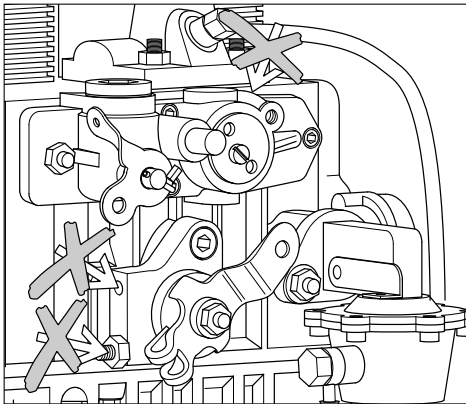

29



The adjusting screws at the engine governor and on the injection system are sealed with lacquer or with lead and are not to be tightened or adjusted.

5.4. Maintenance work every 500 hours of operation

5.4.1. Renew the fuel filter

The maintenance intervals for the fuel filter are dependent upon the purity of the diesel oil being used and, if necessary, may have to be reduced to 250 hours.



When working on the fuel system, do not expose it to naked flames; do not smoke.

Important!

Keep the entire area clean so that no dirt reaches the fuel.

- Shut off the fuel supply.

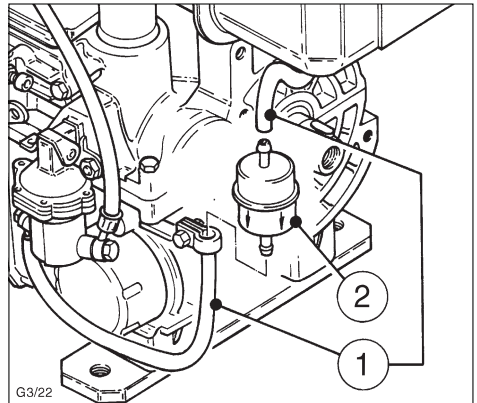

30

- Pull fuel feed line „1“ off fuel filter „2“ at both sides, and insert a new filter. Make sure that the direction of fuel flow is as shown by the arrows.
- Open up the fuel supply again and if necessary operate the priming pump (chap. 4.1.3.).
- Run the engine briefly to check that there are no leaks at the fuel filter and fuel lines.

5.4.2. Dry-type air cleaner maintenance

It is best to clean the filter cartridge only when the maintenance indicator displays the appropriate signal. This is only the case if the maintenance indicator functions properly (chap. 6.1.). Apart from this, the cartridge should be renewed after 500 hours of operation.

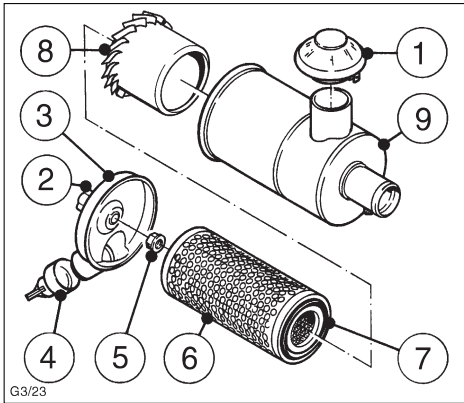

31

- Take off rain cap „1“ and clean it.
- Slacken off wingnut „2“ and remove cover „3“ with dust discharge valve „4“.
- Examine the cover and dust discharge valve for distortion, aging and cracks; renew if necessary.
- Unscrew and remove collar nut „5“.
- Carefully pull out filter element „6“.
- The cartridge may no longer be used if there is damage to the filter „6“ or in the area of the lip seal „7“.
- Pull guide „8“ out of filter housing „9“.
- Clean all parts except the filter element.

Do not spray into the engine air intake.

Cleaning the filter cartridge

Dry contamination

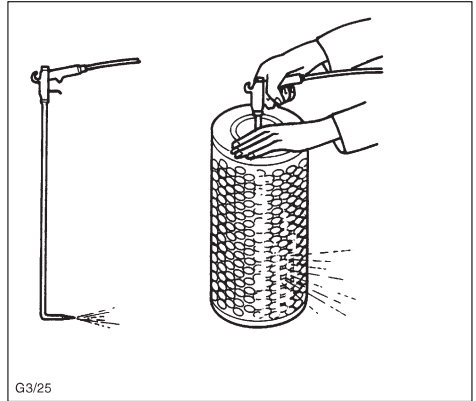

32

- Using a compressed-air pistol with a bent tube insert, blow through the cartridge from the inside with dry compressed air, moving up and down, until no more dust is emitted.

Important!

The pressure must not exceed max. 5 bar.

Wet or oily contamination

Replace the filter cartridge.

- Assembly is carried out in reverse order.

Check the seal insert of collar nut „5“, replace the collar nut if the seal insert is missing. Ensure that the dust extractor valve is correctly positioned downwards (fig. 31).

- When the filter has been installed, unlock maintenance indicator „3“ – if installed – by pressing reset button „4“ (fig. 33).

6. Functional test

6.1. Air filter maintenance indicators

(only on version with Dry-type air cleaner)

For electrical indicator

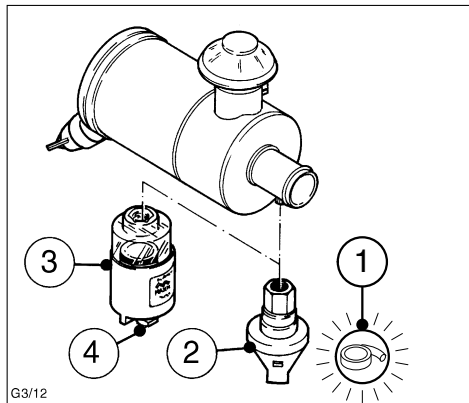

G3/12

33

- Unscrew maintenance switch „2“ then reconnect to the on-board electric system.

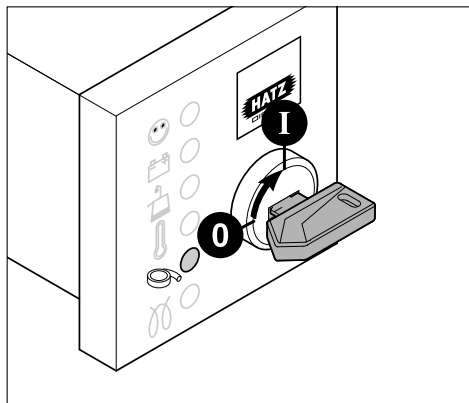

34

- Turn the ignition key to **position I**.

- Create a vacuum at the maintenance switch with powerful suction, indicator lamp „1“ must light up (fig. 33).
- If there is no reaction, check cable connectors and replace filament lamp and/or maintenance switch if necessary.

For mechanical indicator

- Unscrew maintenance indicator „3“ (fig. 33).
- Create a vacuum at the maintenance indicator with powerful suction, the visible red area must latch in, replace maintenance indicator if necessary.
- Before putting into operation, unlock maintenance indicator „3“ with reset button „4“

7. Malfunctions – causes and remedies

Malfunctions	Possible causes	Remedy	Chap.
The engine does not start or not immediately, can however be turned over with the starter motor.	Speed adjustment lever in the stop or idle position. Stop lever in stop position.	Move the lever in START position.	4.2.1.
	No fuel at the fuel-injection pump.	Fill up with fuel. Check the complete fuel supply system systematically. If no result, check: - fuel supply line to the engine. - fuel filter. - function of the feed pump.	4.1.3. 5.4.1. 4.1.3.
	Insufficient compression: - Wrong valve clearances	Check valve clearances, adjust if necessary.	5.3.3.
	- Valves worn out. - Worn out cylinders and/or piston rings.	See workshop manual.	
	Unserviceable injector jets.	See workshop manual.	
At low temperatures.	Below the start-limit temperatures.	Operate glow-plug equipment (additional equipment).	4.2.2.
	Device not disengaged.	Disengage the engine from the device - if possible.	
	Glow-plug equipment defective (additional equipment).	See workshop manual.	
	Fuel flocculent due to inadequate cold stability.	Pull out the return line and check whether clear, uncloudy fuel comes out when operating the feed pump. If the fuel is flocculent, either warm up the engine or drain off the complete fuel supply system. Refill with temperature-resistant fuel mixture.	4.1.3. 4.1.3.

Malfunctions	Possible causes	Remedy	Chap.
At low temperatures.	Starting speed too low: - Oil too viscous.	Replace and fill up with oil.	5.3.2. 4.1.1.
	- Battery inadequately charged.	Check the battery, if necessary contact a service station.	8.
Starter motor does not operate or engine does not turn over.	Discrepancies in the electrical system: - Battery and/or other cable connections wrongly connected. - Loose and/or oxidized cable connections. - Battery defective and/or not charged. - Starter motor defective. - Defective relays, monitoring elements etc.	Check the electrical system and its components or contact HATZ service station !	8.
	Engine ignites, but stops running as soon as the starter motor is disengaged.	Speed control lever not located far enough in the start direction. Device not disengaged. Fuel filter blocked. Fuel supply interrupted.	Move the lever to START position. Disengage the engine from the device if possible. Replace fuel filter. Check the entire fuel supply systematically.
Engine shuts down independently during operation.	Fuel supply interrupted: - Tank run dry - Fuel filter blocked. - Fuel feed pump defective.	Fill up with fuel. Replace fuel filter. Check the entire fuel supply system.	4.1.3. 5.4.1. 4.1.3.
	Mechanical malfunctions.	Contact a HATZ service station.	

Malfunctions	Possible causes	Remedy	Chap.
Drop off in performance and speed of the engine.	Fuel supply detrimentally affected:		
	- Tank run dry.	Fill up with fuel.	4.1.3.
	- Fuel filter blocked.	Replace fuel filter.	5.4.1.
	- Inadequate tank ventilation.	Ensure adequate ventilation of the tank.	
	- Line connections leaky.	Check the line screw-connections for leaks.	
	- The speed control lever does not remain in the required position.	Block the speed control.	
Drop off in engine performance and speed, black smoke from the exhaust.	Air filter contaminated.	Clean air filter.	5.3.1.
	Incorrect valve clearances.	Adjust valve clearances.	5.4.2.
	Injector jets unserviceable.	See workshop manual.	5.3.3.
Engine runs very hot, the indicator lamp for cylinder head temperature (additional equipment) comes on.	Too much oil in the engine.	Drain off oil to the upper mark on the dipstick.	5.3.2.
	Inadequate cooling:		
	- Contamination in the entire area for the air guides.	Clean the area of cooling air.	5.3.4.
	- Insufficiently enclosed air guides.	Check that the air guides and shafts are complete and that they are sealed.	

8. Work on the electrical system



Batteries generate explosive gases. Keep them away from naked flame and sparks which could cause them to ignite.

Do not smoke.

Protect eyes, skin and cloth against the corrosive battery acid. Pour clear water over acid splashes immediately. In case of emergency call doctor.

Do not place any tools on top of the battery.

- The **positive (+)** and **negative (-)** battery terminals must not be accidentally interchanged.
- When **installing the battery**, connect the **positive lead** first, followed by the **negative lead**. Negative pole to earth (ground) on engine block.
- When **removing the battery**, disconnect the **negative lead** first, followed by the **positive lead**.
- In all circumstances, **avoid short circuits** and shorts to earth (ground) at life cables.
- If electrical faults occur, first **check** for good contact at the **cable connections**.
- If bulbs blow in the telltale, warning and indicator lights, **renew** them immediately.
- Do not take the key out while the engine is running.
- Never **disconnect the battery** while the engine is running. Electric voltage peaks can cause damage to electrical components.
- When cleaning the engine, do not spray electrical components with water. If this is unavoidable, first disconnect the battery. Dry all components carefully with compressed air before reconnecting them.

- When carrying out **welding work** on the engine or attached equipment, attach the earth (ground) clip as near as possible to the welding point, and disconnect the battery. If an alternator is fitted, separate the plug connector leading to the voltage regulator.

The relevant circuit diagrams are supplied with engines which have an electrical system. Additional copies of circuit diagrams can be obtained on request.

HATZ assumes no liability for electrical systems which was not carried out acc. HATZ circuit diagrams.

9. Protective treatment

A new engine can normally be stored for up to 12 months in a dry place. If atmospheric humidity is high (or if exposed to sea air), protection is sufficient for about 6 months' storage. If the engine is to be stored for a longer period, or laid up out of use, please consult the nearest HATZ service point.

**SUPPLEMENTAL INFORMATION
TO THE OWNER'S MANUAL FOR 2008 AND LATER
EPA CERTIFIED
NONROAD COMPRESSION IGNITION ENGINES.**

**EPA EMISSION CONTROL SUPPLEMENTAL
WARRANTY STATEMENT AND
EMISSION-RELATED INSTALLATION
INSTRUCTIONS.**

MAINTENANCE AND WARRANTY.

SUPPLEMENTAL INFORMATION TO THE OWNERS MANUAL FOR 2008 AND LATER EPA CERTIFIED NONROAD COMPRESSION IGNITION ENGINES.

The following supplemental information is furnished for EPA Nonroad Compression Ignition Engines which are certified according to 40 CFR Part 89 and Part 1039.

This information contains the following specific items:

- EPA-related engine parts and engine operating conditions
- Maintenance instructions for EPA-related engine parts
- Emission control system and adjustments
- Warranty statement
- Emission-related installation instructions

ENGINE PARTS AND / OR EQUIPMENT RELATED TO EPA EXHAUST EMISSION REGULATIONS.

Parts which are mandatory for engine operation.

The following parts as manufactured according to HATZ specifications are mandatory for engine operation which meets EPA exhaust emission regulations.

- Fuel injection pump
- Injection nozzle(s)
- Extra fuel device
- Crankcase breather valve assembly
- Air cleaner housing
- Intake manifold

- Exhaust manifold
- Oil filler cap
- Intake and exhaust gaskets at head interfaces
- Emission Control Information Labels

Only parts manufactured by Hatz and which have passed the Hatz Quality Assurance Program are assured of meeting EPA exhaust emission regulations.

UNUSUAL OPERATING CONDITIONS.

The engine must not be operated at a load factor less than 25 % for an extended period as such operation will cause the fuel injector to foul. If such a condition occurs, you should contact the nearest HATZ authorized Service Center for necessary repairs.

The engine is designed and adjusted to operate most efficiently at the following conditions:

- Air temperature of 25° C (77° F)
- Atmospheric pressure of 100 kPa (14.5 psi)
- Relative humidity of 30 %

Operation of the engine at conditions other than above will affect performance and exhaust emissions. Normally the equipment manufacturer takes this into account during the design of the machine and your equipment will perform within specifications over a wide range of climatic conditions. However if you must operate your equipment under very unusual climatic conditions, please contact your nearest Hatz distributor for advice.

MAINTENANCE SCHEDULE-EPA-RELATED PARTS

The following minimum intervals are being adopted for adjustment, cleaning, repair, or replacement of following components:

At 1,500 hours, and 1,500-hours intervals thereafter:

- Fuel injector tips (cleaning only)

At 3,000 hours, and 3,000-hours intervals thereafter:

- Fuel injector

The exhaust quality of the engines can be influenced by the execution (the quality of execution) of above described maintenance work.

Therefore, the maintenance work has to be carried out by a qualified workshop. Hatz authorised workshops, for example, are qualified workshops.

Hatz Diesel of America will give you respective addresses, if required.

EMISSION CONTROL SYSTEM AND ADJUSTMENTS.

The emission control system for this engine is EM (Engine Modification). No adjustments are needed or possible.

EPA EMISSION CONTROL WARRANTY STATEMENT

YOUR WARRANTY RIGHTS AND OBLIGATIONS.

Motorenfabrik Hatz GmbH & Co. KG warrants the emission control system on your engine for the periods of time listed below provided there has been no abuse, neglect or improper maintenance of your engine.

Your emission control system includes:

- Fuel injection pump
- Injection nozzle(s)
- Extra fuel device
- Crankcase breather valve assembly
- Air cleaner housing
- Intake manifold
- Exhaust manifold
- Oil filler cap
- Intake and exhaust gaskets at head interfaces
- Emission Control Information Labels

Where a warrantable condition exists, Motorenfabrik Hatz will repair your engine at no cost to you including diagnosis, parts and labor.

MANUFACTURERS WARRANTY COVERAGE:

The 2008 and later EPA certified nonroad compression ignition engines are warranted for 1500 hours of operation or two years of use, whichever first occurs.

If any emission related part on your engine is defective, the part will be repaired or replaced by Motorenfabrik Hatz.

OWNERS WARRANTY RESPONSIBILITIES:

- As the engine owner, you are responsible for the performance of the required maintenance listed in your owner's manual. Motorenfabrik Hatz recommends that you retain all receipts covering maintenance on your engine, but Motorenfabrik Hatz cannot deny warranty solely for the lack of receipts or for your failure to ensure the performance of all scheduled maintenance.
- As the engine owner, you should be aware, however, that Motorenfabrik Hatz may deny you warranty coverage if your engine or a part has failed due to abuse, neglect, improper maintenance or unapproved modifications.
- You are responsible for presenting your engine to a Motorenfabrik Hatz authorized service center as soon as a problem exists. The warranty repairs should be completed in a reasonable amount of time, not to exceed 30 days.

If you have any questions regarding your warranty rights and responsibilities, you should contact HATZ DIESEL OF AMERICA, Inc. at (262) 544-0254.

HATZ DIESEL SUPPLEMENTAL WARRANTY FOR 2008 AND LATER EPA CERTIFIED ENGINES.

PARTS WITH SUPPLEMENTAL LIMITED WARRANTY.

The following limited warranty is supplemental to the standard HATZ DIESEL LIMITED ENGINE WARRANTY and covers 2008 and later EPA certified engines and applies to the following exhaust emission-related components:

- Fuel injection pump
- Injection nozzle(s)
- Extra fuel device
- Crankcase breather valve assembly
- Air cleaner housing
- Intake manifold
- Exhaust manifold
- Oil filler cap
- Intake and exhaust gaskets at head interfaces
- Emission Control Information Labels

SUPPLEMENTAL LIMITED WARRANTY.

Hatz Diesel of America, Inc. hereinafter referred to as “HATZ” warrants each of the above-listed parts when installed in a new engine sold by Hatz to be free from defects in material and workmanship under normal use and service, only under the named warranty coverage conditions, after the date of delivery to the original retail purchaser and Hatz will at their option, repair or replace at Hatz's sales headquarters, or at a point designated by Hatz, any part or parts which shall appear to the satisfaction of Hatz upon inspection at such point, to have been defective in material or workmanship.

- Any warranted part which is scheduled for replacement as required maintenance is warranted for the period of time up to the first scheduled replacement point for that part.
- Any replacement part which is equivalent in performance and durability may be used in non-warranty maintenance or repairs and will not reduce the overall engine warranty obligations of Hatz. However, Hatz is not responsible for failure of such replacement parts or failure of any other parts directly caused by failure of such replacement parts.
- This warranty does not obligate Hatz to bear any transportation charges in connection with the repair or replacement of defective parts. This warranty is transferrable to subsequent owners, only under the named warranty coverage conditions.
- In order to obtain service under this warranty, the retail purchaser should contact Hatz Diesel of America, Inc. at (262) 544-0254 for information and the nearest service center. The retail purchaser will not be charged for diagnostic labor which leads to the determination that a warranted part is defective, nor for the repair or replacement of warranted parts if the work is performed at an authorized Hatz service center. If other engine components are damaged due to a failure of the above-listed warranted parts still under warranty, these other engine components will also be repaired or replaced at no charge.
- This warranty shall not apply to any engine which shall have been installed or operated in a manner not recommended by Hatz, nor to any engine which shall have been repaired, altered, neglected, or used in any way which, in the opinion of Hatz, adversely affects its performance, nor to any engine in which parts not authorized by Hatz have been used, which parts or the use of which have damaged or caused defects in or otherwise adversely affected the engine or its performance, nor to normal maintenance service or replacement of normal service items.

Hatz reserves the right to modify, alter, and improve any engine or parts without incurring any obligation to replace any engine or parts previously sold with such modified, altered, or improved engine or parts

EMISSION-RELATED INSTALLATION INSTRUCTIONS

“Failing to follow these instructions when installing a certified engine in a piece of nonroad equipment violates federal law (40CFR1068.105(b)), subject to fines or other penalties as described in the Clean Air Act.”

“If you install the engine in a way that makes the engine's emission control information labels hard to read during normal engine maintenance, you must place duplicate labels on the equipment.”

EQUIPMENT-LABELLING REQUIREMENTS: FUEL LABEL (Chapter 3.5)

The fuel label has to be permanently attached to the equipment.

In case of an engine mounted fuel tank, every engine is equipped with an additional fuel label.

Otherwise, there are two loose fuel labels available with the engine.

If the original fuel label is not readily visible after the engine is installed in the equipment then the second loose fuel label must be attached on the equipment in such a manner that it is readily visible to an average person.

INSTRUCTIONS ON THE INSTALLATION OF THE EXHAUST SYSTEM

Following are the instructions to properly install the exhaust system and related components consistent with the EPA emission regulation requirements.

2 G 40

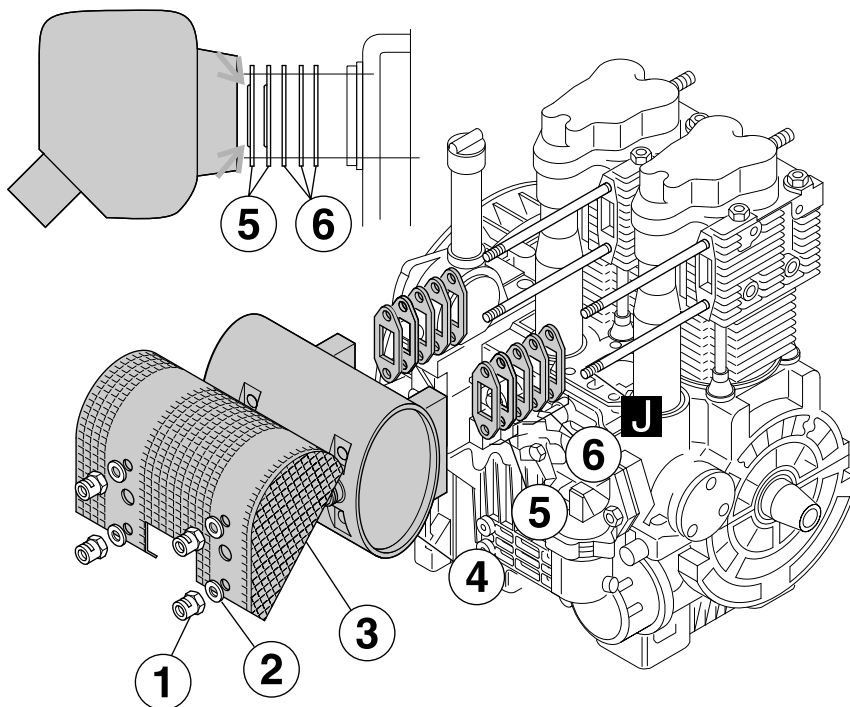

Exhaust-silencers and protection guard

The exhaust silencer is fitted in connection with studs, flat washers and hex.-nuts. Fixation is done by Allen screws.

Dismantling:

- Remove protection guard **3** in numerical sequence **1...3** if so fitted. It is mounted to the exhaust silencer with four screws.
- Remove silencer **4** and gaskets **5** and **6**.

Assembly:

- Assemble in reverse sequence.
- Apply lubricant as specified by HATZ.
- Ensure gasket-kit is fitted in correct sequence i.e. the creased gaskets **5** face towards exhaust silencer.
- Assemble protection guard if so fitted in reverse sequence **3...1**.
- Use anti-seize compound **J** as specified by HATZ.

SAMPLING OF EXHAUST EMISSIONS

After the engine is installed in the equipment and placed in service, the sampling of exhaust emissions can be performed in a way that prevents diluting the exhaust sample with ambient air as follows:

Version 1

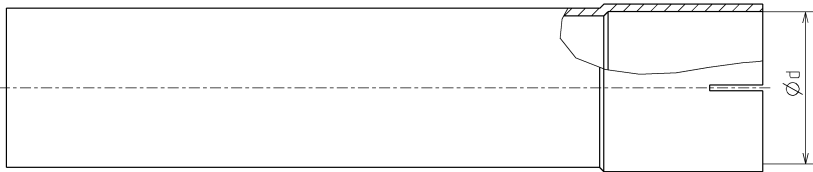

Specification 1: Adding a 20-centimeter linear extension to the exhaust pipe

Version 2

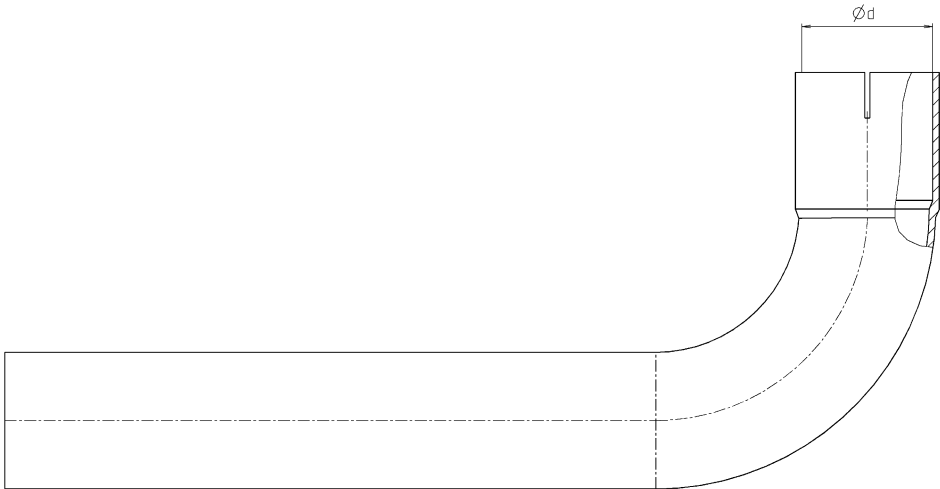

Specification 2: Adding a 20-centimeter bended extension to the exhaust pipe

Engine type	$\varnothing d$ (mm)	Version 1 HATZ-Ident. Nr.	Version 2 HATZ-Ident. Nr.	Clamp HATZ-Ident. Nr.
2G40 (H)	40	830 582 00	830 853 00	503 398 00

**SUPPLEMENTAL INFORMATION
TO THE OWNER'S MANUAL
FOR 2008 AND LATER
CALIFORNIA REGULATIONS FOR
HEAVY-DUTY OFF-ROAD ENGINES**

**CALIFORNIA EMISSION CONTROL
WARRANTY STATEMENT AND
EMISSION-RELATED INSTALLATION
INSTRUCTIONS.**

MAINTENANCE AND WARRANTY.

SUPPLEMENTAL INFORMATION TO THE OWNER'S MANUAL FOR 2008 AND LATER CALIFORNIA REGULATIONS FOR HEAVY-DUTY OFF-ROAD ENGINES.

The following supplemental information is furnished for California Heavy-Duty Off-Road Engines.

This information contains the following specific items:

- CARB-related engine parts and engine operating conditions
- Maintenance instructions for CARB-related engine parts
- Emission control system and adjustments
- Warranty statement
- Emission-related installation instructions

ENGINE PARTS AND / OR EQUIPMENT RELATED TO CARB EXHAUST EMISSION REGULATIONS.

Parts which are mandatory for engine operation.

The following parts as manufactured according to HATZ specifications are mandatory for engine operation which meets CARB exhaust emission regulations.

- Fuel injector(s)
- Fuel injection pump
- Cold start device
- Intake manifold
- Exhaust manifold
- Crankcase breather valve
- Oil filler Cap

- Intake and exhaust gaskets at head interfaces
- Emission Control Information Labels

Only parts manufactured by Hatz and which have passed the Hatz Quality Assurance Program are assured of meeting CARB exhaust emission regulations.

UNUSUAL OPERATING CONDITIONS.

The engine must not be operated at a load factor less than 25 % for an extended period as such operation will cause the fuel injector to foul. If such a condition occurs, you should contact the nearest HATZ authorized Service Center for necessary repairs.

The engine is designed and adjusted to operate most efficiently at the following conditions:

- Air temperature of 25° C (77° F)
- Atmospheric pressure of 100 kPa (14.5 psi)
- Relative humidity of 30 %

Operation of the engine at conditions other than above will affect performance and exhaust emissions. Normally the equipment manufacturer takes this into account during the design of the machine and your equipment will perform within specifications over a wide range of climatic conditions. However if you must operate your equipment under very unusual climatic conditions, please contact your nearest Hatz distributor for advice.

MAINTENANCE SCHEDULE-CARB-RELATED PARTS.

The following minimum intervals are being adopted for adjustment, cleaning, repair, or replacement of following components:

At 1,500 hours, and 1,500 hours intervals thereafter:

- Fuel injector tips (cleaning only)

At 3,000 hours, and 3000 hours intervals thereafter:

- Fuel Injectors

The exhaust quality of engines can be influenced by the execution (the quality of execution) of above described maintenance work.

Therefore, the maintenance work has to be carried out by a qualified workshop. Hatz authorised workshops, for example, are qualified workshops. Hatz Diesel of America will give you respective addresses, if required

EMISSION CONTROL SYSTEM AND ADJUSTMENTS.

The emission control system for this engine is EM (Engine Modification). No adjustments are needed or possible.

CALIFORNIA EMISSION CONTROL SYSTEM WARRANTY STATEMENT. YOUR WARRANTY RIGHTS AND OBLIGATIONS.

The **California Air Resources Board** and Motorenfabrik Hatz GmbH & Co. KG are pleased to explain the **emission control system warranty** on your **2008 and later** engine. In California, new heavy-duty off-road engines must be designed, built, and equipped to meet the State's stringent anti-smog standards. The Motorenfabrik Hatz GmbH & Co. KG must warrant the emission control system on your engine for the periods of time listed below provided there has been no abuse, neglect or improper maintenance of your engine.

Your emission control system may include parts such as the fuel-injection system and the air induction system. Also included may be hoses, belts, connectors and other emission-related assemblies.

Where a warrantable condition exists, the Motorenfabrik Hatz GmbH & Co. KG will repair your heavy-duty off-road engine at no cost to you including diagnosis, parts, and labor.

MANUFACTURER'S WARRANTY COVERAGE.

The 2008 and later heavy-duty off-road engines are warranted for **1500 hours of operation or two years of use, whichever first occurs.**

If any emission-related part on your engine is defective, the part will be repaired or replaced by Motorenfabrik Hatz GmbH & Co. KG.

OWNER'S WARRANTY RESPONSIBILITIES.

- As the heavy-duty off-road engine owner, you are responsible for the performance of the **required maintenance listed in your owner's manual.**
Motorenfabrik Hatz GmbH & Co. KG recommends that you retain all receipts covering maintenance on your heavy-duty off-road engine, but Motorenfabrik Hatz GmbH & Co. KG cannot deny warranty solely for the lack of receipts or for your failure to ensure the performance of all scheduled maintenance.
- As the heavy-duty off-road engine owner, you should however be aware that Motorenfabrik Hatz GmbH & Co. KG may deny you warranty coverage if your heavy-duty off-road engine or a part has failed due to abuse, neglect, improper maintenance or unapproved modifications.
- Your engine is designed to operate on low sulfur diesel fuel or ultra-low sulfur diesel fuel only. Use of any other fuel may result in your engine no longer operating in compliance with California's emissions requirements.
- You are responsible for initiating the warranty process. The ARB suggests that you present your heavy-duty off-road engine to a Motorenfabrik Hatz authorised dealer as soon as a problem exists. The warranty repairs should be completed by the dealer as expeditiously as possible.

If you have any questions regarding your warranty rights and responsibilities, you should contact Hatz Diesel of America, Inc. at **(262)-544-0254.**

HATZ DIESEL SUPPLEMENTAL WARRANTY FOR 2008 AND LATER CALIFORNIA CERTIFIED HEAVY-DUTY OFF-ROAD ENGINES.

PARTS WITH SUPPLEMENTAL LIMITED WARRANTY.

The following limited warranty is supplemental to the standard HATZ DIESEL LIMITED ENGINE WARRANTY and covers 2008 and later California certified Heavy-Duty off-road engines and applies to the following exhaust emission-related components:

- Fuel injector(s)
- Fuel injection pump
- Cold start device
- Intake manifold
- Exhaust manifold
- Crankcase breather valve
- Oil filler cap
- Intake and exhaust gaskets at head interfaces
- Emission Control Information Labels

SUPPLEMENTAL LIMITED WARRANTY.

Hatz Diesel of America, Inc. hereinafter referred to as „HATZ“ warrants each of the above-listed parts when installed in a new engine sold by Hatz to be free from defects in material and workmanship under normal use and service, for a period of twenty-four (24) months after the date of delivery to the original retail purchaser and Hatz will at their option, repair or replace at Hatz’s sales headquarters, or at a point designated by Hatz, any part or parts which shall appear to the satisfaction of Hatz upon inspection at such point, to have been defective in material or workmanship.

- Any warranted part which is scheduled for replacement as required maintenance is warranted for the period of time up to the first scheduled replacement point for that part.
- Any replacement part which is equivalent in performance and durability may be used in non-warranty maintenance or repairs and will not reduce the overall engine warranty obligations of Hatz. However, Hatz is not responsible for failure of such replacement parts or failure of any other parts directly caused by failure of such replacement parts.
- This warranty does not obligate Hatz to bear any transportation charges in connection with the repair or replacement of defective parts. This warranty is transferrable to subsequent owners within the original twenty-four (24) months time period.
- In order to obtain service under this warranty, the retail purchaser should contact Hatz Diesel of America, Inc. at (262) 544-0254 for information and the nearest service center. The retail purchaser will not be charged for diagnostic labor which leads to the determination that a warranted part is defective, nor for the repair or replacement of warranted parts if the work is performed at an authorized Hatz service center. If other engine components are damaged due to a failure of the above-listed warranted parts still under warranty, these other engine components will also be repaired or replaced at no charge.
- This warranty shall not apply to any engine which shall have been installed or operated in a manner not recommended by Hatz, nor to any engine which shall have been repaired, altered, neglected, or used in any way which, in the opinion of Hatz, adversely affects its performance, nor to any engine in which parts not authorized by Hatz have been used, which parts or the use of which have damaged or caused defects in or otherwise adversely affected the engine or its performance, nor to normal maintenance service or replacement of normal service items.

Hatz reserves the right to modify, alter, and improve any engine or parts without incurring any obligation to replace any engine or parts previously sold with such modified, altered, or improved engine or parts.

EMISSION-RELATED INSTALLATION INSTRUCTIONS

“Failing to follow these instructions when installing a certified engine in a piece of nonroad equipment violates federal law (40CFR1068.105(b)), subject to fines or other penalties as described in the Clean Air Act.”

“If you install the engine in a way that makes the engine's emission control information labels hard to read during normal engine maintenance, you must place duplicate labels on the equipment.”

EQUIPMENT-LABELLING REQUIREMENTS: FUEL LABEL (Chapter 3.5)

The fuel label has to be permanently attached to the equipment.

In case of an engine mounted fuel tank, every engine is equipped with an additional fuel label.

Otherwise, there are two loose fuel labels available with the engine.

If the original fuel label is not readily visible after the engine is installed in the equipment then the second loose fuel label must be attached on the equipment in such a manner that it is readily visible to an average person.

INSTRUCTIONS ON THE INSTALLATION OF THE EXHAUST SYSTEM

Following are the instructions to properly install the exhaust system and related components consistent with the EPA emission regulation requirements.

2 G 40

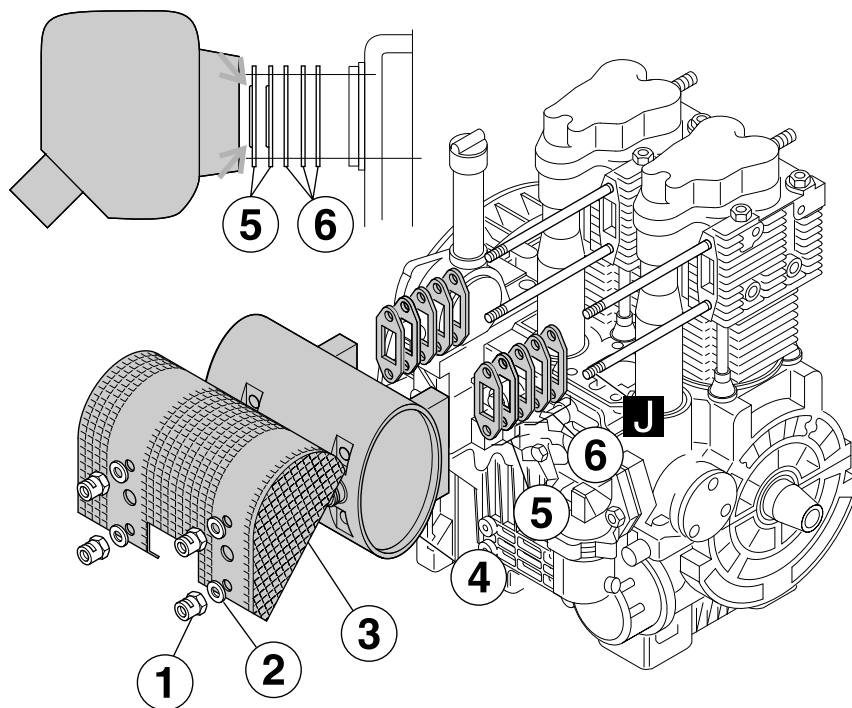

Exhaust-silencers and protection guard

The exhaust silencer is fitted in connection with studs, flat washers and hex.-nuts. Fixation is done by Allen screws.

Dismantling:

- Remove protection guard **3** in numerical sequence **1...3** if so fitted. It is mounted to the exhaust silencer with four screws.
- Remove silencer **4** and gaskets **5** and **6**.

Assembly:

- Assemble in reverse sequence.
- Apply lubricant as specified by HATZ.
- Ensure gasket-kit is fitted in correct sequence i.e. the creased gaskets **5** face towards exhaust silencer.
- Assemble protection guard if so fitted in reverse sequence **3...1**.
- Use anti-seize compound **J** as specified by HATZ.

SAMPLING OF EXHAUST EMISSIONS

After the engine is installed in the equipment and placed in service, the sampling of exhaust emissions can be performed in a way that prevents diluting the exhaust sample with ambient air as follows:

Version 1

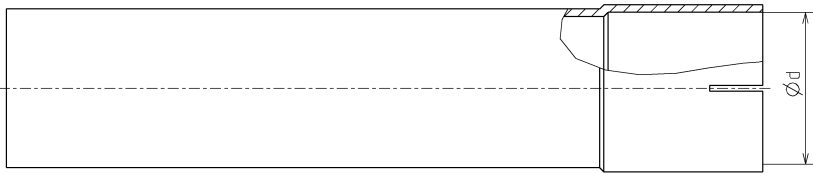

Specification 1: Adding a 20-centimeter linear extension to the exhaust pipe

Version 2

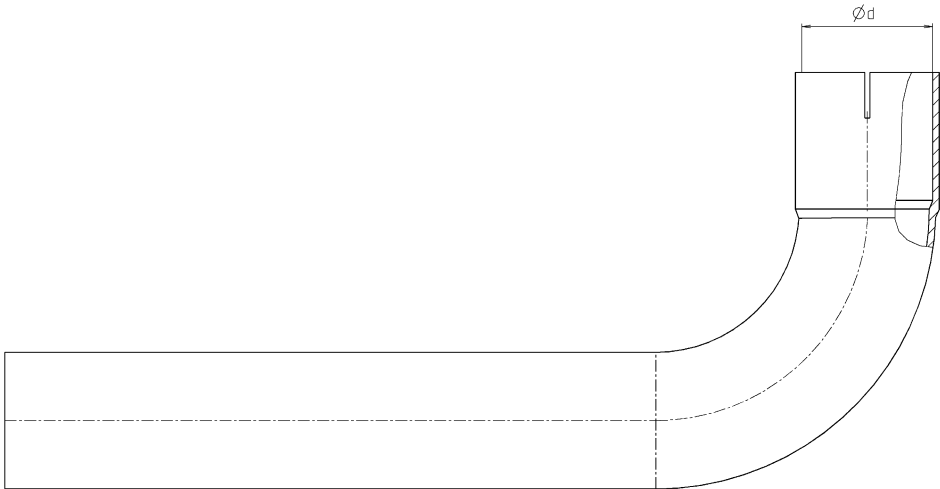

Specification 2: Adding a 20-centimeter bended extension to the exhaust pipe

Engine type	$\varnothing d$ (mm)	Version 1 HATZ-Ident. Nr.	Version 2 HATZ-Ident. Nr.	Clamp HATZ-Ident. Nr.
2G40 (H)	40	830 582 00	830 853 00	503 398 00

CALIFORNIA

Proposition 65 Warning

Diesel engine exhaust and some of its constituents are known to the State of California to cause cancer, birth defects, and other reproductive harm.