

**CONTINENTAL  
POWER UNITS  
TMD20 • TMD27 • TM20 • TM27**

---

**ILLUSTRATED  
PARTS  
CATALOG &  
ASSEMBLY MANUAL**

**P  
O  
W  
E  
R  
  
U  
N  
I  
T  
S**



**WISCONSIN  
MOTORS, LLC**

---

2020 Fletcher Creek Drive, Memphis, Tennessee 38133  
[www.wisconsinmotors.com](http://www.wisconsinmotors.com)  
(800) 932-2858

# SERVICE FACILITIES

Wisconsin Motors, LLC Distributors and Service Centers, located throughout the U.S. and foreign countries, have been carefully selected to insure complete and efficient repair and inspection service to owners of Wisconsin Motors, LLC Power Units. These service centers, equipped and staffed for complete power unit repair and assembly, also stock engine parts to facilitate immediate delivery for the complete line of Wisconsin Motors, LLC Engines.

Order parts from the Wisconsin Motors, LLC Distributor or Service Center in your locality. Refer to the Yellow Pages of the Telephone Directory under ENGINES, visit [www.wisconsinmotors.com](http://www.wisconsinmotors.com) and look under Distributors or write Wisconsin Motors, LLC for a free copy of a list of authorized Distributors and Service Centers. Do not order parts from Wisconsin Motors, LLC in Memphis, Tennessee.

The SPECIFICATION NUMBER of your power unit must be given when ordering parts. The SPECIFICATION NUMBER is on the name plate.

Copy the SPECIFICATION NUMBER in the space provided below so that it will be available when ordering parts.

When ordering ENGINE PARTS refer to the appropriate parts list for the model and specification listed on the engine name plate.

MODEL

SPECIFICATION NUMBER

To insure prompt and accurate service, the following information must also be given:

1. State EXACTLY the quantity of each part and part number.
2. State definitely whether parts are to be shipped by express, freight or parcel post.
3. State exact mailing address.

# INTRODUCTION

This catalog is designed to identify Wisconsin Motors, LLC Power Unit parts and to illustrate assembly methods for various power unit kits.

The included installation drawings, wiring diagrams and kits define the configurations required to build a range of TM/TMD open (OPU) and closed (CPU) power units. All dimensions are inches unless otherwise shown.

These power units are designed to be used with gasoline, LPG or natural gas TM20/TM27 engines or diesel TMD20/TMD27 engines. These power units are limited to engines with SAE #4 bellhousing only.

When ordering parts for an existing power unit, it is always advisable to list the power unit number. With this information we can check your order for any incorrect part numbers. Use your service parts list to insure proper number and nomenclature identification. If parts are required to build new power units, see the example on the following pages.

Wisconsin Motors, LLC reserves the right to modify, alter and improve engines and parts. Part numbers and the structure of parts may change from those shown in this catalog.

# POWER UNIT CONFIGURATION

An example showing the kits necessary to build a standard CPU (closed power unit) with a TMD27 engine is as follows:

KIT PART #	DESCRIPTION
---	Base engine with SAE #4 flywheel and flywheel housing
1020100	Engine mounting kit
TM4T00114	Exhaust flange kit
10101001	Fan kit
10101002	Radiator kit
TM4T00106	Fan guard kit
10051001	Muffler kit
10231041	Instrument kit -full
10271002	Enclosure kit
TM4T00110	Air cleaner kit
10221005	Air cleaner hose kit
10271001	Side panel kit

To build the above power unit with specific options, the following kits may be added as desired:

KIT PART #	DESCRIPTION
10231040	Instrument kit-optional -REPLACE1S0 231041 kit
10211009	Fuel tank kit
10121004	Battery box kit
10281001 or 10281002	Power take-off dutch kit  Power take-off clutch kit

Any questions concerning the content of the kits or how they may be assembled to obtain a specific power unit configuration should be directed to:

Wisconsin Motors, LLC  
2020 Fletcher Creek Drive, Memphis, Tennessee 38133  
www.wisconsinmotors.com  
(800) 932-2858

# INDEX

Installation Drawings .....	1-4
Power Take-Off .....	5-6
Wiring Diagrams and Harnesses .....	7-14
Radiator .....	15
Fan Guard .....	16
Fan and Muffler Mounting .....	18-20
Mounting Base .....	21-22
Side Panels .....	23
Enclosure - Open Power Unit .....	24
Enclosure - Closed Power Unit .....	25-26
Fuel Tank .....	27-28
Instrument Mounting - Full Instrumentation .....	30-34
Instrument Mounting - Optional Instrumenation .....	36-40
Fuse Block and Solenoid .....	41
Air Cleaners .....	42-46
Battery Mounting .....	47

# Closed Power Unit TM/TMD 20

## P/N ID 1533

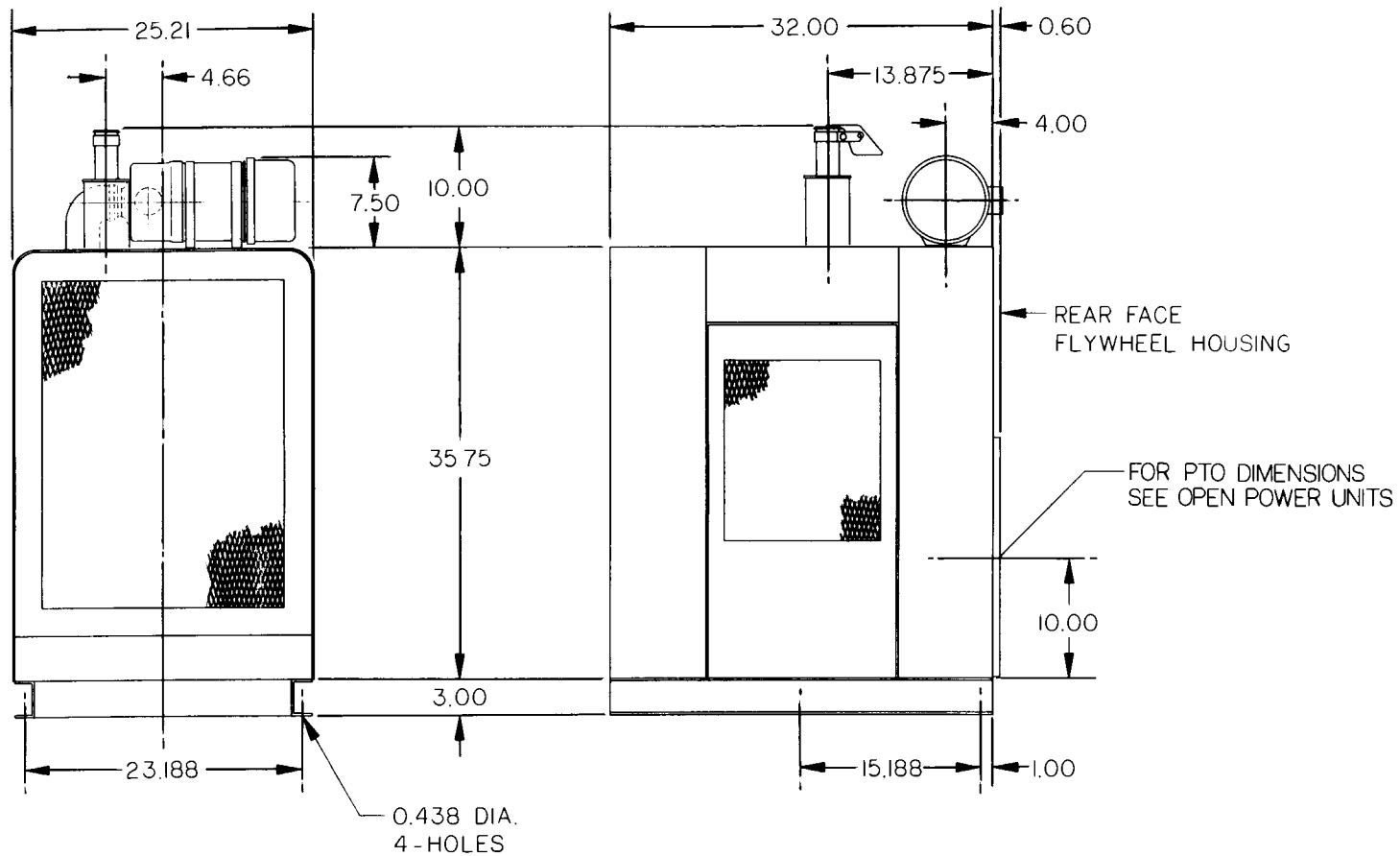

# Closed Power Unit TM/TMD 27

## P/N ID 1534

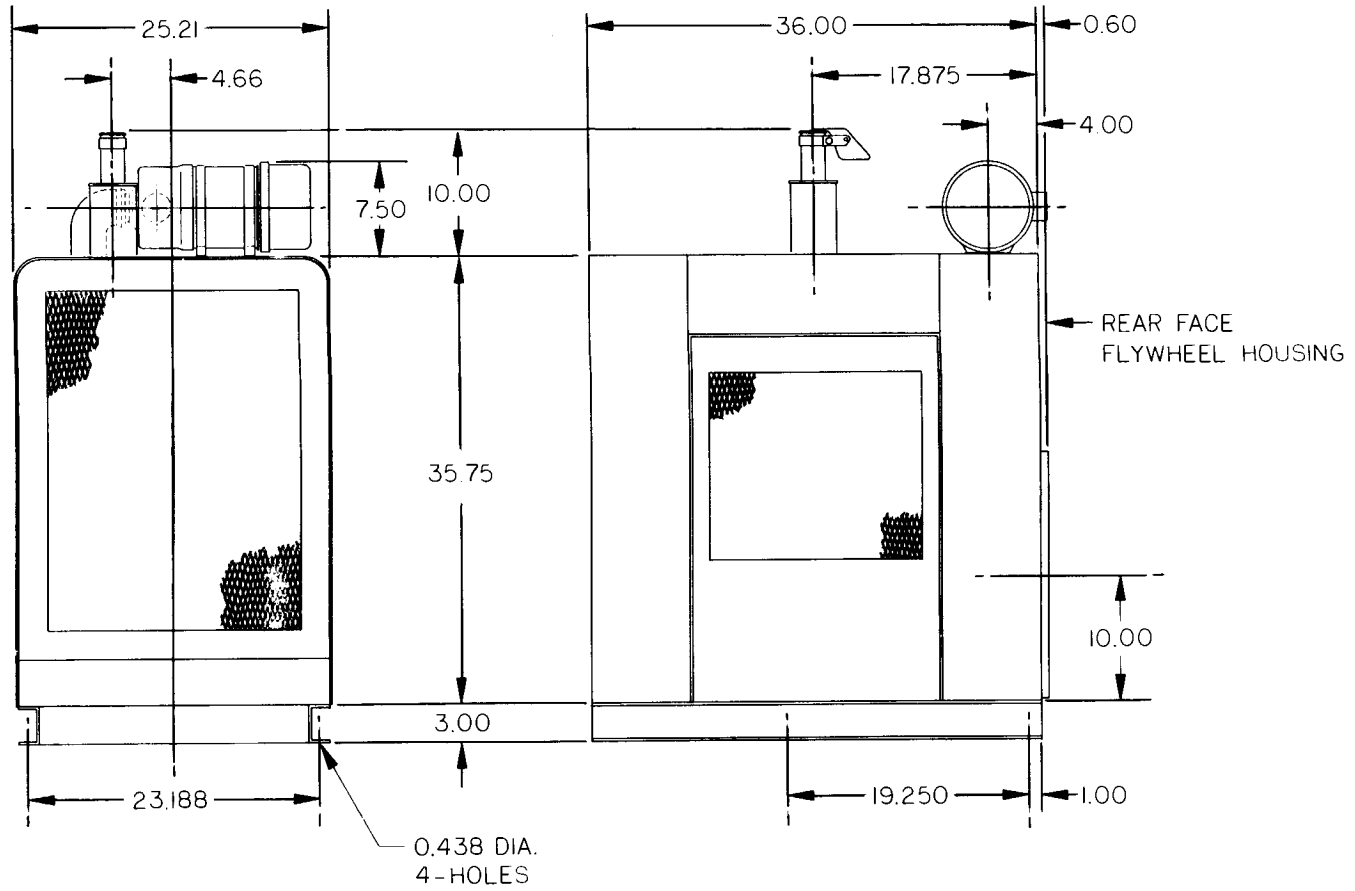

# Open Power Unit TM/TMD 20

## P/N ID 1543

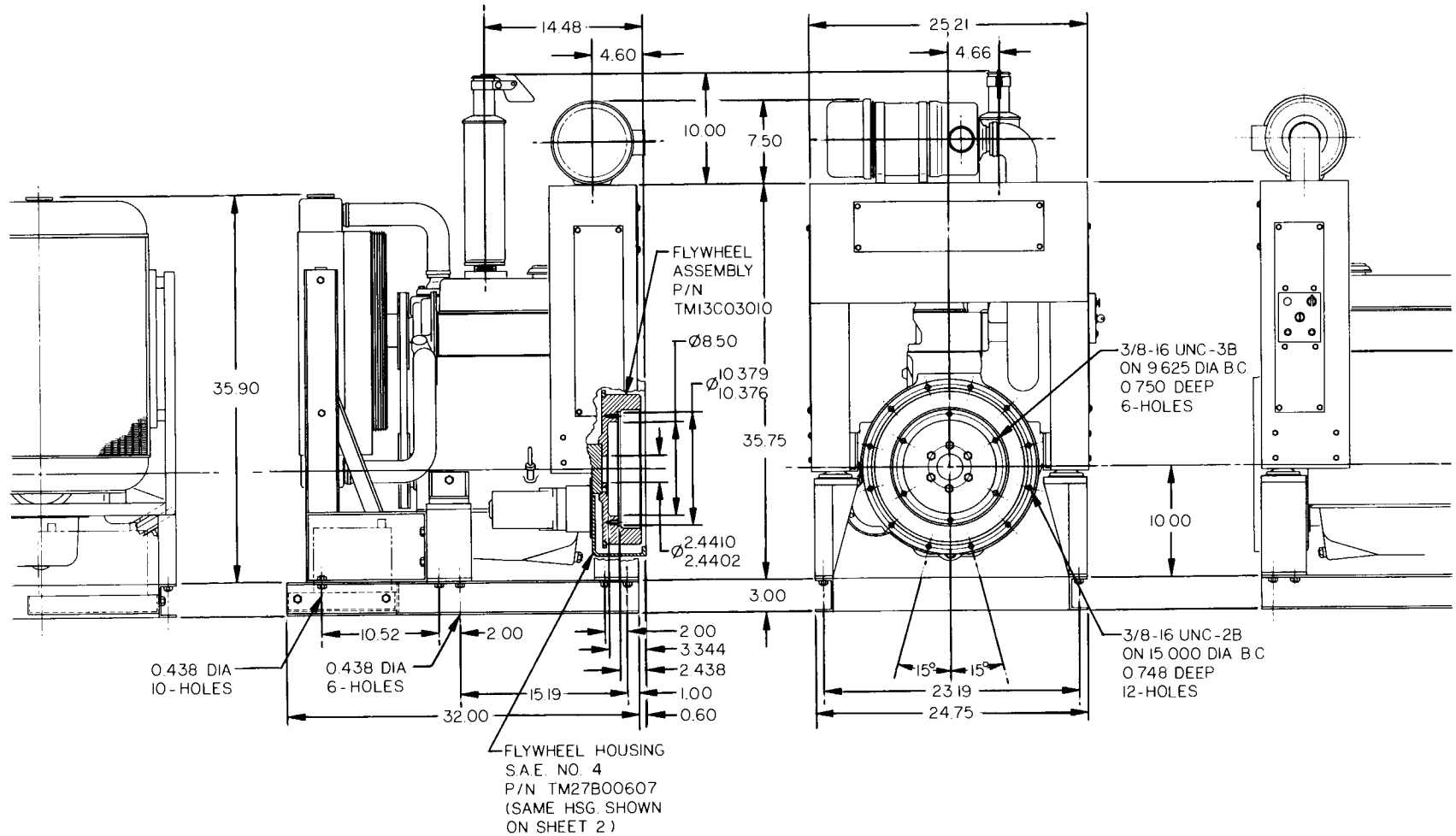



# Open Power Unit TM/TMD27

## P/N ID 1544

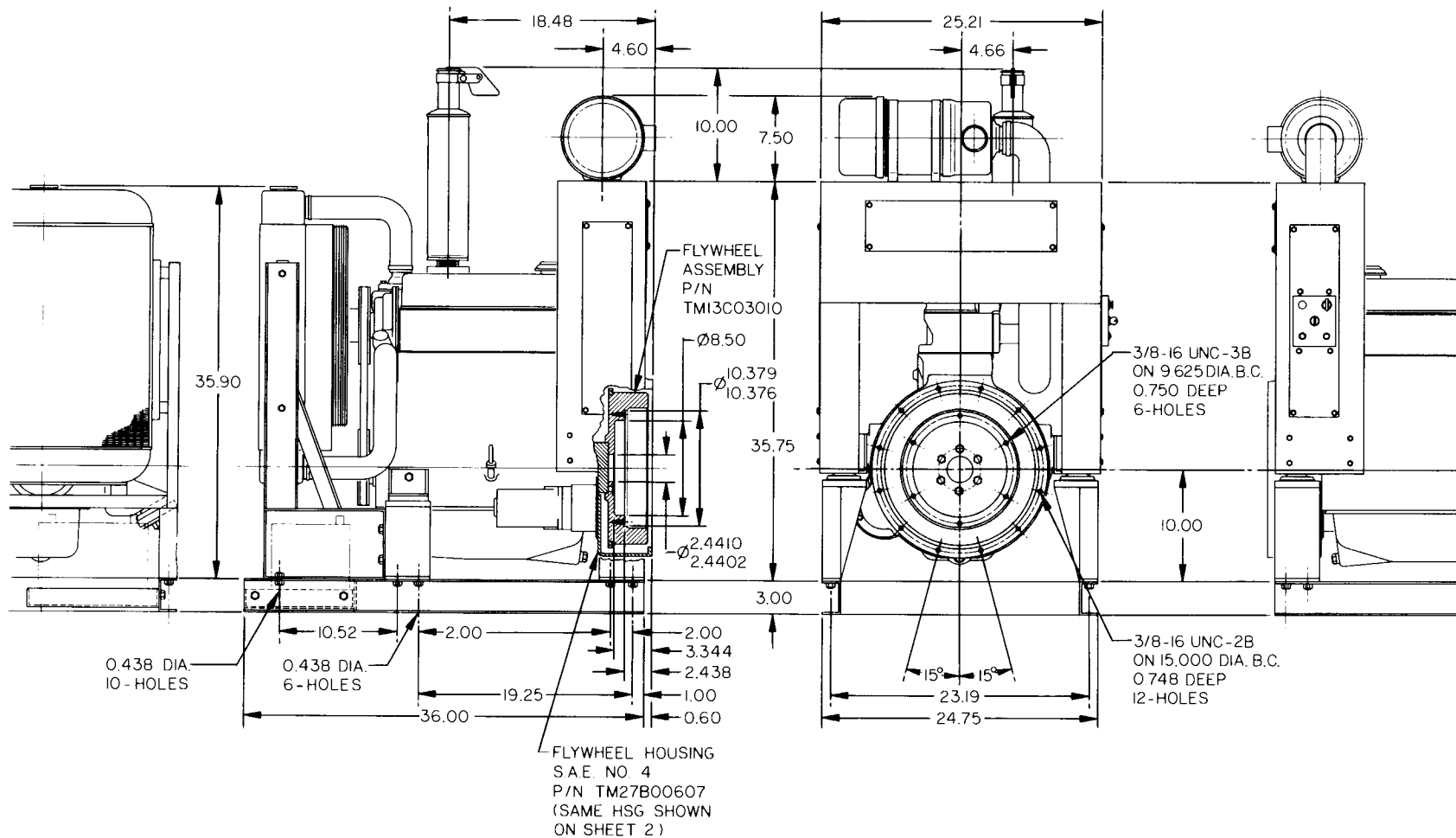

# Open Power Unit TM/TMD 20 & 27

## P/N ID 1544

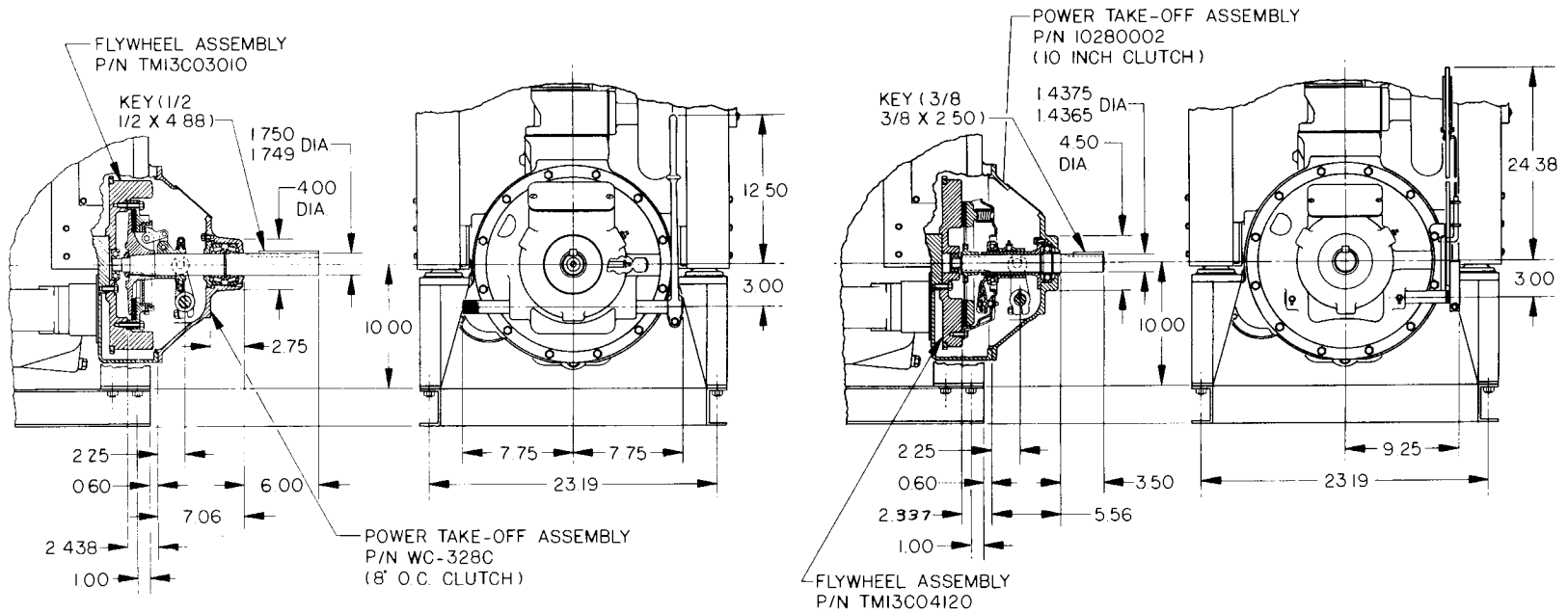

## Power Take-Off Clutch Kits

(see page 5)

ITEM	PART NO.	DESCRIPTION	QTY
—	10281002	Power take-off clutch kit (includes the following) .....	1
	10280002	Power take-off clutch (10" spring loaded) .....	1
	13XX14141	Washer, plain, 3/8 HC10002 .....	12
	X00203	Washer, lock, 3/8 HC10004 .....	12
	XD29	Screw, 3/8-16 x 1-1/4 .....	12

ITEM	PART NO.	DESCRIPTION	QTY
—	10281001	Power take-off clutch kit (includes the following) .....	1
	WC328C1S1	Power take-off clutch (8" over-center) .....	1
	XD29	Screw, 3/8-16 x 1-1/4 .....	18
	X00203	Washer, lock .....	18

ITEM	PART NO.	DESCRIPTION	QTY
—	* 10281003	Kit, stubshaft (not shown) (includes the following) .....	1
	TM27C00418	Stubshaft .....	1
	XM32114	Bolt, M10 x 45 mm LG. ....	6

\* Note:       -Only good for in-line hook up with flexible coupling.

-To install stubshaft, remove existing flywheel mounting bolts, mount stubshaft and flywheel using longer bolt XM32114. Schematic of kit 10281003 not included.

# Wiring Diagram for Full Instrumentation Harness TM Engines P/N 10120056

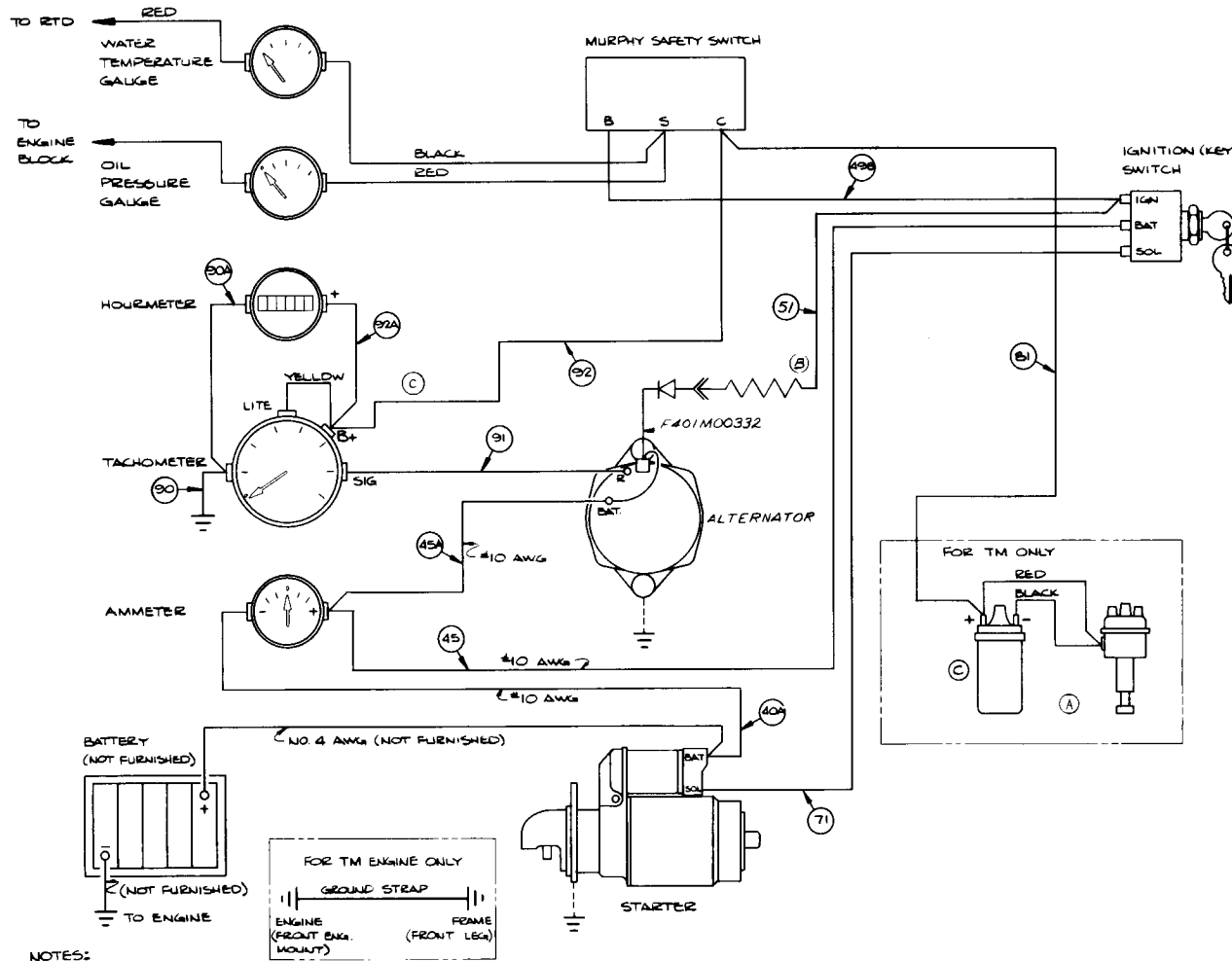

**NOTES:**

1. ALL WIRES #10 AWG UNLESS NOTED.
2. INTERNAL GROUND.
3. THIS DIAGRAM SHOWS ALL OPTIONAL GAUGES - CERTAIN UNITS MAY BE DELETED BY CUSTOMER.

# Wiring Harness for Full Instrumentation TM Power Unit P/N 10120046

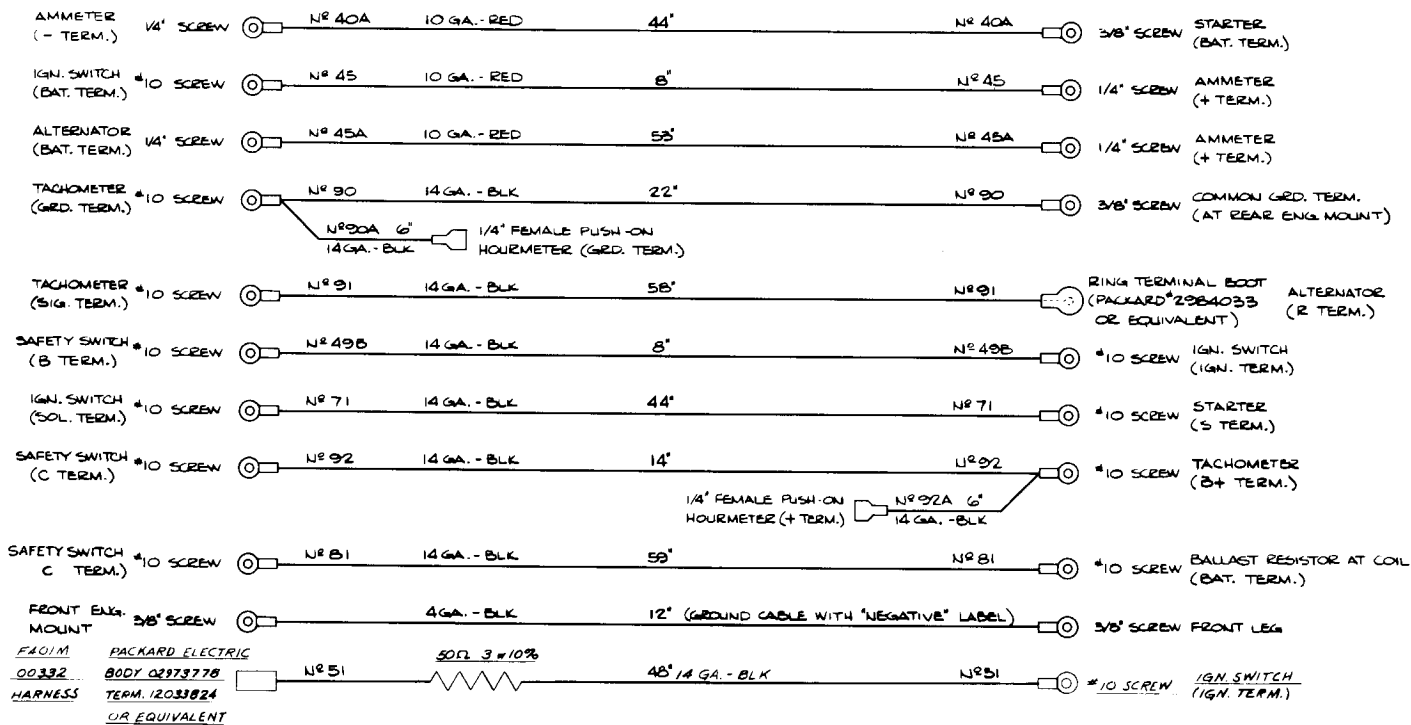

**NOTES:**

1. CABLE - GENERAL PURPOSE THERMOPLASTIC INSULATED STRANDED COPPER PER SAE J1128, TYPE G1PT.
2. TERMINAL ENDS PER SAE J561 & MUST BE INSULATED.
3. CABLE 16' AND LONGER TO HAVE WIRE N° SHOWN ON BOTH ENDS.
4. TTP TO FURNISH VENDOR WITH PACKAGING BOX (Y3255) AND BAR CODE LABEL.
5. HARNESS TO BE SLEEVED WITH BRAIDED PVC COATED NYLON THREAD

# Wiring Diagram for Full Instrumentation Harness TMD Engines P/N 10120054

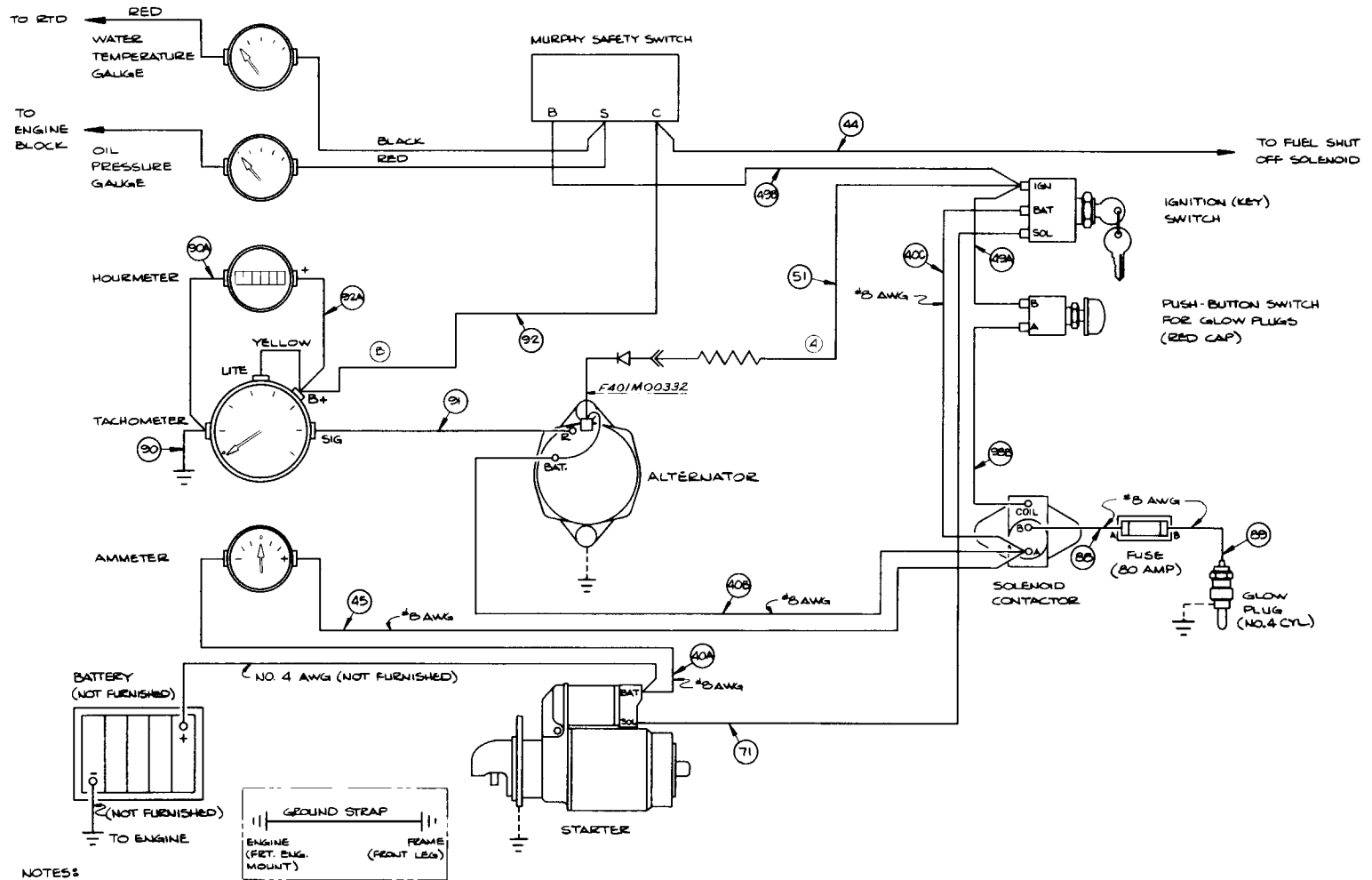

- NOTES:
1. ALL WIRES #14 AWG UNLESS NOTED.
  2. INTERNAL GROUND.
  3. THIS DIAGRAM SHOWS ALL OPTIONAL GAUGES - CERTAIN UNITS MAY BE DELETED BY CUSTOMER.

# Wiring Harness for Full Instrumentation TMD Power Unit P/N 10120048

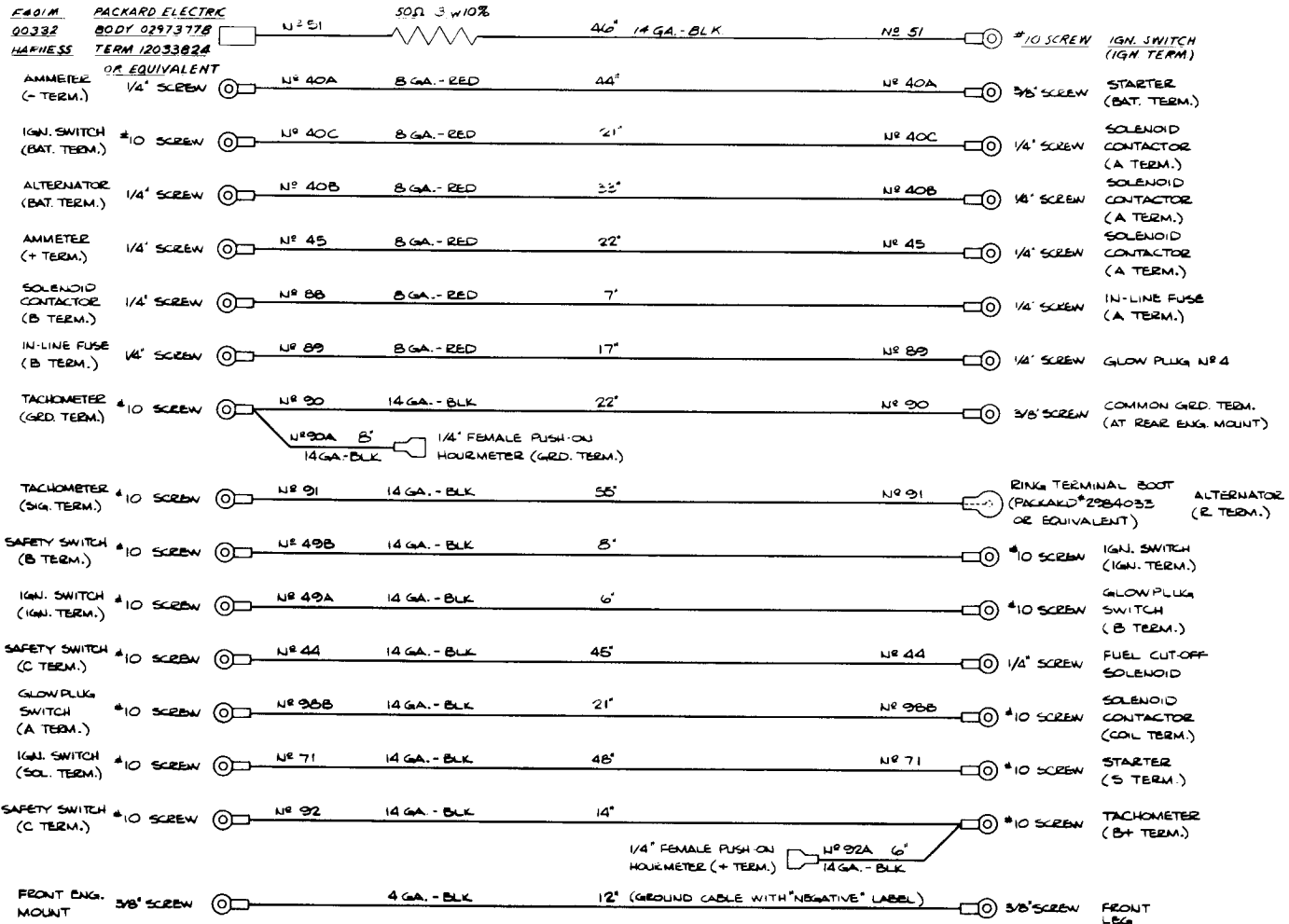

**NOTES:**

1. CABLE - GENERAL PURPOSE THERMOPLASTIC INSULATED STRANDED COPPER PER J112B, TYPE GPT.
2. TERMINAL ENDS PER SAE J561 & MUST BE INSULATED.
3. CABLES 16" AND LONGER TO HAVE WIRE N° SHOWN ON BOTH ENDS.
4. TTP TO FURNISH VENDOR WITH PACKAGING BOX (Y3255) AND BAR CODE LABEL.
5. HARNESS TO BE SLEEVED WITH BRAIDED PVC COATED NYLON THREAD.

# Wiring Diagram for Optional Harness TM Engines P/N 10120055

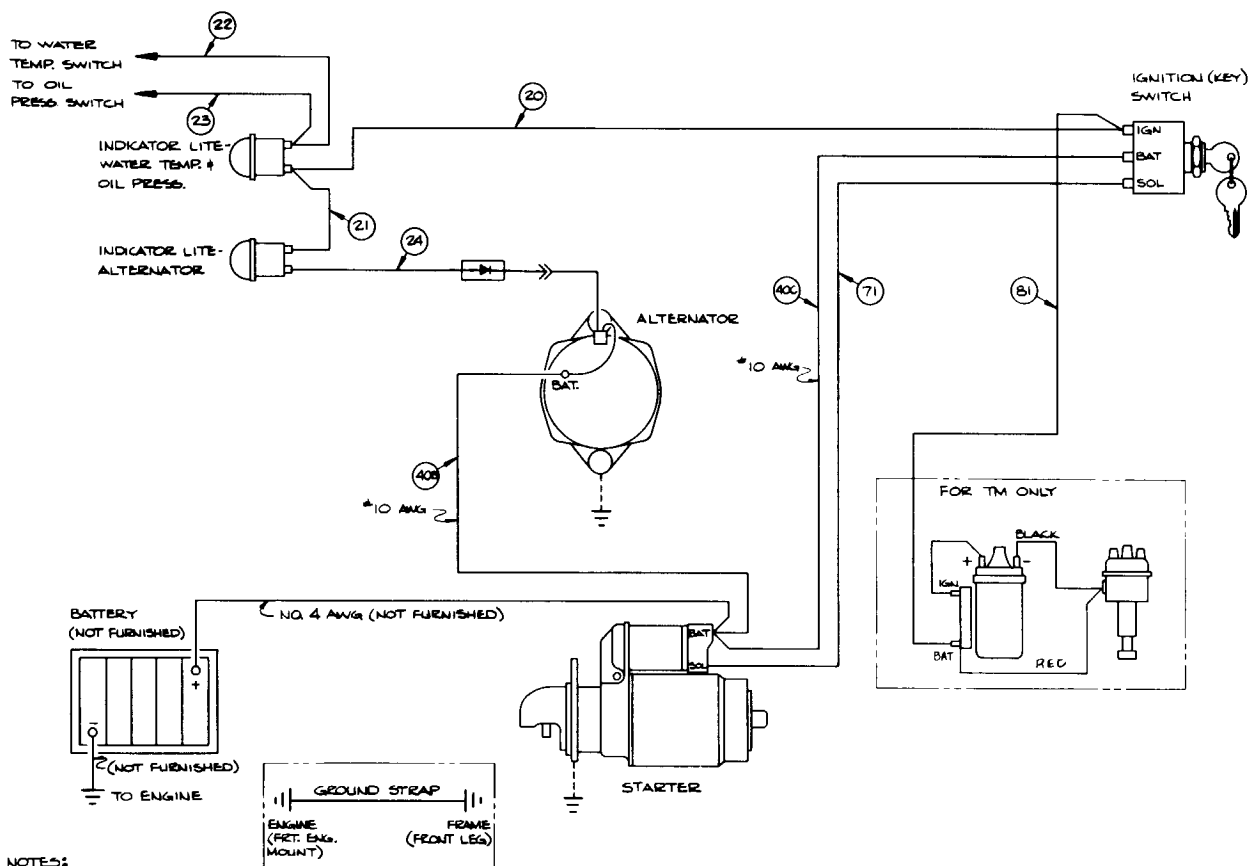

**NOTES:**

1. ALL WIRE #14 AWG UNLESS NOTED.
2. INTERNAL GROUND
3. PUSH ON CONNECTOR - FEMALE
4. PUSH ON CONNECTOR - MALE



# Wiring Harness for Optional Instrumentation TM Power Unit P/N 10120045

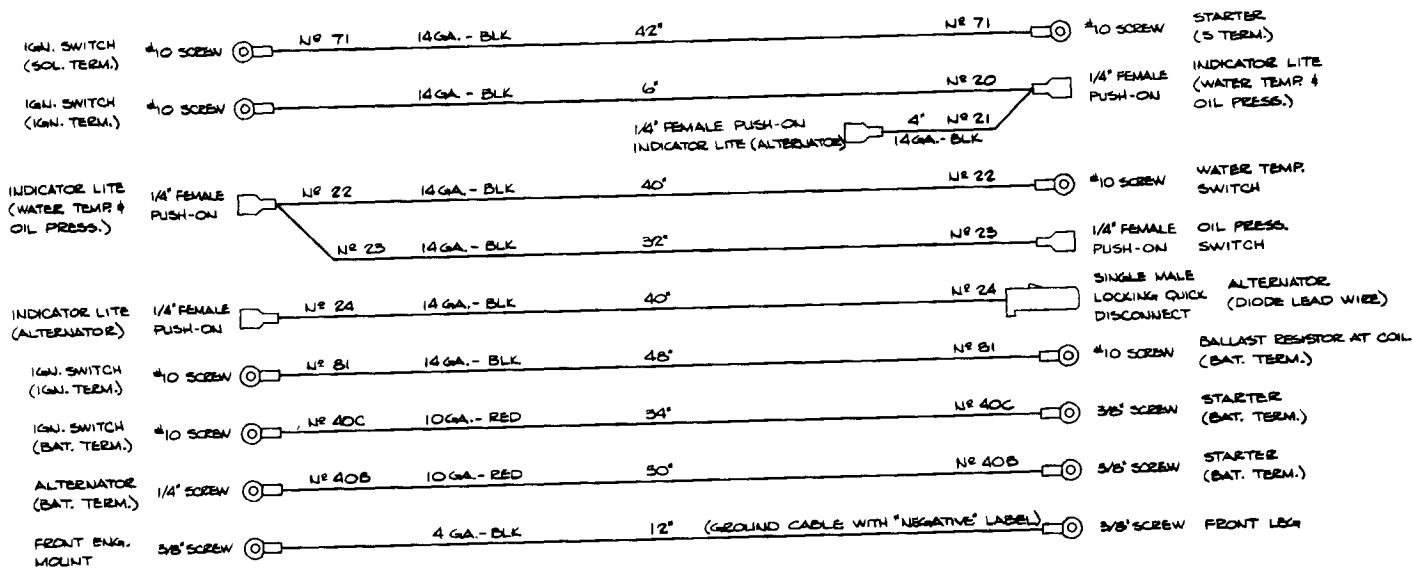

## NOTES:

1. CABLE - GENERAL PURPOSE THERMOPLASTIC INSULATED STRANDED COPPER PER SAE J1126, TYPE GPT.
2. TERMINAL ENDS PER SAE J561 & MUST BE INSULATED.
3. CABLES 16" AND LONGER TO HAVE WIRE NO SHOWN ON BOTH ENDS.
4. TTP TO FURNISH VENDOR WITH PACKAGING BOX (Y3255) AND BAR CODE LABEL.

# Wiring Diagram for Optional Harness TMD Engines P/N 10120053

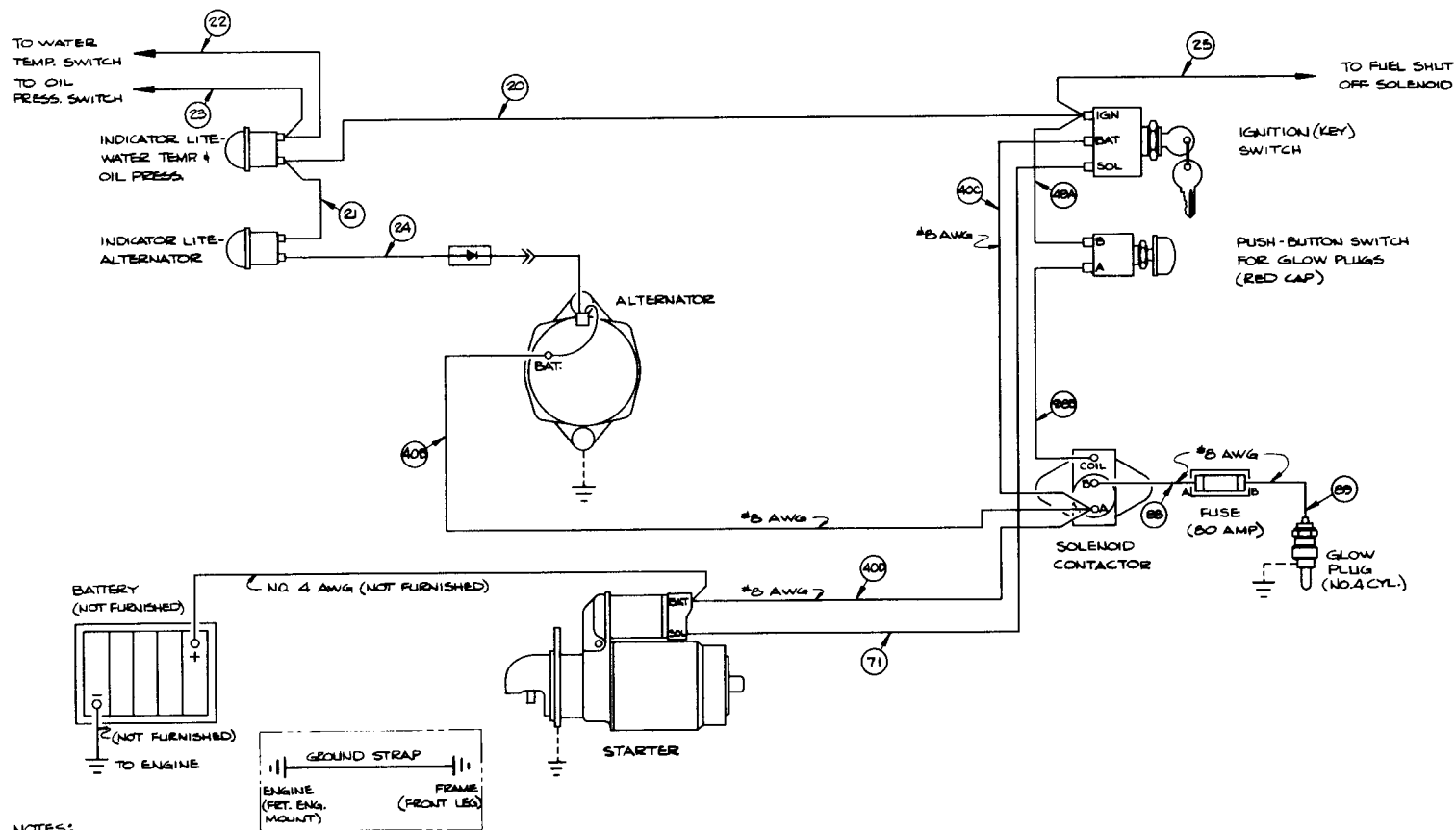

**NOTES:**

1. ALL WIRE #14 AWG UNLESS NOTED.
2. --- INTERNAL GROUND
3. ——— PUSH ON CONNECTOR - FEMALE
4. ——— PUSH ON CONNECTOR - MALE

# Wiring Harness for Optional Instrumentation TMD Power Unit P/N 10120047

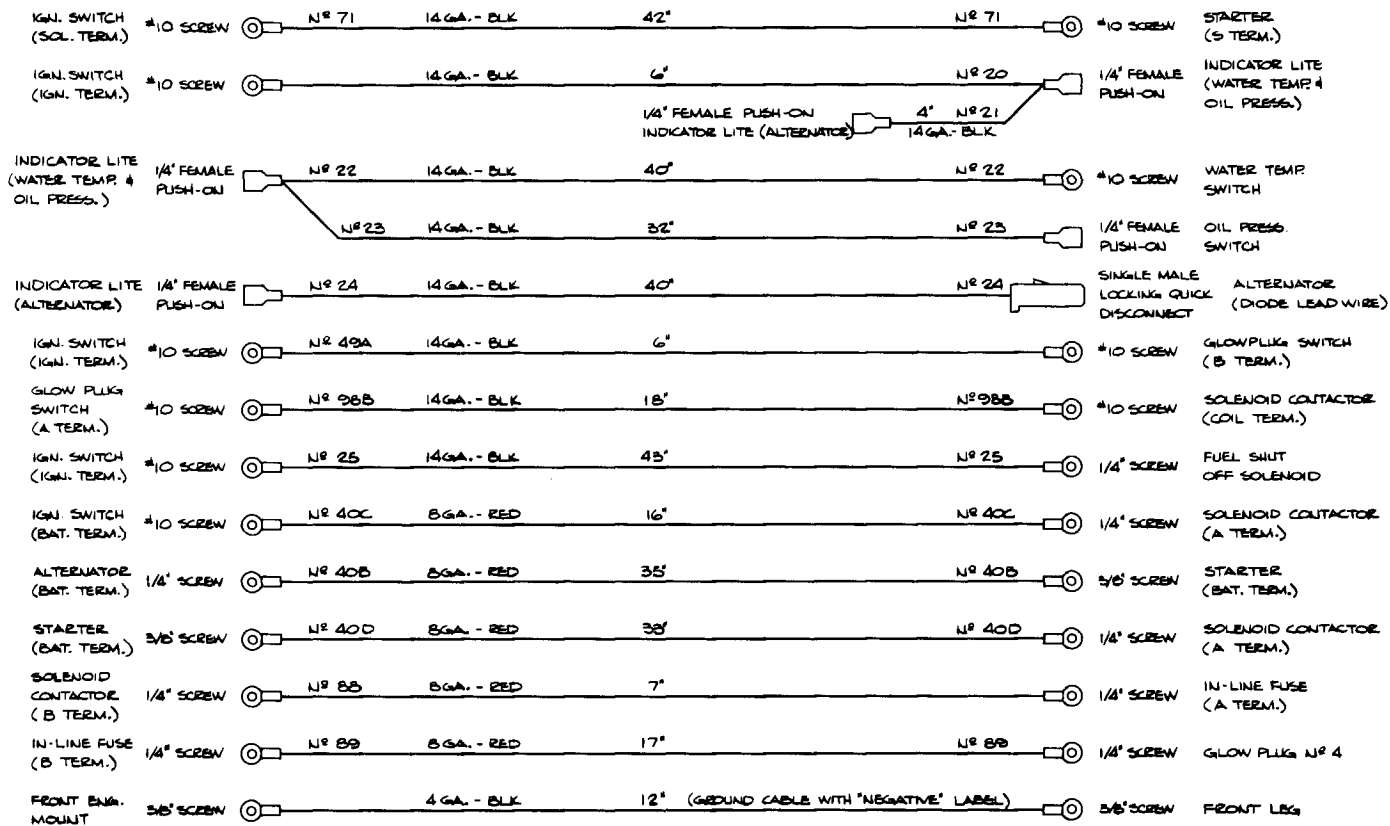

**NOTES:**

1. CABLE - GENERAL PURPOSE THERMOPLASTIC INSULATED STRANDED COPPER PER SAE J112B, TYPE GPT.
2. TERMINAL ENDS PER SAE J1561 & MUST BE INSULATED.
3. CABLES 16" AND LONGER TO HAVE WIRE Nº SHOWN ON BOTH ENDS.
4. TTP TO FURNISH VENDOR WITH PACKAGING BOX (Y325) AND BAR CODE LABEL.

## Radiator Kit — TM/TMD

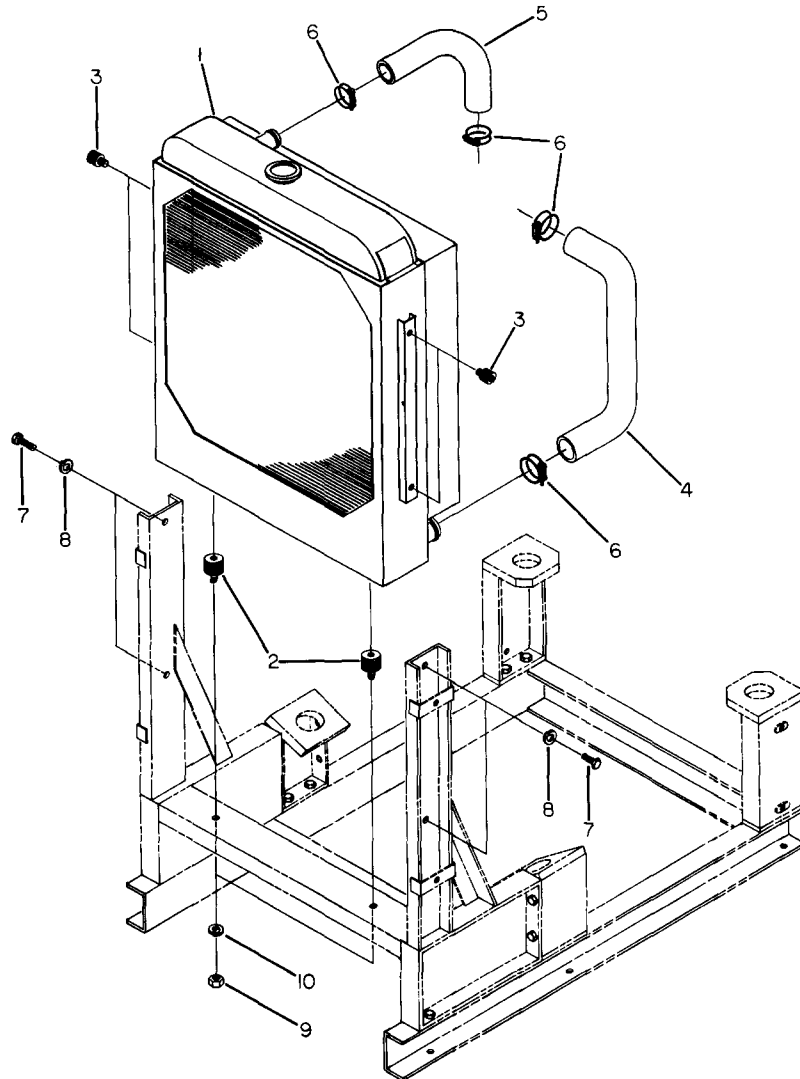

ITEM	PART NO.	DESCRIPTION	QTY
—	10101002	Radiator kit (includes 1 thru 10).....	1
1	10100009	Radiator — TM/TMD.....	1
2	10100005	Lower radiator mounts.....	2
3	10100004	Upper radiator mounts.....	4
4	10200033	Hose - lower radiator - molded.....	1
5	10200032	Hose - upper radiator - molded.....	1
6	X02463	Hose clamp, 2".....	4
7	X03236	Screw, 5/16-18 x 1/2.....	4
8	X00202B	Washer, lock, 5/16.....	4
9	X01802G	Nut, 3/8.....	2
10	X00203	Washer, lock, 3/8.....	2

## Fan Guard Kit — TM/TMD

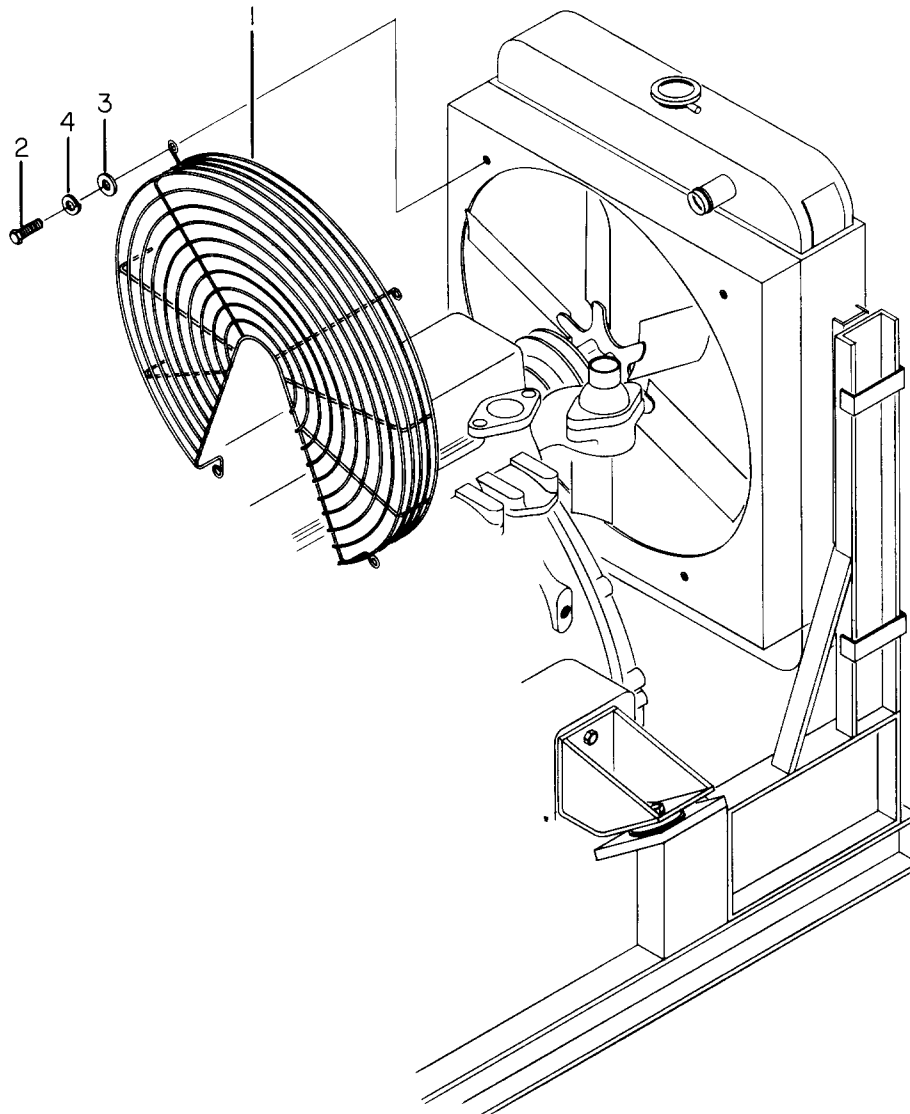

ITEM	PART NO.	DESCRIPTION	QTY
—	TM4T00106	Fan guard kit (includes 1 thru 4) .....	1
1	TM27K00421	Fan guard .....	1
2	X03158	Screw, 5/16 - 18 x 5/8 .....	4
3	X14219	Washer, plain, 5/16 .....	4
4	X00202B	Washer, lock, 5/16 .....	4

## Notes:

# Fan Kit

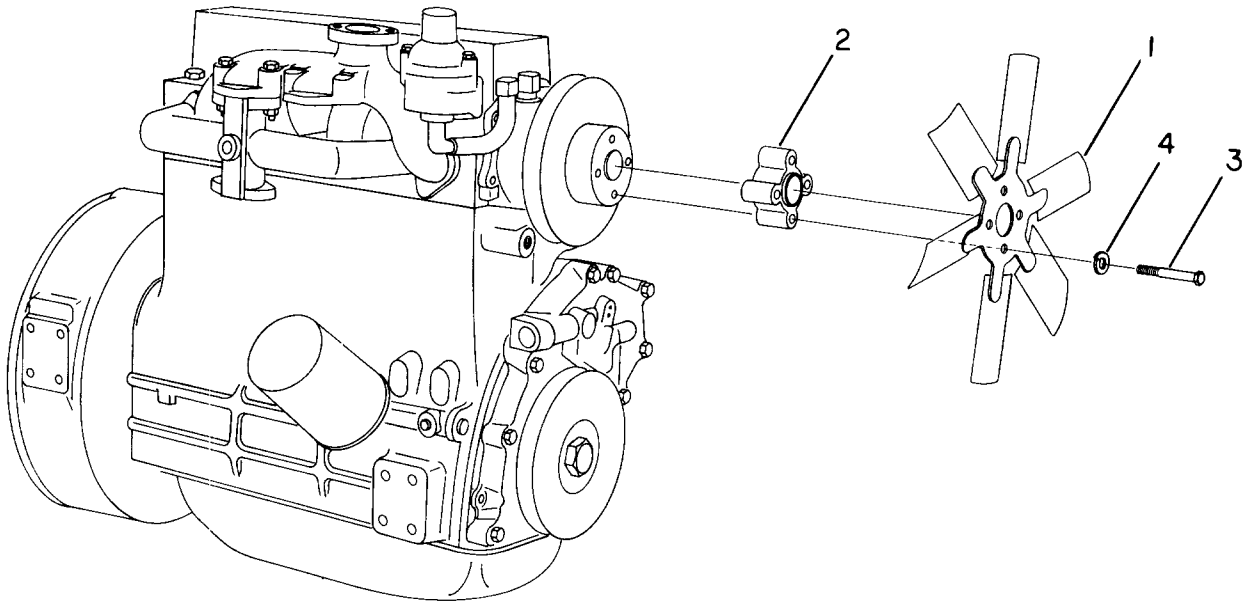

## 10101001 Kit

ITEM	PART NO.	DESCRIPTION	QTY
—	10101001	Puller fan kit (includes 1 thru 4) .....	1
1	F163K00222	6 Blade puller fan, 17" .....	1
2	10100010	Fan spacer, 1.25" long .....	1
3	XM32005	Screw, M8 x 1.25 x 50 mm long .....	4
4	XM37002	Washer, lock, M8 .....	4

# Muffler Kit

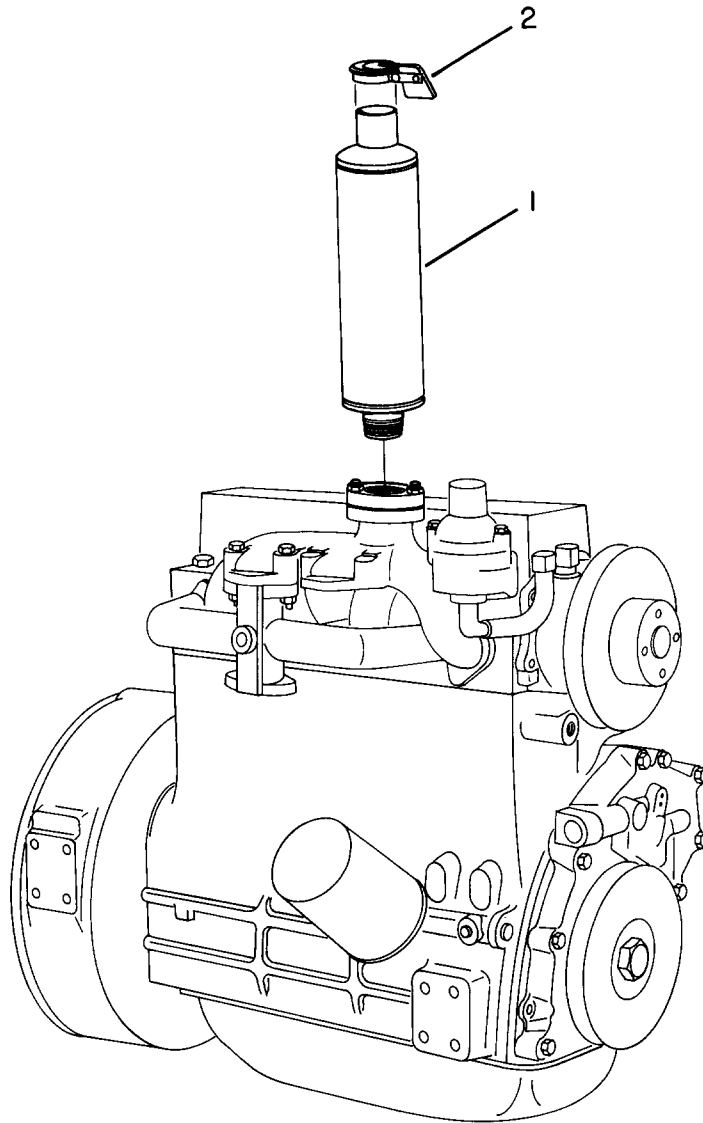

## 10051001 Kit

ITEM	PART NO.	DESCRIPTION	QTY
—	10051001	Muffler kit (includes 1 and 2) .....	1
1	10050004	Muffler .....	1
2	TM27P00308	Weather cap.....	1



# Muffler Mounting Kit

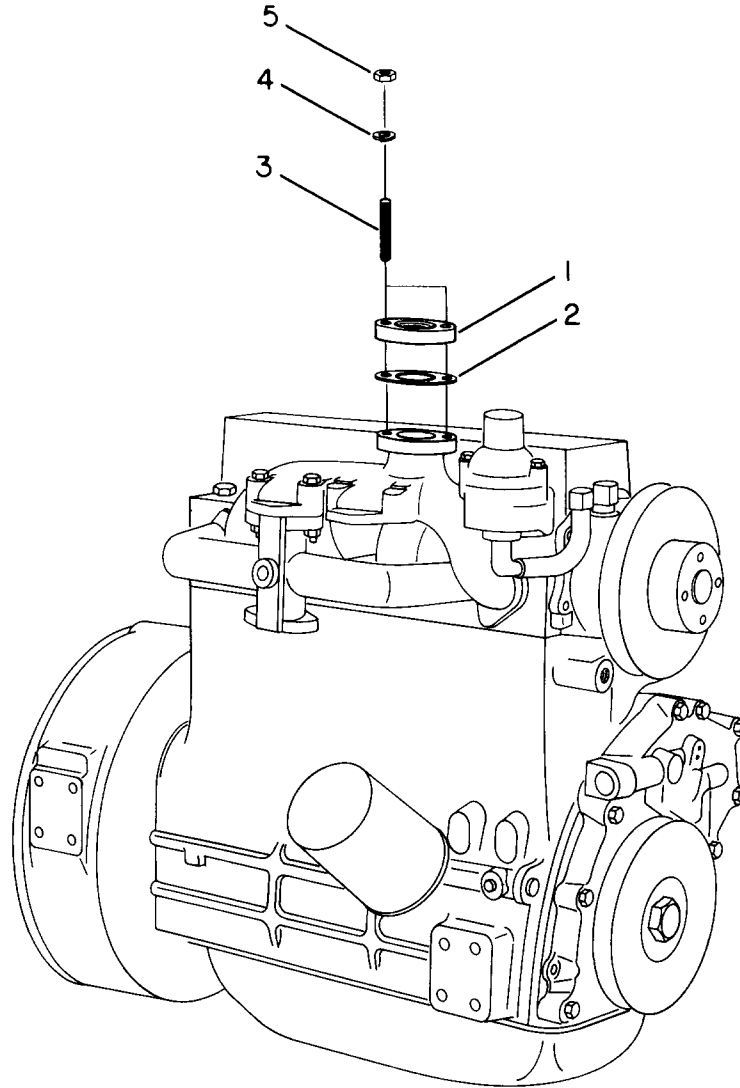

## TM4T00114 Kit

ITEM	PART NO.	DESCRIPTION	QTY
—	TM4T00114	Exhaust flange kit (includes 1 thru 5) .....	1
1	F226E00212	Exhaust manifold flange .....	1
2	X07864	Exhaust outlet gasket .....	1
3	XM32048	Stud, M10 x 40 long HCM10007 .....	2
4	XM37001	Washer, lock, M10 .....	2
5	24XXM35000	Nut, hex, M10 .....	2

# Engine Mounting Kit — TM/TMD20, TM/TMD27

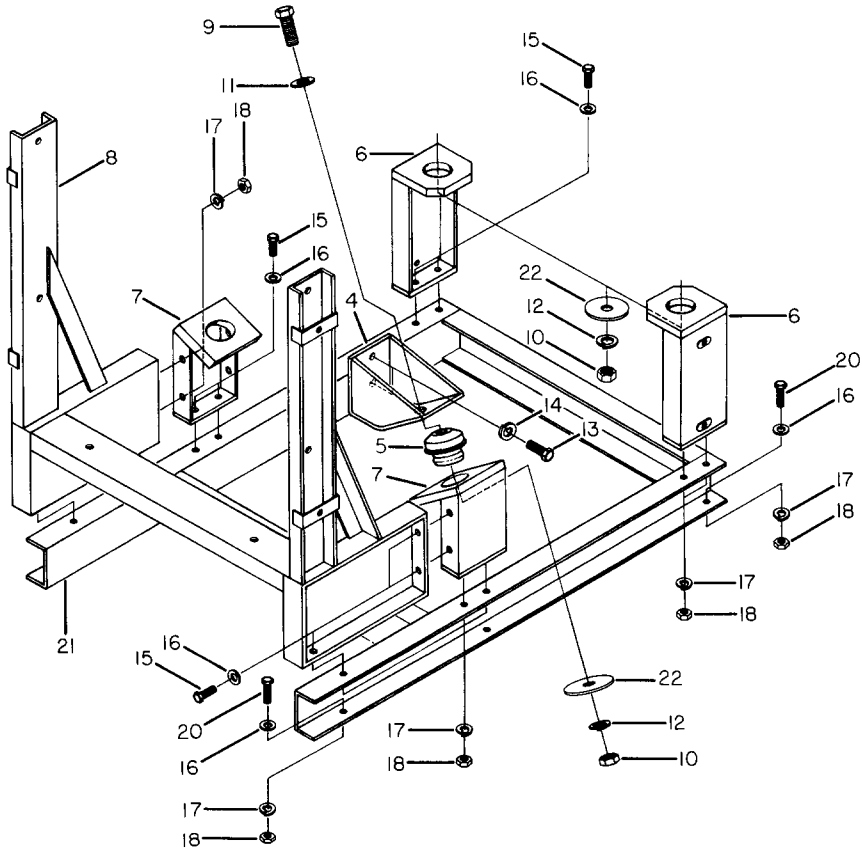
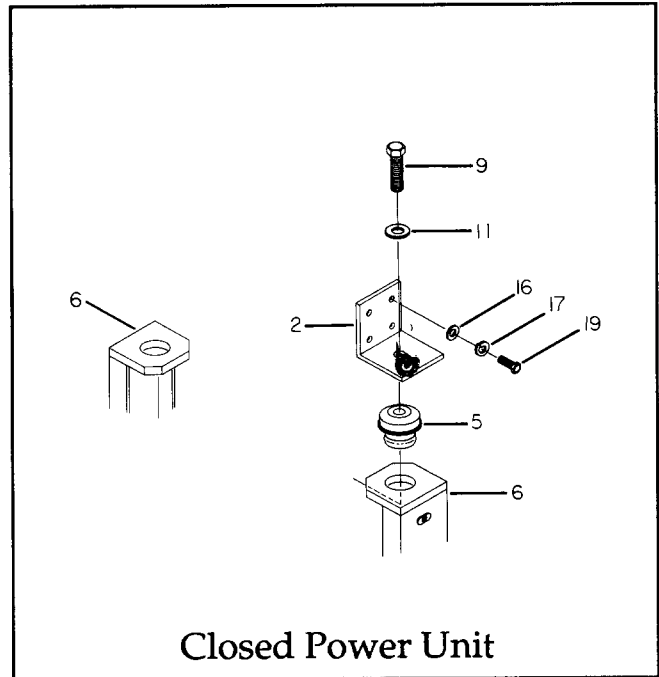
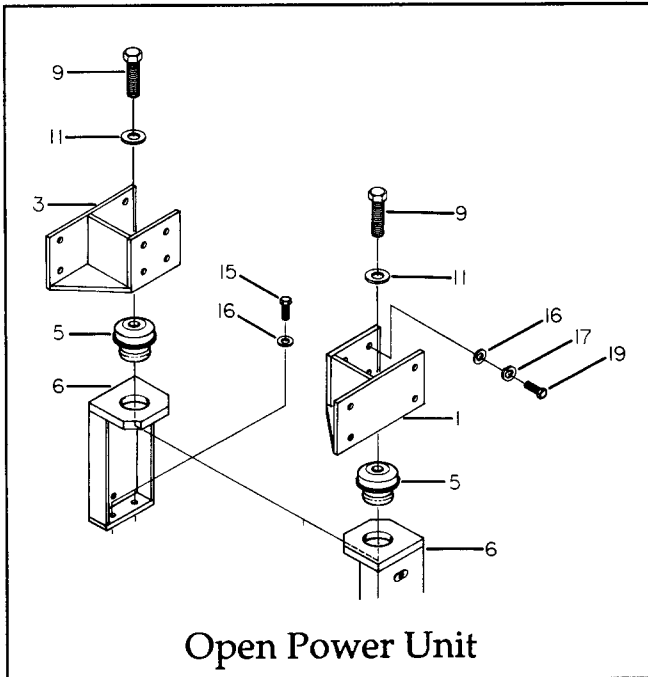

Continental Power Units

# Engine Mounting Kit — TM/TMD20, TM/TMD27

ITEM	PART NO.	DESCRIPTION	QTY			
			OPU		CPU	
			TM20 TMD20	TM27 TMD27	TM20 TMD20	TM27 TMD27
			(1)	(2)	(3)	(4)
—	10201006	Engine mounting kit - TM/TMD20 OPU includes items in column (1)	1			
—	10201005	Engine mounting kit - TM/TMD27 OPU includes items in column (2)		1		
—	10201004	Engine mounting kit- TM/TMD20 CPU includes items in column (3)			1	
—	10201003	Engine mounting kit- TM/TMD27 CPU includes items in column (4)				1
1	10200012	Rear engine mounting bracket - OPU left hand side	1	1		
2	10200004	Rear engine mounting bracket CPU			2	2
3	10200013	Rear engine mounting bracket - OPU right hand side	1	1		
4	10200003	Front engine mounting bracket	2	2	2	2
5	10200001	Engine mounts	4	4	4	4
	10200016	Solid engine mount (optional)	4	4	4	4
6	10200006	Rear legs	2	2	2	2
7	10200011	Front legs	2	2	2	2
8	10100011	Radiator support - TM/TMD	1	1	1	1
9	X22147	Screw, 3/4-10 x 3-1/2	4	4	4	4
10	X01897	Nut, 3/4	4	4	4	4
11	X14120	Washer, flat 3/4	4	4	4	4
12	X00256	Washer, lock, 3/4	4	4	4	4
13	XM32101	Screw, M14 x 2 x 25 mm long	4	4	4	4
14	X00215	Washer, lock, 9/16	4	4	4	4
15	X03063	Screw, 3/8-16 x 1-1/4 long	14	14	14	14
16	X14472	Washer, flat, 3/8	26	26	26	26
17	X00203	Washer, lock, 3/8	26	26	26	26
18	X01802G	Nut, 3 /8-16	18	18	18	18
19	X03942	Screw, 3/8-16 x 1 long	8	8	8	8
20	X03258	Screw, 3/8-16 x 1-1/2 long	4	4	4	4
21	10270016	Mounting base - TM/TMD27		1		1
—	10270017	Mounting base - TM/TMD20	1		1	
22	10200002	Washer, engine mounting	4	4	4	4

## Side Panel Kit — TM/TMD

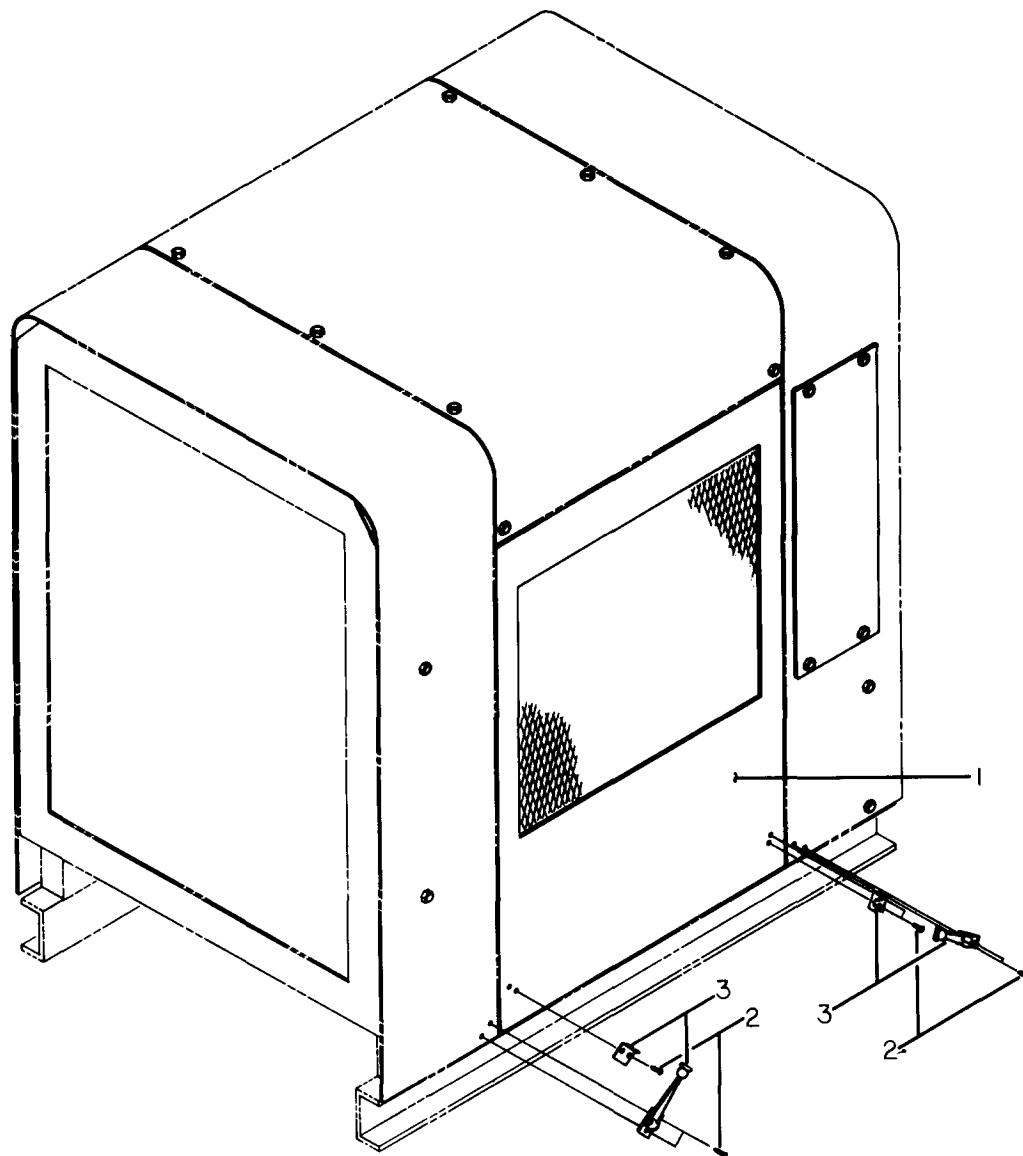

ITEM	PART NO.	DESCRIPTION	QTY	
			TM/TMD27 (1)	TM/TMD20 (2)
—	10271001	Side panel kit - TM/TMD27 includes items in column (1)	1	
—	10271008	Side panel kit - TM/TMD20 includes items in column (2)		1
1	10270015	Side panel - TM/TD27	2	
	10270014	Side panel - TM/TMD20		2
2	XA119	Screw, self tapping	16	16
3	10200008	Side panel fastener	4	4

# Enclosure Kit — TM/TMD OPU

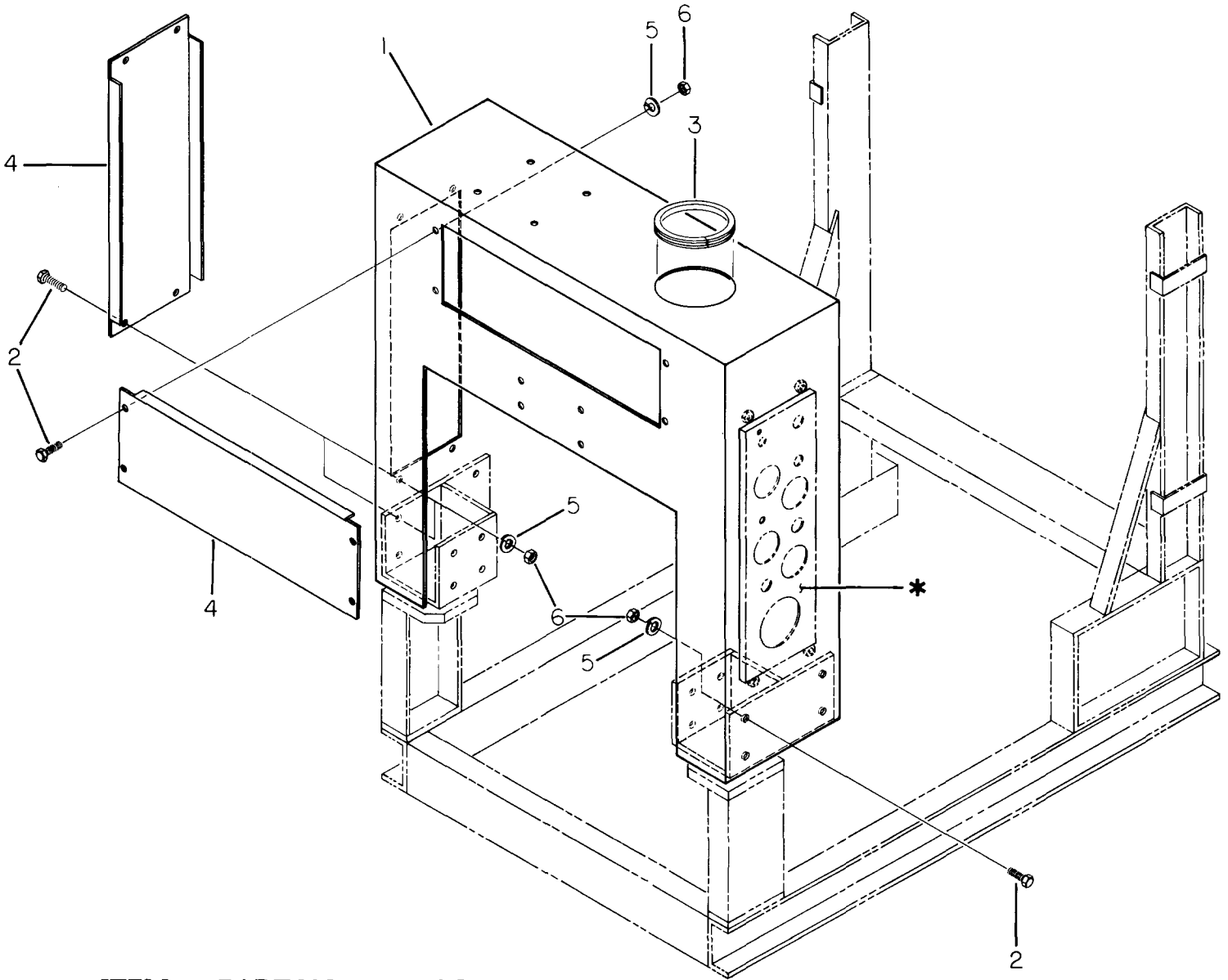

ITEM	PART NO.	DESCRIPTION .....	QTY
—	10271010	Enclosure kit (includes 1 thru 6) .....	1
1	10230019	Rear OPU panel .....	1
2	X22136	Screw, 5/16-18 x 1 .....	16
3	10270028-093	Edge Liner - 9 3/8 long .....	1
4	10230027	Rear panel cover plate .....	2
5	X00202B	Washer, lock, 5/16 .....	16
6	X01801E	Nut, 5/16-18 .....	16

\* Standard location for Instrumentation Panel & Mounting Kit — see sheets 30 or 36.  
 Alternate locations by interchanging with item #4 on rear & left side.

# Enclosure Kit — TM/TMD CPU

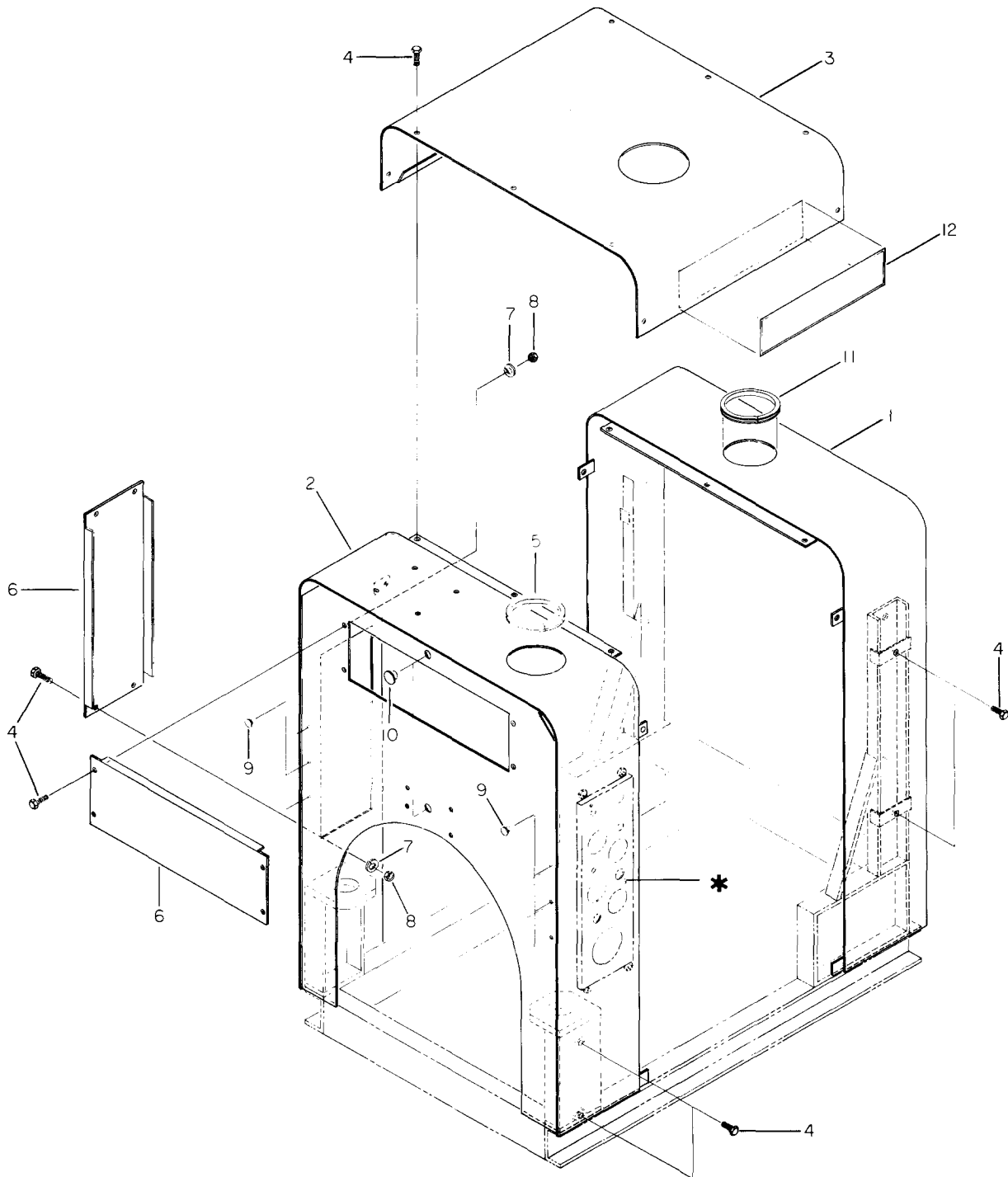

\* Standard location for Instrumentation Panel & Mounting Kit — see sheets 30 or 36.  
Alternate locations by interchanging with item #6 on rear & left side.

## Enclosure Kit — TM/TMD CPU

ITEM	PART NO.	DESCRIPTION	QTY	
			TM/TMD20 (1)	TM/TMD27 (2)
—	10271007	Enclosure kit - TM/TMD20 includes items in column (1)	1	
—	10271002	Enclosure kit - TM/TMD27 includes items in column (2)		1
1	10230018	Front panel assembly	1	1
2	10230017	Rear panel assembly	1	1
3	10270005	Hood TM/TMD20	1	
	10270011	Hood TM/TMD27		1
4	X22136	Screw, 5/16-18 x 1" long	26	26
5	10270028-093	Edge liner - 9 3/8" long	1	1
6	10230027	Rear panel cover plate	2	2
7	X00202B	Washer, lock, 5/16"	8	8
8	X01801E	Nut, hex, 5/16-18	8	8
9	10270020	Plug - 3/8 BPF - Caplug	6	6
10	10270023	Plug - 3/4 BPF - Caplug	2	2
11	10270028-160	Edge liner - 16" long	1	1
12	10250001	Continental power unit decal	2	2





## Fuel Tank Kit

### TM20/TM27, TMD20/TMD27

ITEM	PART NO.	DESCRIPTION	QTY	
			TM20/27 (1)	TMD20/27 (2)
—	10211008	Fuel tank kit - TM20/TM27 includes items in column (1)	1	
—	10211009	Fuel tank kit - TMD20/TMD27 includes items in column (2)		1
1	10210018	Fuel tank - TM/TMD	1	1
2	10210019	Fuel tank spacer	2	2
3	10210020	Fuel tank spacer insulator	2	2
4	X03159	Screw, 5/16 - 18 x 1" long	6	6
5	X14219	Washer, flat, 5/16	6	6
6	X00202B	Washer, lock, 5/16"	6	6
7	X01801E	Nut, 5/16 x 18	6	6
8	LK37	Hose clamp	4	4
9	LL205-30	Fuel hose, 30" (split & install 8" from fuel pump)	1	
	10210027-360	Fuel hose, 36" (supply)		1
10	RG41	Fuel cut-off valve	1	1
11	10210027-220	Fuel hose, 22" (return)		1
12	RF1438	1/8 NPT straight connector for 1/4 hose	1	
	10210026	1/8 NPT straight connector for 5/16 hose		2
13	50210004	Fuel filter	1	
14	10210025	3/8 inverted flare to 5/16 hose		1
15	10210022	1/8 NPT plug - flush type	1	
16	10270029	Grommet - Caplug GRO - 3/4 - UL	1	2

# Notes

# Full Instrumentation Panel and Mounting Kit

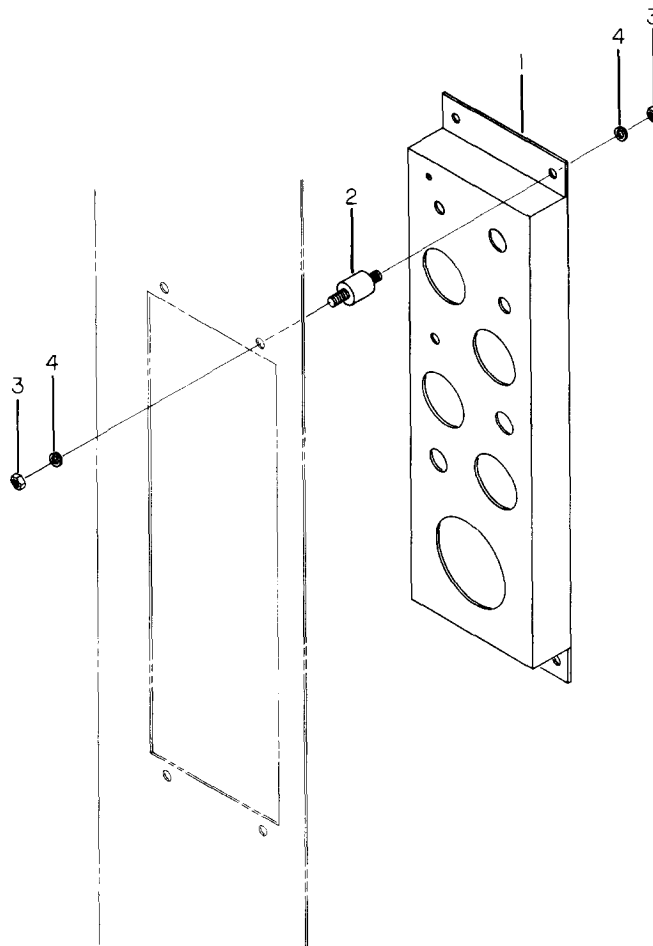

ITEM	PART NO.	DESCRIPTION	QTY
—	10231012	Full instrumentation panel and mounting kit (includes 1 thru 4).....	1
1	10230013	Large instrumentation panel .....	1
2	10100020	Instrument panel mount.....	4
3	X01801E	Nut, 5/16-18 .....	8
4	X00202B	Washer, lock, 5/16" .....	8

# Full Instrumentation Kit -TM

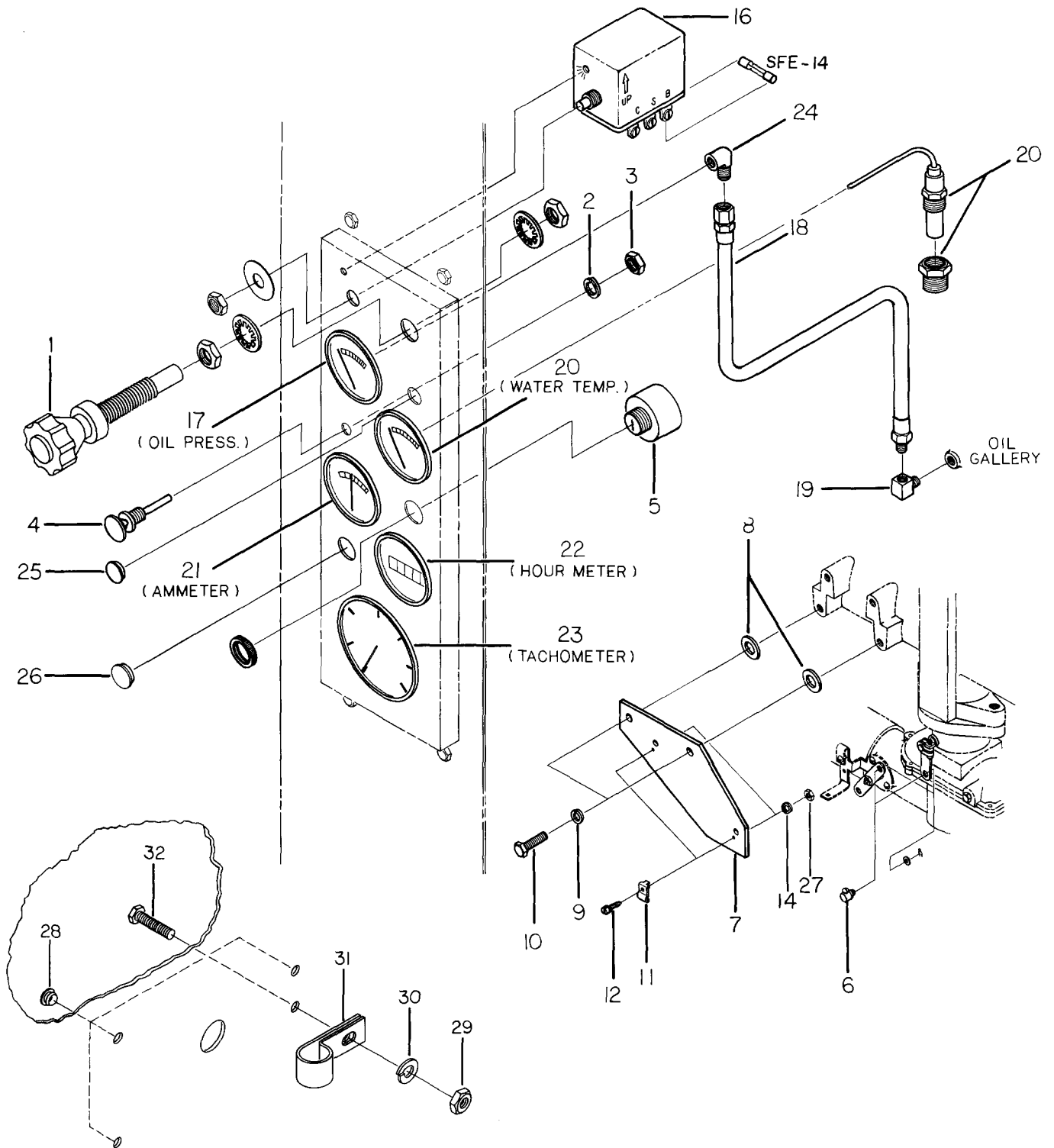

Viewed from inside rear panel

## Full Instrumentation Kit - TM

ITEM	PART NO.	DESCRIPTION	QTY
—	10231005	Full instrumentation kit - TM (includes 1 thru 32) .....	1
1	X07745480	Throttle control .....	1
—	X072523480	Throttle control (see SPB # 93-434)	
2	X00297	Washer, lock 3/8.....	1
3	X18180	Nut, 3/8-24 .....	1
4	C143F00309	Choke .....	1
5	10180001	Ignition switch .....	1
6	TM27F00204	Swivel assembly .....	1
7	TM27F00305	Throttle cable bracket.....	1
8	X14186	Washer, flat, 3/8 .....	2
9	XM37002	Washer, lock, M8 .....	2
10	XM32028	Screw, M8 x 1.25 x 20 mm long .....	2
11	CK20F00215	Cable wire clamp .....	2
12	CKF00285	Throttle cable bracket bolt.....	2
13	10120046	Wiring harness (see page 8) .....	1
14	X14543	Washer, lock # 6 .....	2
15	10120056	Wiring diagram (see page 7) .....	1
16	TD427M00204	Magnetic switch .....	1
17	F162M00356	Oil pressure switch.....	1
18	RM1049E	Tubing assembly, 19" long .....	1
19	RF996	90° street elbow .....	1
20	F162M00358	Water temperature switch.....	1
21	10230005	Ammeter .....	1
22	10230022	Hour meter .....	1
23	10120044	Alternator driven tachometer .....	1
24	RF1421	Female elbow, 1/4 tubing .....	1
25	10270022	Plug - 5/8 BPF - Caplug .....	1
26	10270038	Plug - 13/16 BP - Caplug.....	1
27	PD152	Nut, hex, # 6-32 .....	2
28	10270019	* Plug-1/4, BPF - Caplug .....	3
29	PD77	* Nut, hex, 1/4 - 20 .....	1
30	PE3	* Washer, lock, 1/4.....	1
31	10120092	* Clip wiring harness .....	1
32	XD7	* Screw, 1/4 -20 x 1" LG. hex head .....	1
—	10231012	Instrumentation & mounting kit (see page 30) .....	1

\* Components for Kit # 10231042

# Full Instrumentation Kit - TMD

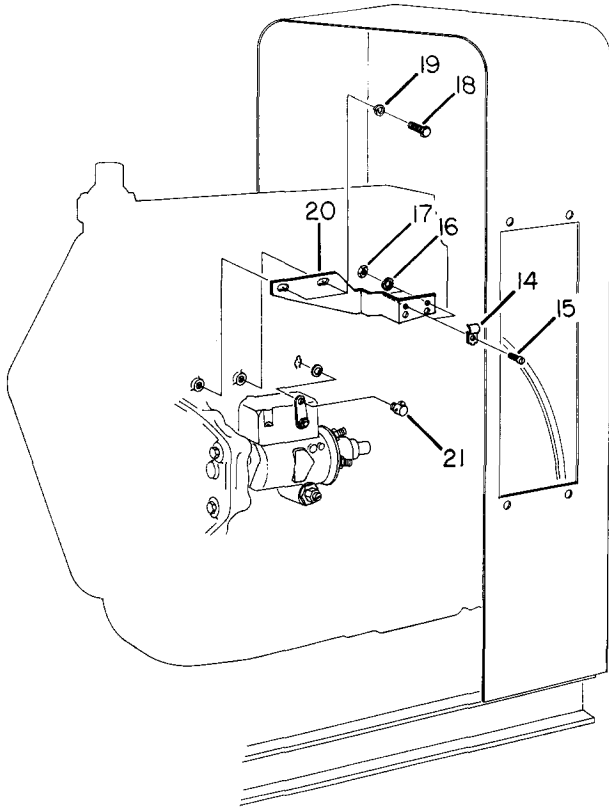
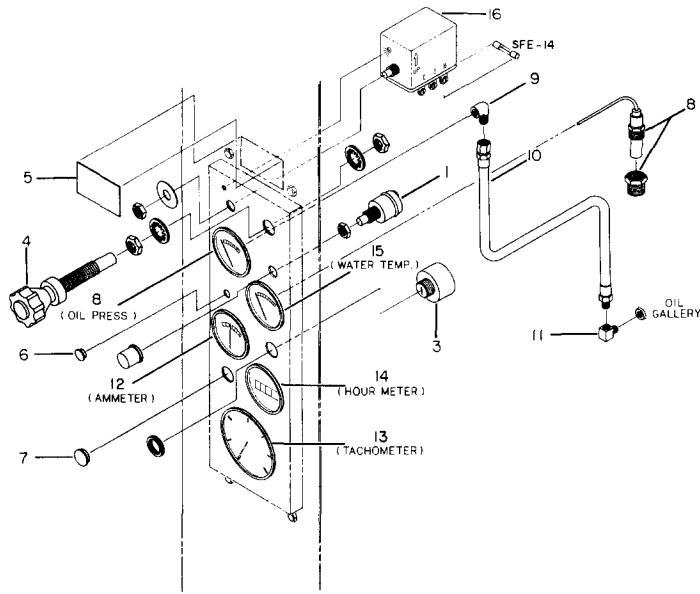

**Stanadyne Fuel System**  
 10231010 - TMD20  
 10231041 - TMD27

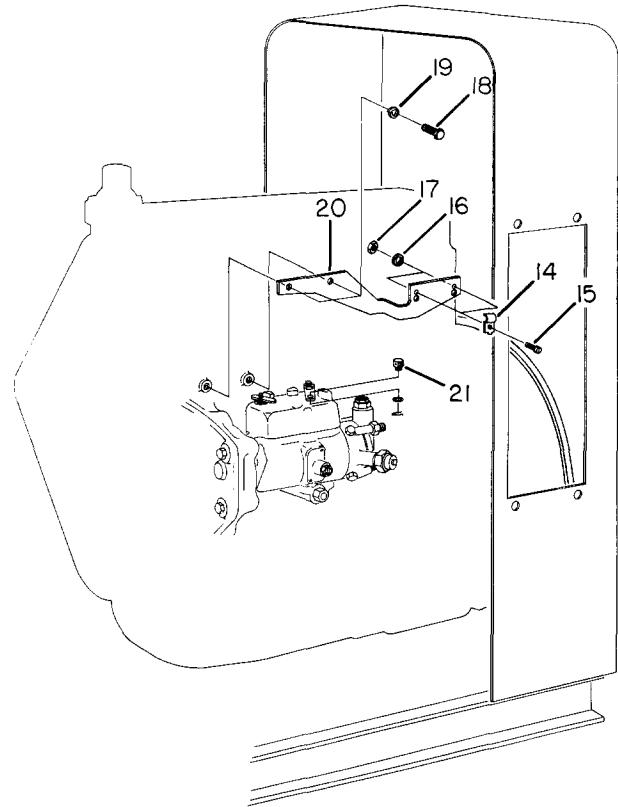

**CAV Fuel System**  
 10231007 - TMD27

## Full Instrumentation Kit - TMD

ITEM	PART NO.	DESCRIPTION	QTY		
			TMD27 CAV (1)	TMD20 STAN (2)	TMD27 STAN (3)
—	10231007	Instrumentation kit - TMD CAV includes items in column (1)	1		
—	10231010	Instrumentation kit - TMD20 Stanadyne includes items in column (2)		1	
—	10231041	Instrumentation kit -TMD27 Stanadyne includes items in column (3).			1
1	TMD27M00200	Glow plug push switch	1	1	1
2	10271009	Fuse block and solenoid kit (see page 41)	1	1	1
3	10180001	Ignition switch	1	1	1
4	X07745480	Throttle control	1	1	1
5	TMD27M00203	Glow time label	1	1	1
6	10270020	Plug - 3/8 BPF - Caplug	1	1	1
7	10270038	Plug - 13/16 BP - Caplug	1	1	1
8	F162M00356	Oil pressure gauge	1	1	1
9	RF1421	Female elbow, 1/4 tubing	1	1	1
10	RM1049E	Tubing assembly	1	1	1
11	RF996	90° Street elbow	1	1	1
12	10230005	Ammeter	1	1	1
13	10120044	Tachometer	1	1	1
14	10230022	Hourmeter	1	1	1
15	F162M00358	Water temperature switch	1	1	1
16	TD427M00204	Magnetic switch	1	1	1
17	CK20F00215	Cable wire clamp	2	2	2
18	CKF00285	Throttle cable bracket bolt	2	2	2
19	PD152	Nut, hex, #6-32	2	2	2
20	X14543	Washer, lock #6	2	2	2
21	XM32028	Screw, M8 x 1.25 x 20 mm long	2	2	2
22	XM37002	Washer, lock, M8	2	2	2
23	TMD27F00513	Throttle cable bracket	1		
	TMD20F00405	Throttle cable bracket		1	
	10140013	Throttle cable bracket			1
24	TM27F00204	Swivel assembly	1		
	10210021	Swivel assembly		1	1
25	10120048	Wiring harness (see page 10)	1	1	1
26	10120054	Wiring diagram (see page 9)	1	1	1
—	10231012	Instrumentation & mounting kit (see page 30)	1	1	1

# Notes



# Optional Instrumentation Panel and Mounting Kit

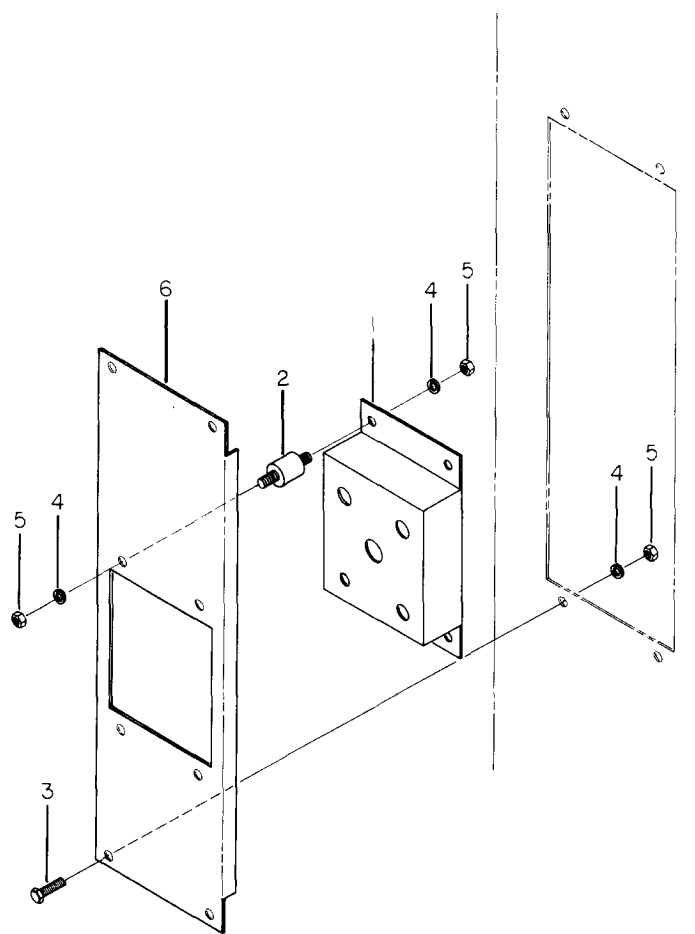

ITEM	PART NO.	DESCRIPTION	QTY
—	10231011	Panel and mounting kit (includes 1 thru 6) .....	1
1	10230014	Small instrumentation panel .....	1
2	10100020	Instrument panel mount .....	4
3	X22136	Screw, 5/16-18 x 1" long .....	4
4	X00202B	Washer, lock, 5/16" .....	12
5	X01801E	Nut, hex 5/16 -18 .....	12
6	10230015	Panel .....	1

# Optional Instrumentation Kit - TM

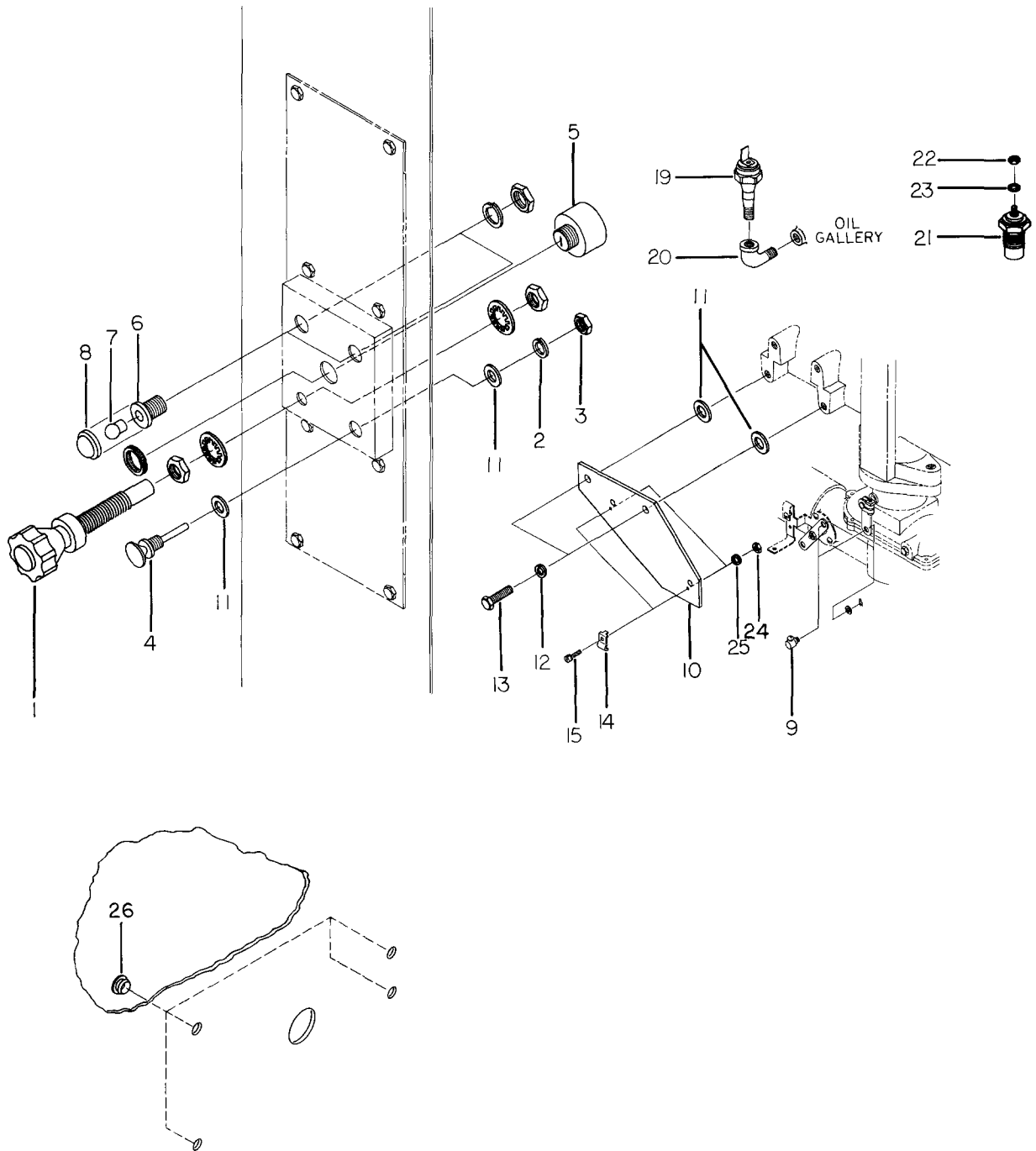

Viewed from inside rear panel.

## Optional Instrumentation Kit - TM

ITEM	PART NO.	DESCRIPTION	QTY
—	10231004	Instrumentation kit - TM optional (includes 1 thru 26) .....	1
1	X07745480	Throttle control .....	1
	X072523480	Throttle control (see SPB # 93-434)	
2	X00297	Washer, lock, 3/8" .....	1
3	X18180	Nut, 3/8-24 .....	1
4	C143F00309	Choke .....	1
5	10180001	Ignition switch .....	1
6	TM27M00203	Bulb holder .....	2
7	TM27M00205	12 V Bulb .....	2
8	TM27M00204	Red lens .....	2
9	TM27F00204	Swivel assembly .....	1
10	TM27F00305	Throttle cable bracket .....	1
11	X14186	Spacer, 3/16 .....	4
12	XM37002	Washer, lock, M8 .....	2
13	XM32028	Screw, M8 x 1.25 x 20 mm long .....	2
14	CK20F00215	Cable wire clamp .....	2
15	CKF00285	Throttle cable bracket bolt .....	2
16	10120045	Wiring harness (see page 12) .....	1
17	X07847	Tie wrap (not shown) .....	8
18	10120055	Wiring diagram (see page 11) .....	1
19	TM27M00303	Oil pressure switch .....	1
20	X12332	90° Elbow, 1/8 NPT .....	1
21	TM27M00302	Water temperature switch .....	1
22	13XX01896	Nut, hex, #10 - 32 .....	1
23	15XX00200B	Washer, lock, 3/16 .....	1
24	PD152	Nut, hex, #6 - 32 .....	2
25	X14543	Washer, lock, #6 .....	2
26	10270019	Plug - 1/4 BPF .....	4
—	10231011	Instrumentaion panel and mounting kit (see page 36) .....	1

# Optional Instrumentation Kit - TMD

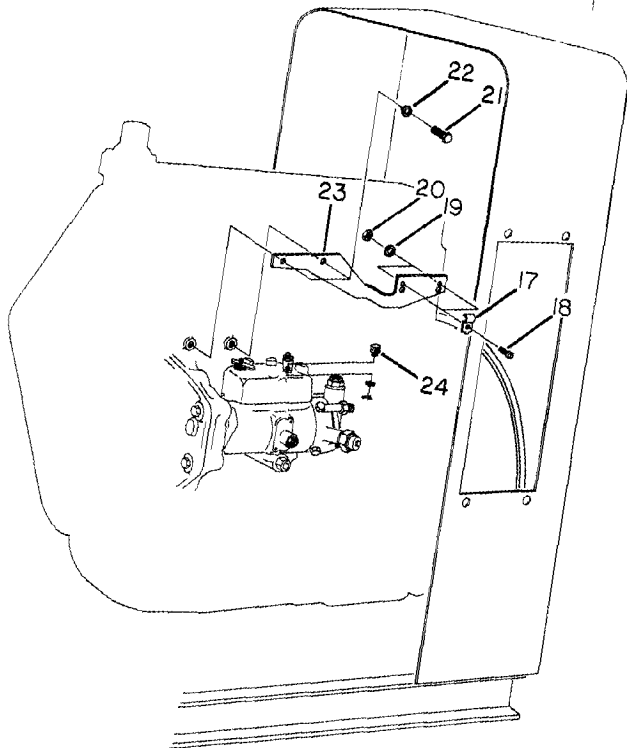
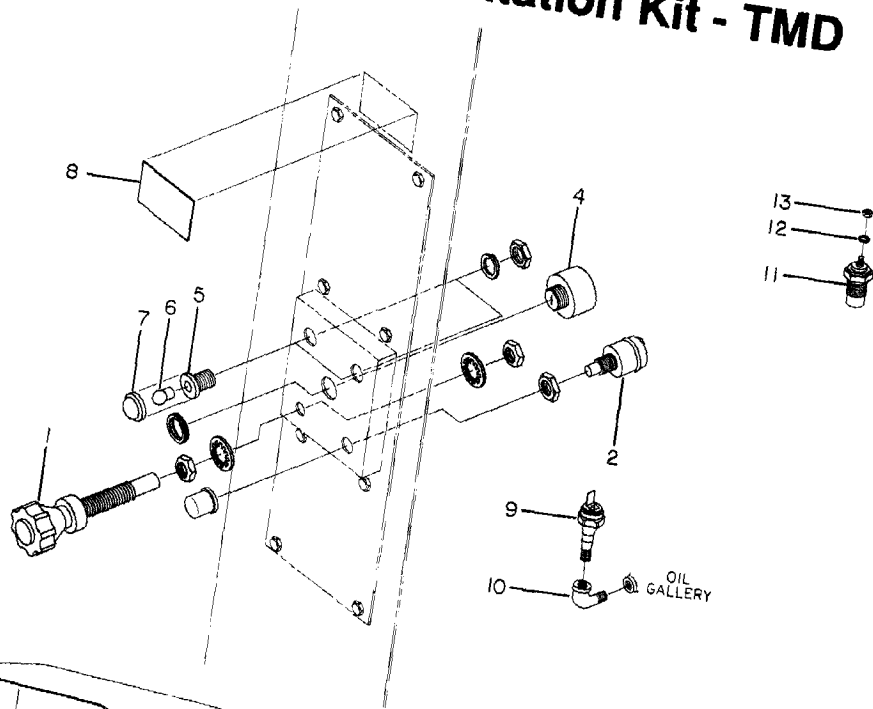

CAV Fuel System  
10231006 TMD27

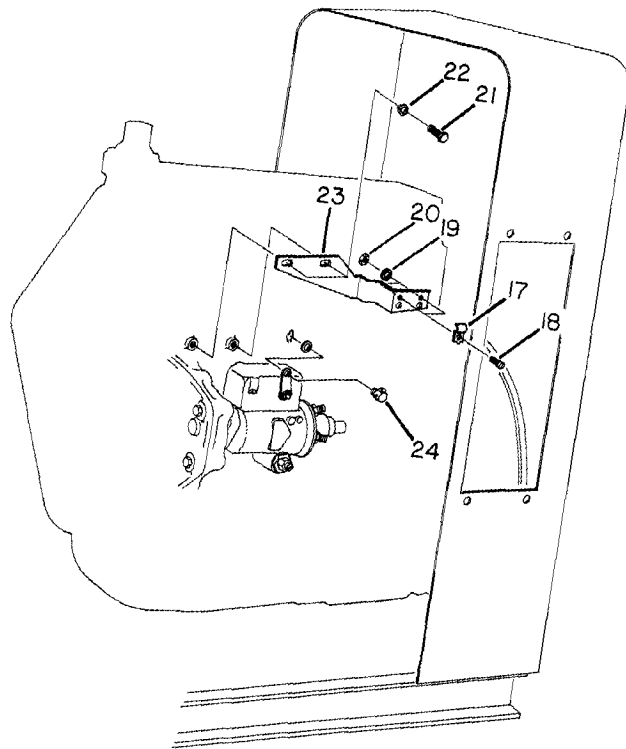

Stanadyne Fuel System  
10231009 TMD20  
10231040 TMD27

## Optional Instrumentation Kit - TMD

ITEM	PART NO.	DESCRIPTION	QTY		
			TMD27 CAV (1)	TMD20 STAN (2)	TMD27 STAN (3)
—	10231006	Instrumentation kit - TMD CAV Optional includes items in column (1)	1		
—	10231009	Instrumentation kit- TMD20 Optional includes items in column (2)		1	
—	10231040	Instrumentation kit - TMD27 Optional includes items in column (3)			1
1	X07745480	Throttle control	1	1	1
2	TMD27M00200	Glow plug push switch	1	1	1
3	10271009	Fuse block and solenoid kit (see page 41)	1	1	1
4	10180001	Ignition switch	1	1	1
5	TM27M00203	Bulb holder	2	2	2
6	TM27M00205	12 V Bulb	2	2	2
7	TM27M00204	Red lens	2	2	2
8	TMD27M00203	Glow time label	1	1	1
9	TM27M00303	Oil pressure switch	1	1	1
10	X12332	90° Elbow, 1/8 NPT	1	1	1
11	TM27M00302	Water temperature switch	1	1	1
12	15XX00200B	Washer, lock, 3/16	1	1	1
13	13XX001896	Nut, hex, #10-32	1	1	1
14	CK20F00215	Cable wire clamp	2	2	2
15	CKF00285	Throttle cable bracket bolt	2	2	2
16	X14543	Washer, lock, #6	2	2	2
17	PD152	Nut, hex, #6-32	2	2	2
18	XM32028	Screw, M8 x 1.25 x 20 mm long	2	2	2
19	XM37002	Washer, lock, M8	2	2	2
20	TMD27F00513	Throttle cable bracket	1		
	TMD20F00405	Throttle cable bracket		1	
	10140013	Throttle cable bracket			1
21	TM27F00204	Swivel assembly	1		
	10210021	Swivel assembly		1	1
22	10120047	Wiring harness (see page 14)	1	1	1
23	X07847	Tie wrap (not shown)	8	8	8
24	10120053	Wiring diagram (see page 13)	1	1	2
—	10231011	Panel and mounting kit (see page 36)	1	1	1

## Fuse Block and Solenoid Kit - TMD

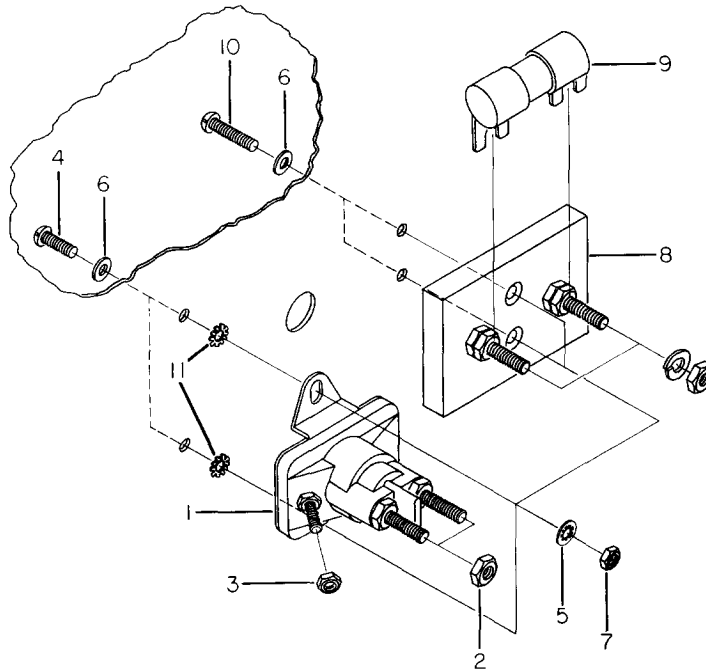

ITEM	PART NO.	DESCRIPTION	QTY
—	10271009	Fuse block and solenoid kit - TMD (includes 1 thru 11) .....	1
1	TMD27M00305	Solenoid contactor .....	1
2	13XX01800C	Nut, hex, 1/4-20 .....	2
3	13XX01896	Nut, hex, #10-32 CP .....	1
4	X03784	Screw, #10-24 x 1/2 .....	2
5	X00200B	Washer, lock, #10 .....	4
6	X14139	Washer, flat, #10 .....	4
7	X18077	Nut, #10-24 .....	4
8	TMD27M00202	Fuse block .....	1
9	TMD27M00201	80 Amp fuse .....	1
10	X22138	Screw, #10-24 x 3/4 .....	2
11	X14599	Washer, ext. tooth, #10 .....	2

NOTE: Items viewed from inside the following panels:  
 10230017 Rear Panel CPU  
 10230019 Rear Panel OPU

## Air Cleaner Kit - TM/TMD

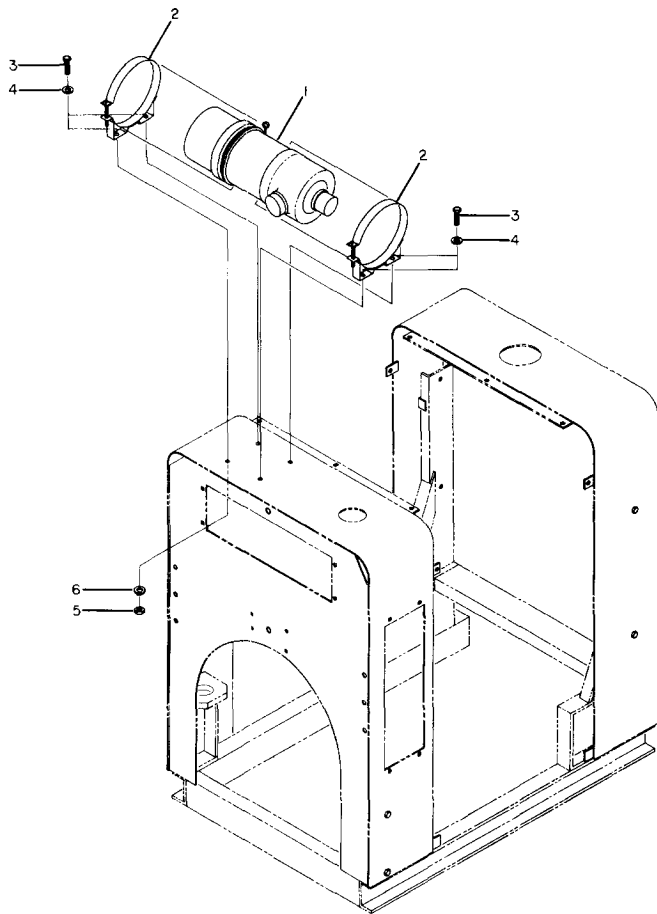

## Optional Air Cleaner Locations

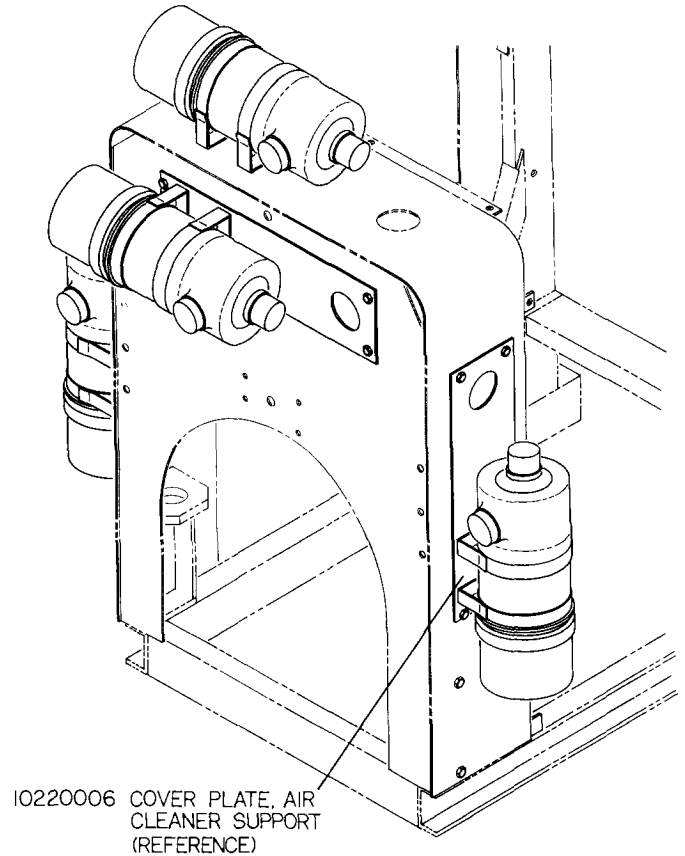

ITEM	PART NO.	DESCRIPTION	QTY
—	TM4T00110	Air cleaner kit - TM/TMD (includes 1 thru 6) .....	1
1	* F245F00300	Air cleaner .....	1
2	F400F00256	Air cleaner support band .....	2
3	X03593	Screw, 3/8 - 16 x 3/4 long .....	4
4	X14323	Washer, flat, 3/8 .....	4
5	X18412	Nut, 3/8-16 .....	4
6	X00203	Washer, lock, 3/8.....	4

\* F245F00200 Element

# Air Cleaner Hose Kits - TMD

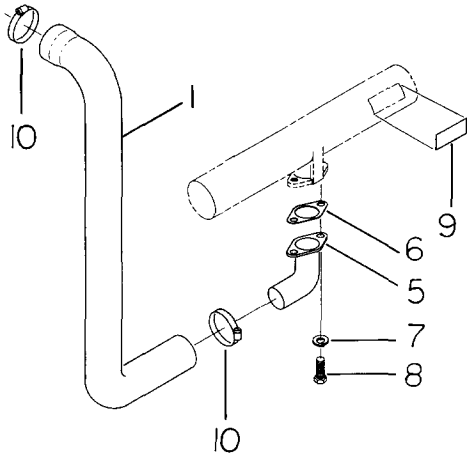

10221005 - TMD Top Mount

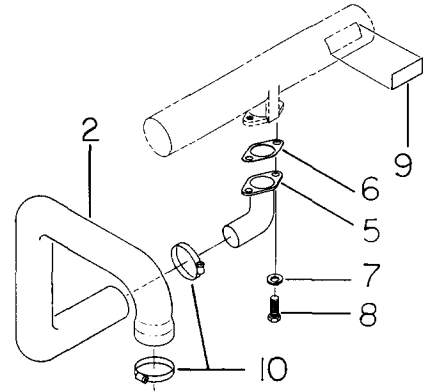

10221011 - TMD R.H. Mount

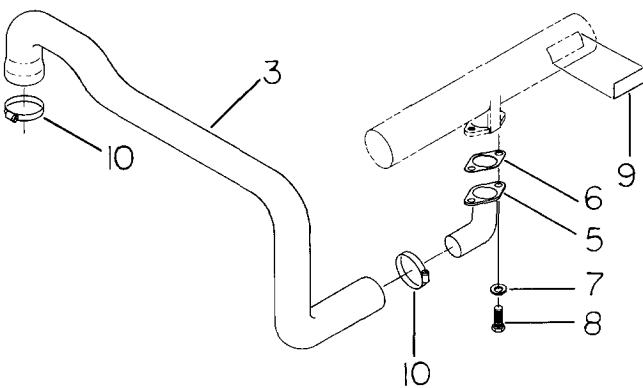

10221010 - TMD L.H. Mount

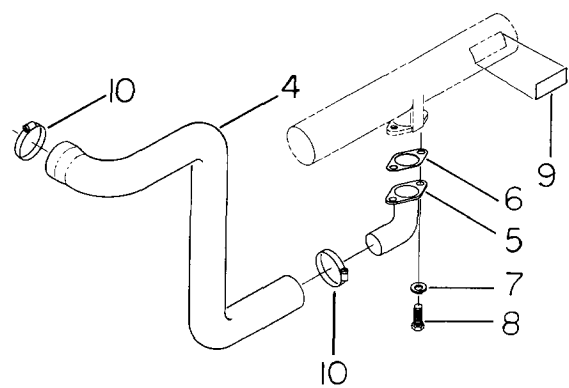

10221012 - TMD Back Mount



## Air Cleaner Hose Kit - TMD

ITEM PART NO.	DESCRIPTION	QTY			
		TOP (1)	RH (2)	LH (3)	REAR (4)
— 10221005	Air cleaner hose kit -TMD top mount includes items in column (1)	1			
— 10221011	Air cleaner hose kit - TMD right side mount includes items in column (2)		1		
— 10221010	Air cleaner hose kit - TMD left side mount includes items in column (3)			1	
— 10221012	Air cleaner hose kit - TMD rear mount includes items in column (4)				1
1 10060004	Hose - air intake - molded (top)	1			
2 10060003	Hose - air intake - molded (RH)		1		
3 10060005	Hose - air intake - molded (LH)			1	
4 10060006	Hose - air intake - molded (rear)				1
5 TMD27F00408	Elbow, air inlet	1	1	1	1
6 TMD27F00222	Gasket - elbow	1	1	1	1
7 XM37012	Washer - int. tooth, M8	2	2	2	2
8 XM32037	Screw, M8 x 1.25 x 25 mm long	2	2	2	2
9 X06233	Starting fluid warning decal	1	1	1	1
10 X02388	Hose clamp, 2-1/2"	2	2	2	2
11 10270026	Plug - 3BPF - Caplug (not shown)		1	1	1
12 10270020	Plug - 3/8 BPF - Caplug (not shown)		4	4	4
13 10220006	Air cleaner support cover plate (not shown)		1	1	1
14 10270028	Edge liner - 9-3/8 (not shown)	1	1	1	1
15 10290053	TM/TMD Instruction sheet - molded hose modification	1	1	1	1

NOTE: Reference Service Parts Bulletin 93-444 for all previous air cleaner hose arrangements.

# Air Cleaner Hose Kit - TM

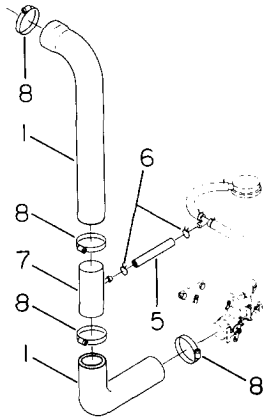

10221007 - TM Top Mount

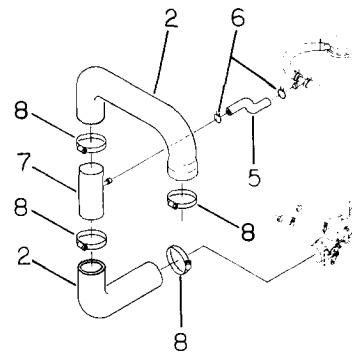

10221008 - TM R. H. Mount

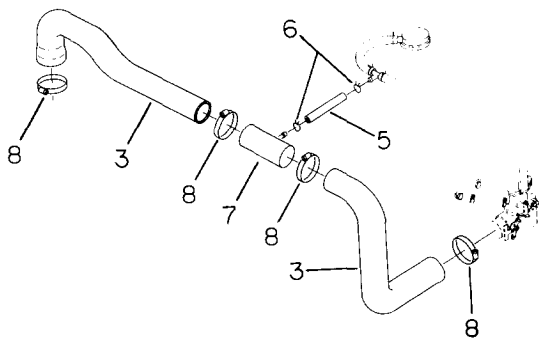

10221006 - TM L.H. Mount

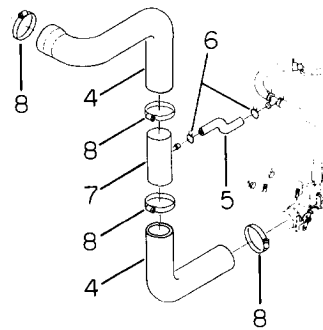

10221009 - TM Back Mount

## Air Cleaner Hose Kit -TM

ITEM	PART NO.	DESCRIPTION	QTY			
			TOP (1)	RH (2)	LH (3)	REAR (4)
—	10221007	Air cleaner hose kit - TM top mount includes items in column (1)	1			
—	10221008	Air cleaner hose kit - TM right side mount includes items in column (2)		1		
—	10221006	Air cleaner hose kit - TM left side mount includes items in column (3)			1	
—	10221009	Air cleaner hose kit - TM rear mount includes items in column (4)				1
1	10060004	Hose - air intake - molded (top)	1			
2	10060003	Hose - air intake - molded (RH)		1		
3	10060005	Hose - air intake - molded (LH)			1	
4	10060006	Hose - air intake - molded (rear)				1
5	X08253120	Hose, 1/2 I.D. x 12" long	1	1	1	1
6	X02751	Hose clamp, 3/4" PCU	2	2	2	2
7	10220019	Air inlet tube assembly, 2" O.D., 4-1/4" LG.	1	1	1	1
8	X02388	Hose clamp, 2-1/2	4	4	4	4
9	10270026	Plug - 3 BPF - Caplug (not shown)		1	1	1
10	10270020	Plug - 3/8 BPF - Caplug (not shown)		4	4	4
11	10220006	Air cleaner support cover plate (not shown)	1	1	1	
12	10270028	Edge liner - 9-3/8" (not shown)	1	1	1	1
13	10290053	TM/TMD Instruction sheet - molded hose modification	1	1	1	1

NOTE: Reference Service Parts Bulletin 93-444 for all previous air cleaner hose arrangements.

# Battery Box Kit

## TM/TMD Power Unit Kit

### Part No. 10121004

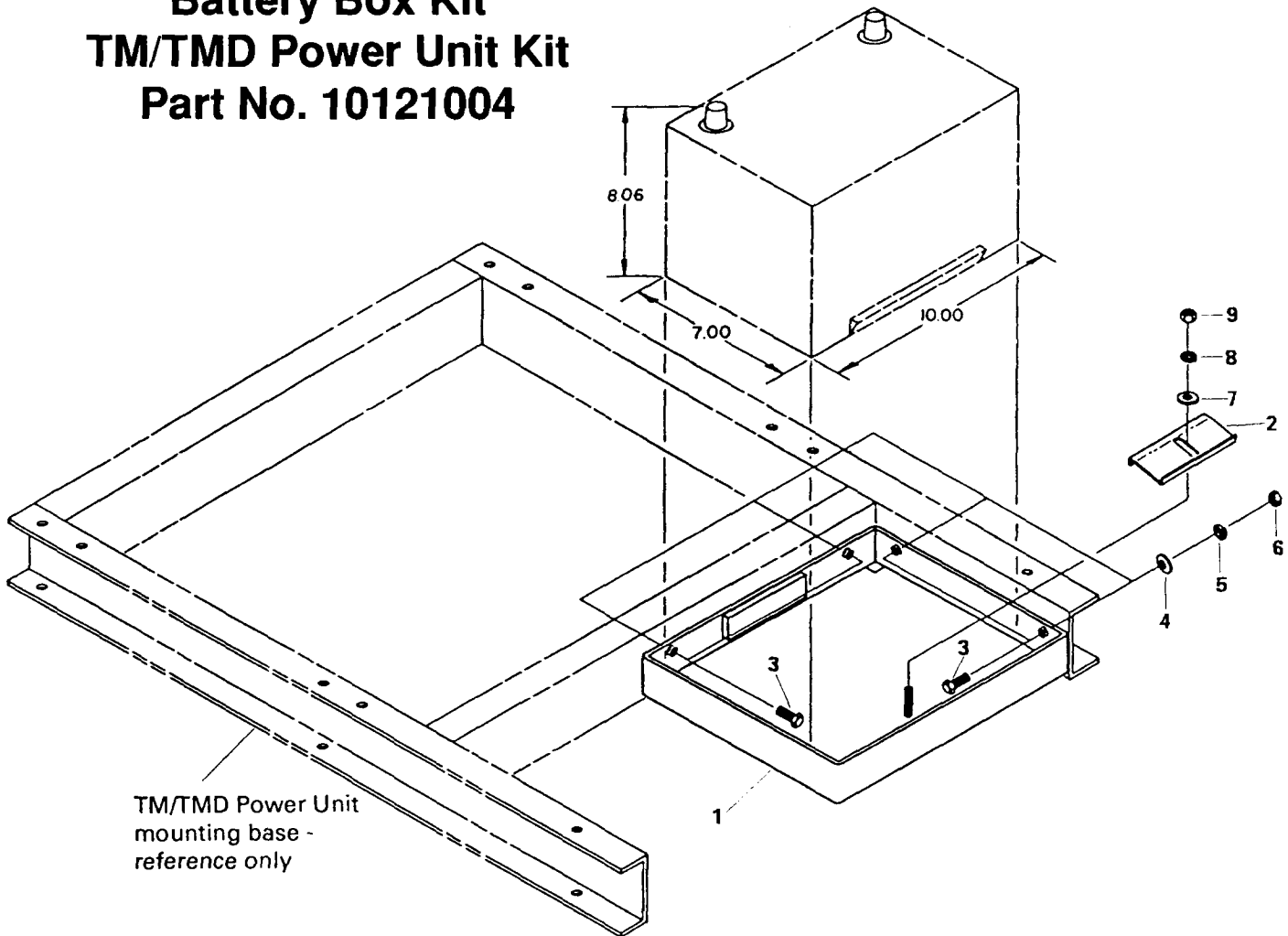

ITEM	COMPONENT	QTY	DESCRIPTION
1	10120051	1	Battery Box
2	10120052	1	Hold Down Clip, Battery Box
3	X03942	4	Bolt, hex 3/8" - 16 x 1
4	X14472	4	Washer, flat 3/8"
5	X00203	4	Washer, lock 3/8"
6	X01802G	4	Nut, hex 3/8" - 16
7	X14219	1	Washer, flat 5/16"
8	X00202B	1	Washer, lock 5/16"
9	X01801E	1	Nut, hex 5/16" - 18

- NOTES:
- Battery size not to exceed limits shown (10.00 inches length, 7.00 inches width, 8.06 inches height, measured over posts). Larger battery cannot be installed.
  - Battery recommendations are as follows:

ENGINE	CCA
TMD	625
TM	450

- To install battery in closed power unit, front sheet metal panel must be removed.

**P  
O  
W  
E  
R  
  
U  
N  
I  
T  
S**

**SERVICE AND PARTS**  
**Available from your Authorized**  
**WISCONSIN**  
**Service Center**



**California Proposition 65**

The engine exhaust from this product contains chemicals known to the State of California to cause cancer, birth defects or other reproductive harm.



**WISCONSIN**  
**MOTORS, LLC**

**SALES OFFICE:**

2020 Fletcher Creek Drive, Memphis, Tennessee 38133

Phone: (901) 371-0353 or Toll Free (800) 932-2858

[www.wisconsinmotors.com](http://www.wisconsinmotors.com)